

The Wireless World

THE
PRACTICAL RADIO
JOURNAL
26th Year of Publication

No. 901.

FRIDAY, DECEMBER 4TH, 1936.

VOL. XXXIX. No. 23.

Proprietors: ILIFFE & SONS LTD.

Editor:
HUGH S. POCOCK.

Editorial,
Advertising and Publishing Offices:
DORSET HOUSE, STAMFORD STREET,
LONDON, S.E.1.

Telephone: Waterloo 3333 (50 lines).
Telegrams: "Ethaworld, Sedist, London."

COVENTRY: Hertford Street.

Telegrams: "Autocar, Coventry." Telephone: 5270 Coventry.

BIRMINGHAM:

Guildhall Buildings, Navigation Street, 2.
Telegrams: "Autopress, Birmingham." Telephone: 2971 Midland (4 lines).

MANCHESTER: 260, Deansgate, 3.

Telegrams: "Iliffe, Manchester." Telephone: Blackfriars 4412 (4 lines).

GLASGOW: 26B, Renfield Street, C.2.

Telegrams: "Iliffe, Glasgow." Telephone: Central 4857.

PUBLISHED WEEKLY. ENTERED AS SECOND
CLASS MATTER AT NEW YORK, N.Y.

Subscription Rates:

Home, £1 1s. 8d.; Canada, £1 1s. 8d.; other
countries, £1 3s. 10d. per annum.

*As many of the circuits and apparatus described in these
pages are covered by patents, readers are advised, before
making use of them, to satisfy themselves that they would
not be infringing patents.*

CONTENTS

	Page
Editorial Comment	587
Rejecting Whistles	588
Current Topics	592
Sound Recording, Part II	593
Listeners' Guide for the Week	596
Unbiased	598
New Apparatus Reviewed	599
Broadcast Brevities	600
Random Radiations	601
Anson "Commodore" Radio- gramophone	602
Going Down: A "Run" on the Ultra-short Waves	606
Recent Inventions	608

EDITORIAL COMMENT

Wavelength Allocation

New Influence on Receiver Design

THE allocation of wavelengths for wireless transmitters is a matter to which much thought has been devoted in the past. There are so many problems encountered that a perfect solution to them all is really out of the question, particularly as the matter is complicated by international questions.

Although the international aspect cannot be entirely ignored even in America, it is of much less importance in that country than in Europe, and it is thus more easily possible to settle problems on their technical aspects. The American Radio Manufacturers' Association has recently been considering this question of wavelength allocation, with particular reference to broadcasting. In its recommendations to the Federal Communication Commission the Association lays particular emphasis upon receiver performance, and, in order to show the importance of this, has amassed a large amount of data on 1935 and 1936 models of broadcast receivers.

The average performance of sets of these two years shows surprisingly little difference, and the Association points out that with the present station spacing of 10 kc/s only, it is unlikely that there will be any marked improvement in fidelity or selectivity in the next few years. It points out that the present popularity of the superheterodyne is likely to continue, for both technically and economically it offers big advantages over the straight set. The superheterodyne, however, suffers from liability to certain special forms of interference, among which prominence is given to that caused by a

transmitter working on a frequency close to the intermediate frequency. Interference may also be found from stations working on multiples of the intermediate frequency, or when the frequency separation of stations is equal to the intermediate frequency.

While these forms of interference can undoubtedly be greatly reduced by suitable design of the receivers, the result is naturally an increase of cost, and most manufacturers prefer to try to avoid the interference by a suitable choice of the intermediate frequency. With the present allocation of stations, however, a particular intermediate frequency will only permit freedom from interference in one part of the country, and different frequencies must be used in others. Hence the present lack of uniformity in the frequencies employed in the receivers of to-day.

How Choice of Wavelengths Can Help

It is suggested that this difficulty could be got over by a more suitable allocation of station wavelengths and, in particular, by leaving a clear channel to which the IF amplifier could be tuned. One intermediate frequency for all receivers could then be standardised and, as well as reducing the possibility of interference, would prove an economy in receiver production.

This suggestion opens up an interesting possibility and one which we may hope to find given serious consideration by those responsible for European wavelengths. In any case, there is no doubt that the only hope of appreciable improvement in the future lies in closer co-operation between those whose business it is to settle wavelength questions and those who are responsible for receiver design.

Rejecting Whistles

A NEW TYPE OF BALANCE FILTER

By P. K. TURNER, M.I.E.E.

(Hartley-Turner Radio, Ltd.)

NOW that there is an increasing tendency to demand a certain amount of "top" in radio reproduction, the question of a whistle-filter is getting more and more important.

Admittedly, so long as one sticks to RF or IF amplifiers based on the band-pass filter idea, whistles form only part of the interference, since side-band splash is very prominent; but even so most people find the continuous whistle much more offensive than "monkey-chatter." And where high-selectivity circuits and tone-correction are used, side-band splash is so reduced that such a set has quite a surprising power of getting a pleasurable programme through interference, provided an efficient whistle-filter is fitted.

The first attempts at whistle-filters seem to have been simply low-pass filters arranged to cut out the whistle and all higher frequencies. In order to be effective on all likely whistles they were mostly designed to cut at 5 kc/s or thereabouts, and so definitely ruined the quality; we will not consider them further.

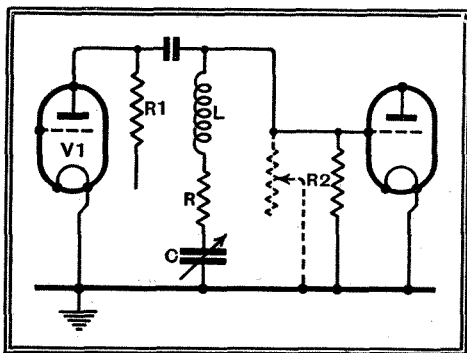

Fig. 1.—An acceptor filter, which acts more or less as a short-circuit across the amplifier at the resonant frequency.

The only "filters" which can pretend to be effective at reasonable cost are those embodying tuned circuits, which are adjusted by the user to cut out one particular frequency with the minimum of interference with others.

The most obvious design of this nature consists simply of an acceptor circuit

across an amplifier coupling or a rejector in series with a coupling load; both these can be quite effective, and are therefore worthy of a little consideration.

The acceptor filter is shown in Fig. 1, and it is quite easy to find what are its requirements. Calculation shows that its performance depends on two things. First, the losses in coil and condenser must be small—i.e., the resistance R (which represents these losses) must be low compared with the reactance of the coil or condenser at the tuned frequency, which latter we will refer to as X_0 . Secondly, X_0 must have the right relationship with the other impedances in the circuit. It is easily shown that the important characteristic of the rest of the circuit is the resistance R' given by putting R_1 , R_2 , and the anode impedance of V_1 , all in parallel.

At the resonant frequency, the total impedance of the filter is R , and if it is

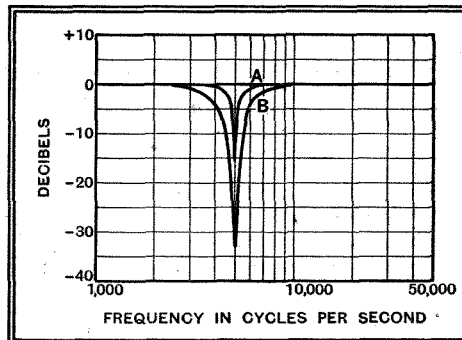

Fig. 2.—Typical characteristics, under different conditions, of an acceptor filter.

to do its job of being effectively a short-circuit across the amplifier, R must be much less than R' . At far-off frequencies the impedance of the filter is the reactance of L or C , and this must be large compared with R' if the loss is then to be negligible.

If L is too small and C too large for the rest of the circuit, the "cut" will be good, but there will be too much loss at other frequencies; if L is too large and C too small, the dip in the response curve will be nice and narrow, but not deep enough.

But in practice the values of L and C are almost fixed, for as C is to be a variable condenser it cannot exceed 0.0005 mfd. if we are to use what is easily obtainable; and in order to cover the right range of frequencies this means that L must be about 1.5-2 H. Hence, in practice, the

resistance R' must be adjusted to suit these values. These are two very simple rules which govern the design: to keep them simple I have left out sundry corrections.

(1) The "cut," i.e., the ratio of output with filter to output without, at the tuned frequency, is simply R/R' .

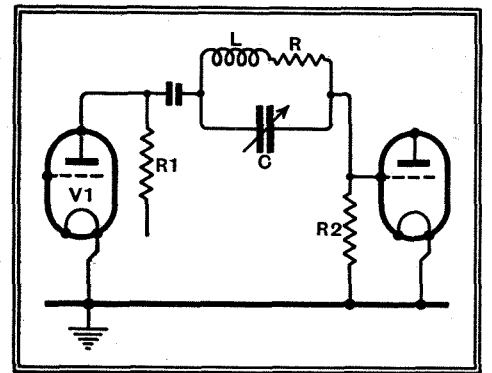

Fig. 3.—A rejector filter; compare with the acceptor circuit of Fig. 1.

(2) The cycles off tune at which there is about 30%, or 3 db., loss is $\frac{0.08R'}{L}$ or $\frac{2R'}{25L}$

As an example, if we have a 10,000-ohm valve, a 20,000-ohm load, and a 0.1-megohm grid leak, then

$$\frac{I}{R'} = \frac{I}{10,000} \left(\frac{1}{2} + \frac{1}{10} \right) = \frac{1.6}{10,000}, \text{ or } R' = 6,250 \text{ ohms.}$$

If now we have a 2-henry coil with loss

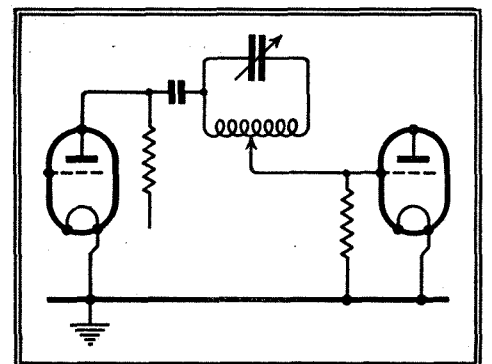

Fig. 4.—An alternative arrangement of the rejector filter for use in a transformer-coupled stage; it is referred to in Appendix I.

resistance (at the tuned frequency) of 1,000 ohms, then

Rejecting Whistles—

- (1) the "cut" is $R/R' = 1,000/6,250 = 0.16$, or approximately 16 db.
- (2) there is 3 db. loss at $2R'/25L$ or $\frac{12,500}{50}$ or 250 c/s each side of the tuned point.

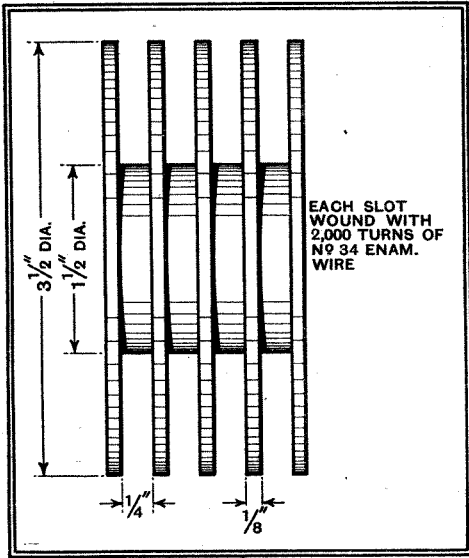

Fig. 5.—Design for an air-cored inductance coil. Each slot of the former is wound with 2,000 turns of No. 34 enamelled wire.

The curve will be more or less like A of Fig. 2: the cut is fairly sharp but not deep.

Now suppose that we use the same coil, but after a pentode valve with an impedance of 0.5 megohm, and with a load of 50,000 ohms; we have

$$\frac{I}{R'} = \frac{I}{10,000} \left(\frac{1}{50} + \frac{1}{5} + \frac{1}{10} \right) = \frac{0.32}{10,000}, \text{ or } R' = 31,250 \text{ ohms.}$$

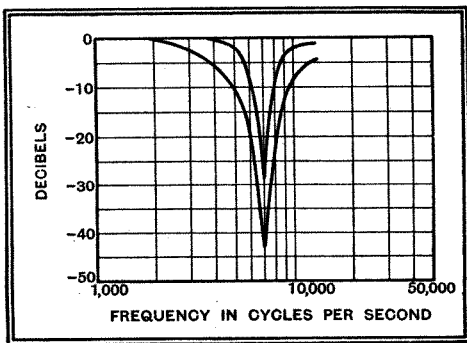

Fig. 6.—Curves of a filter wired to the circuit of Fig. 3, with the coil of Fig. 5.

The cut is now $\frac{1,000}{31,250} = 0.032$, or approximately 30 db., and there is 3 db. loss at $\frac{62,500}{50} = 1,250$ c/s each side.

The curve is like B of Fig. 2; fairly deep, but rather wide. Note that the loss resistance R only affects the "cut." A better coil will give a deeper cut without widening it. On the other hand an increase of R' makes the dip in the curve both deeper and wider.

Another important point to be noticed is the effect of changing the tuning point.

As the frequency goes up, R will almost certainly increase, so that the cut will be less deep. Also, as the width of the dip is constant in cycles, it will be comparatively less as the frequency goes up. Summarised, the cut is both deeper and wider as the tuned frequency is lower.

In order to correct this, and at the same time give a control of the band width of the dip, it is best to make R' adjustable by putting a variable shunt across the grid leak, as shown dotted in Fig. 1.

The Rejector Circuit

The rejector filter is shown in Fig. 3, and in its actual behaviour is very much like the acceptor filter. In exactly the same way, at any given frequency the depth of cut is controlled by the loss resistance R, while the width is governed by the resistance of the rest of the circuit. But there is one important difference: with the rejector the cut is deeper and proportionately wider as the frequency goes up—just opposite to the acceptor.

There is another difference: the important circuit resistance is not in this case

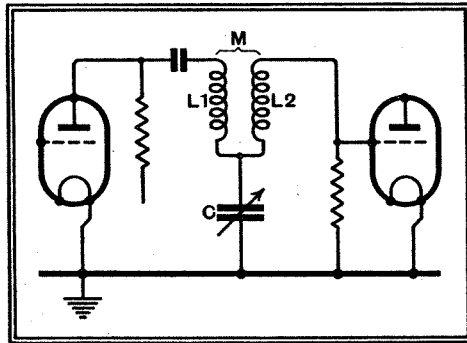

Fig. 7.—The Campbell Sifter, in which coil losses are unimportant.

that of valve, anode load, and grid leak all in parallel. It is that of valve and anode load in parallel, added to that of the leak. The rules for depth and width of cut are not so simple in this case, and I give them in Appendix I.

Both the acceptor and rejector circuits can be made quite reasonably efficient, and two types of the rejector have actually been on the market for two years or so. The main difficulty is to keep the coil losses low enough to get a reasonably sharp dip. A coil of 1.5 or 2 henrys which shall be really efficient at 10 kc/s or thereabouts is not at all easy to design. For really first-class results an air-cored coil is essential, and Fig. 5 shows the design of one which has been found good and not too expensive. Used with an air-condenser in the circuit of Fig. 3, it produced the curves of Fig. 6, which are for two different values of shunt across the grid leak.

The biggest difficulty is the bulk and large stray field of the coil; for a big stray field also means a big capacity for picking up other stray fields. In a mains-operated set it is practically impossible to get the coil out of hum fields, and no screen less than about a 9in. cube may be used for fear of losses. The only solution is careful

placing and orientation of the coil: a silent point can usually be found.

Recently a smaller coil with a dust core has been produced. This is much better as regards stray field, and is cheaper and less bulky, but it is not so efficient.

At first sight the Campbell Sifter seems a much more promising arrangement, for coil losses do not matter. The circuit is shown in Fig. 7, and its behaviour is in theory almost exactly the same as that of the acceptor circuit of Fig. 1, except that M, the mutual inductance between L1 and L2, replaces L of the acceptor. Since the losses in L1 and L2 do not enter into M, the filter should be exceedingly good. Actually I have found it disappointing,

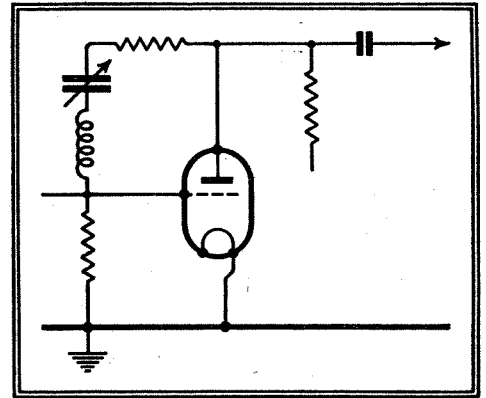

Fig. 8.—Baggally's Retroactive Filter.

the difficulty, as usual, being in the coil. The coil losses, it is true, do not enter into M, but it still does not follow that the voltage induced in L2 will be exactly 90° behind the current in L1. If an iron core of any kind is used, hysteresis and eddy current effects prevent this; in a close-coupled air-cooled coil, capacity from L1 to L2 gives trouble; in either case the cut will be quite a poor one. With a rather loose-coupled air-cored coil the cut is good, but the output will not come back to near normal at frequencies above resonance. The difficulty with the coil is increased by the fact that each half of the coil must have the same inductance as the whole coil of the acceptor, so that twice the total turns are needed.

Better Coils Wanted

As far as my own experience has gone the success of the Campbell Sifter depends on a new coil design; and the necessary time for this is better spent on improved circuits.

Baggally's Retroactive Filter is a highly ingenious arrangement described by Baggally in *The Wireless Engineer* for December, 1935. The circuit of Fig. 8 is used. It has the effect that when the impedance of the acceptor circuit is low negative feed-back is put on the valve, so that the output is reduced. The cut obtained is very sharp, as can be seen from the curve of Fig. 8a, reproduced from his article. Personally, however, I do not find the arrangement convenient.

There are two reasons for this. First, the amplifier has to be to a considerable

Rejecting Whistles—

extent designed round the filter; one cannot just drop the circuit into any set. Second, if one uses a coil with fairly high losses, it is necessary either to use a valve of low conductivity or to cut down its goodness in some way. The reason for this is given in Appendix II.

The Balance-Filter is a new introduction, and my enthusiasm for it must perhaps be discounted a little because it is my

Fig. 8 (a).—Curve of the filter shown in Fig. 8. (Reproduced from "The Wireless Engineer.")

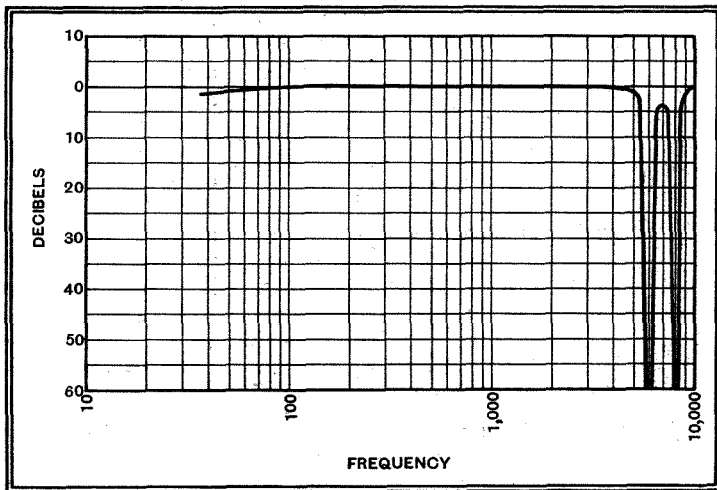

own baby. The circuit is shown in Fig. 9. As will be seen, the output has two components; first, the voltage across C_1 , which is controlled by the values of C_1 and R_1 ; and second, the voltage in L_4 , which (for a given M) is controlled by C_2 . It can easily be proved that these may always be made equal and opposite (giving zero output) by adjusting the values of two of the components, and this holds even if all components are imperfect, including M . Of course, *very* bad components may spoil the sharpness of cut and give losses at all frequencies; but the cut still remains deep.

Circuit Calculations

The actual frequency at which the dip occurs is calculated as for a circuit of capacity C_2 and inductance L_2 plus M : if the transformer L_2 - L_4 is a one-to-one and closely coupled, this means approximately an effective inductance of $2L_2$. The rule for frequency is, approximately,

$$f^2 = \frac{25,000}{(M + L_2)C_2}, \text{ with } M \text{ and } L_2 \text{ in henrys, } C_2 \text{ in mfd.}$$

A second condition which I call the "balance condition" has to be fulfilled to get zero output; it is

$$\frac{R_1}{R} = \left(1 + \frac{L_2}{M}\right) \frac{C_2}{C_1}$$

Both the above are for perfect components. The effect of the losses on the frequency is small, but they modify the "balance" condition in a manner to be discussed later.

Reverting to the balance condition already given, it should be stated that losses in L_2 and C_2 (represented by R) are taken account of. It is only losses in C_1 and M that have been neglected.

Looking at the condition in detail, usually L_2 and M will not change with frequency, but, of course, C_2 will, being the main tuning adjustment. If now we gang C_2 and C_1 together, then C_2/C_1 is constant, being 1. So that if R does not change with frequency R_1 must not either;

in fact, operation of the two-gang condenser is all that is required.

But in practice R *does* alter. It almost always increases as the frequency goes up.

So that after setting the condenser to cut down a whistle, it is usually necessary to adjust R_1 to get rid of it completely; the higher the frequency the larger R_1 . Even if R were constant, there are still the effects of losses in C_1 and M , which were neglected above; it is easily shown that they have the same general effect.

It would appear, then, that two adjustments are necessary. In fact, in the experimental models of the balance filter a whole series is necessary. First the condensers are set to best "cut." Then R_1 is adjusted, with a considerable improvement. But this change of R_1 means that a slight readjustment of the gang condenser gives a still deeper cut, but in turn calls for a final adjustment of R_1 .

In the type now in use I have adopted a rather neat method of getting over this. As stated above, it is usually—as far as my own experience goes, *invariably*—the case that R increases as frequency goes up, so that R_1 must be increased to maintain the balance condition. But the same result is obtained if C_2/C_1 is decreased as frequency goes up. But as frequency goes up, both C_2 and C_1 have to be decreased; what is required is that C_1 should not be cut down as much as C_2 , though they are both on the same shaft.

But this is easy. All we have to do is to put a small fixed condenser across C_1 . For example, if both condensers are of 0.0005 mfd. max. value, and we put 0.0001 mfd. across C_1 , then when C_2 is at 500, $C_1 = 600$ m-mfds., and $C_2/C_1 = 5/6$. But for $C_2 = 100$, $C_1 = 200$ m-mfds., and $C_2/C_1 = 1/2$.

By choosing the right value of fixed "trimmer," the needed value of R_1 may always be made the same at two different frequencies—say 8 and 10 kc/s, for example. If R_1 is then fixed, the loss of "cut" at 7, 9 and 11 kc/s (due to R_1 not being just right) will often be negligible. But if it is thought worth while a "padding" condenser can be put in series with C_1 before putting the "trimmer" across it. The balance can then be made quite correct at *three* frequencies, and the residual

error at other frequencies will always be negligible.

Before giving some results of tests on Balance Filters I want to put down a few words about methods of test, which are not so simple as might appear.

First of all, the measurements should be made on a constant input basis and in a practical amplifier, to reproduce as closely as possible the conditions of use. This means that the output will vary from a fraction of a volt to 200 V or so at the anodes of the power valves, and so one needs a multi-range output meter of fixed input impedance on all ranges.

Whistle, Hum and Background Noise

With an amplifier set to give, say, 200 V output, and the filter giving maximum "cut," there will probably be found a minimum reading of *at least* 10 volts of combined whistle, hum and background noise. So I introduce between output valves and meter (i.e., after all the amplification) a high-pass filter cutting at about 2,000 c/s, to cut out the hum and most of its harmonics. This will reduce the minimum reading to 1 volt or so.

Next, since the input must be fairly big to get a readable output through the filter, we must face the possibility of harmonics being generated. It must be remembered that even a 1 per cent. harmonic will give much more output than the filtered fundamental. So I put in a low pass filter also, set to cut at 8,000 cycles when testing on 7,000, and so on.

There is still left the background noise. Since some of this comes from the source, it is not sound to turn down its output by its volume control. The only check (the source being a beat oscillator) is to turn it down to zero beat. This leaves the background noise unchanged, and one can compare the output at zero beat with that at the tuned frequency of the filter, and so find what is the output in the latter case.

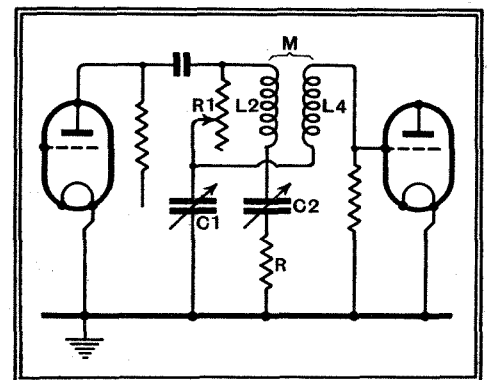

Fig. 9.—The Balance-Filter, as devised by the author.

It must be remembered that with the whistle on, our reading is the resultant of whistle and background noise, the latter being of no particular frequency. We must, therefore, add the *squares* of the two to get the resultant, i.e., the voltage needed is found thus:

$$\text{Total voltage with source at filter frequency} = \sqrt{V_f^2 + V_b^2}$$

Rejecting Whistles—

Voltage with source at zero beat, which is background noise = V_B .

True output at filter frequency =

$$\sqrt{V_F^2 - V_B^2}$$

Note that if $V_F^2 = 1V$ and $V_B = 0.95 V$, we have $V_F^2 = 1$, $V_B^2 = 0.9$; hence (True volts)² = 0.1, and true volts = about 0.3. In other words, if the true voltage is less than about one-third the total, it is not measurable with any accuracy. Conversely, if the total voltage is more than three times the background, the correction is negligible, and the total can be taken as the true output voltage.

Lastly, as the various additions to the circuit will affect the response of the amplifier, it is advisable to make each measurement by switching in and out the filter under test and plotting the actual drop in output thus found.

The filter used for the following tests had two small bakelite-dielectric condensers ganged up, and a smallish dust-coiled coil measuring 1 1/2 in. diam. and 1 1/2 in. long. This was wound in three sections, two being L2 and one L4. No attempt at screening or shielding was made, and all parts of curves below 40 db. drop are shown dotted, as readings were uncertain. It is believed that in most cases the "cut" was 50 to 60 db.

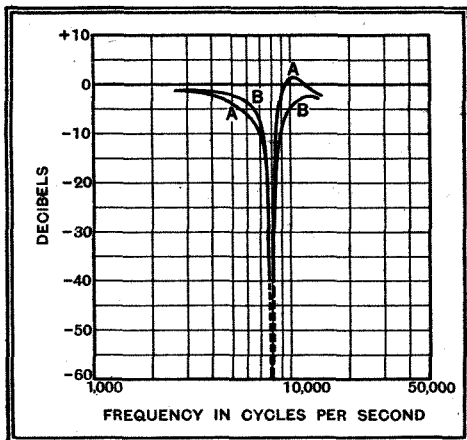

Fig. 10.—The effect of output load on the balance filter.

Fig. 10 shows the effect of output load. For curve A the filter was working into a 0.25-megohm grid leak; for curve B into a loaded AF transformer which put a load of about 10,000 ohms (besides inductance and capacity) on the filter. It will be seen that there is surprisingly little difference in performance.

Fig. 11 shows the effect of input load, and it is obvious that this is much more important. To emphasise the differences, these curves were taken with the filter tuned to a low frequency (7 kc/s) and working into 0.25 megohm as output load. For curve A the total input load was 2,500 ohms; for B 10,000 ohms, and for C 20,000 ohms. Curve A of Fig. 10 was for about 6,000 ohms, the input there being a 9,000-ohm valve with 15,000-ohm coupling resistor.

Lastly, Fig. 12 shows the effect of changing the filtered frequency, the conditions in each case being about 6,000 ohms

input and transformer output load as for curve B of Fig. 10.

Two conclusions may be drawn from these curves. First, the filter always gives an exceptionally deep "cut." In most of the cases shown the actual output voltage at the critical frequency was adjusted to 100 without filter and the output with filter varied from 0.1 to 0.5 volt; in no case was the resulting signal audible above the background.

Secondly, there is no necessity for critical impedance-matching. Using the coils and condensers described, output impedance matters little so long as it exceeds, say, 10,000 ohms, and it need not be a pure resistance; input resistance should not exceed 10,000 ohms.

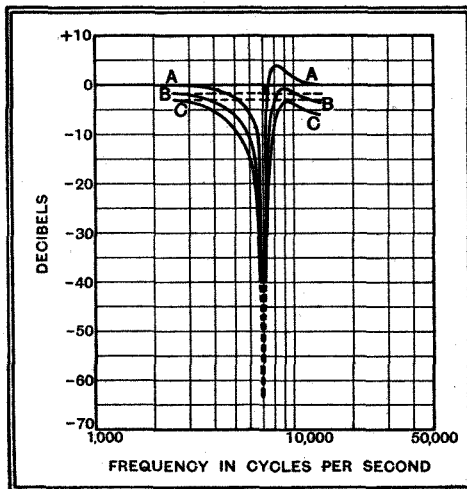

Fig. 11.—Showing the more drastic effect of input load variations (compare with Fig. 10).

It is, however, desirable to use a coil designed for the circuit¹. Any old coil of the right inductance will give a deep cut; but if its losses are very high or the coupling between its two parts is too weak, the rest of the curve may be unsatisfactory.

APPENDIX I.

With R_1 and R_2 as in Fig. 3,

$$R' = \frac{R_a R_1}{R_a + R_1} + R_2$$

where R_a is the anode impedance of V.

Call X_0 the reactance of the coil at the tuned frequency f_0 ($X_0 = 2\pi f_0 L$)

Then, approximately,

$$(1) \text{ Depth of cut} = \frac{RR'}{X_0^2} = \frac{RR'}{4\pi^2 f_0^2 L^2}$$

(2) There is 3 db. loss at p cycles off tune, where

$$\rho = \frac{\pi^2 L}{R'}, \text{ or } \rho = \frac{X_0}{2R'}$$

In practice, the cut is controlled by shunting the grid-leak, as for the acceptor filter, to give the cut required at the moment.

There is, however, another method of control of the rejector which makes it often more convenient to use. This is shown in Fig. 4. In effect, it makes the coil into a transformer; the tuned frequency and losses are practically unaffected, but the matching to the rest of the circuit is controlled by the tap switch. When the rejector is used in a resistance coupled circuit, as in Fig. 3, the circuit resistance is usually too high, and a variable shunt across the grid leak is the best control. But for use in a transformer-coupled stage the tap switch of Fig. 4 is usually preferable.

¹ It is understood that separate parts and complete filters to the author's design will shortly be on sale.—Ed.

APPENDIX II.

Bagally shows that for minimum output we have the following condition, where R is the loss resistance of the acceptor:

$$R = R'_a / \mu'$$

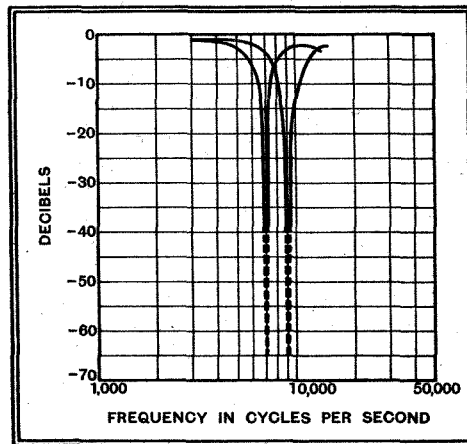

Fig. 12.—Effect of changing the filtered frequency.

R'_a and μ' being the effective anode impedance and magnification of the valve. Since the effective conductivity of the valve is μ'/R'_a we have $RG' = 1000$, with G' in mA/volt.

Hence for a good modern valve of $G = 2$, or thereabouts, R cannot exceed 500 ohms for balance, which means a very good coil. If R is higher than this, G' must be reduced, say by artificially raising R_a by means of resistance added between the valve anode and the rest of the circuit. But since the effective mag. of the whole stage depends on G' , one has to lower this, which is undesirable and may get one into other difficulties.

CLUB NEWS

The Ilford and District Radio Society

This old-established radio society has now entered upon its sixteenth year and is making a special feature of television and ultra-short-wave work. Those interested are welcomed at the weekly meetings, which are held at 8 p.m. on Thursdays at St. Alban's Church Room, Albert Road, Ilford. On Thursday next (December 10th) a demonstration of a new receiver will be given by Mr. H. T. Stott, A.M.I.R.E., of Bulgin's. Full details concerning the society can be obtained from the Hon. Secretary, at 44, Trelawney Road, Barkingside, Ilford.

The Croydon Radio Society

An interesting lantern lecture on cathode-ray tubes was recently given by Mr. A. F. Hollins, of the Mullard Wireless Service Co. A large number of questions, including television problems, were dealt with. On Tuesday, December 15th, at 8 p.m., Mr. H. G. Salter will conclude the first half of the winter session with another of his ever-popular musical programmes. The Hon. Secretary, Mr. E. L. Cumbers, 14, Campden Road, South Croydon, will be pleased to give full details of the society's activities to enquirers.

The Radio, Physical and Television Society

Several interesting lectures have been given recently, including those on the cathode-ray oscillograph by Dr. C. G. Lemon, short-wave receivers by Mr. J. G. Hobbs, A.M.I.R.E. (G2QG), and bacteriological methods by Lt.-Col. C. G. Coppinger, R.A.M.C. Readers are cordially invited to attend the meetings, which are held at 8 p.m. on Fridays at 72a, North End Road, West Kensington, W.14. Full details of future lectures may be had from the Hon. Secretary, at 48, Fitzjames Avenue, W.14.

Current Topics

NEWS OF THE WEEK IN BRIEF REVIEW

A Noteworthy Anniversary

TEN years have passed by since the opening of the first Empire beam service. The first circuit linked England and Canada, the stations being Bodmin and Bridgwater at the home end and Yamachiche and Drummondville in Canada. This was followed by links to the other parts of the Empire. The success of the beam service led to the Imperial Wireless and Cable Conference and the subsequent amalgamation of these two services.

Arabian Nights Entertainments

THE Rome short-wave station which works on 25.40 metres now transmits certain of its news services in Arabic for the benefit of Italy's Moslem subjects. At these periods Arabian music is also transmitted. At present these special transmissions are given on four days a week only, but may be extended later.

Poland and Foreign Languages

IT is reported that the foreign language lessons which have been such a feature of certain Polish stations are to be discontinued on the ground that listeners are not profiting by them to the extent which was hoped. It is not stated whether or not the authorities have been influenced by the fact that increasing knowledge of foreign languages means increasing ability to imbibe foreign culture by listening to stations in neighbouring countries.

Europe Leads America

INTERESTING figures concerning the production of sets in the U.S.A. and Canada show that in the past six months of this year the former country produced 2½ million sets valued at 10 million sterling. Canadian production figures for the corresponding period are not yet available, but during the whole of 1935 Canada produced rather less than a quarter of a million sets valued at some 3½ million sterling.

In view of the above figures it is interesting to recall that a few years ago the United States possessed more broadcast receivers and listeners than the rest of the world put together. Nowadays, however, Europe is in front of America in the number of radio-equipped homes, the respective figures being estimated at 23 million for the U.S.A. and 25 million for Europe, excluding Russia.

An Ambitious Programme

CANADA'S new Broadcasting Commission is to make a thorough investigation into broadcasting conditions in the Dominion, and it is expected that several new stations will be built and others increased in power. It is a foregone conclusion that more attention is to be paid to broadcasting in French for the benefit of Canada's French-speaking population.

St. Bernard Up to Date

IT has been decided to equip all the refuges in the Italian part of the Alps with transmitting as well as receiving sets. Each life-saving expedition which sets out from the various refuges will be equipped with a portable transmitter and receiver so that it may keep in touch with its base. The refuge stations themselves will be able to communicate with special stations in the valleys in those cases where landline facilities are not available or have broken down through bad weather.

Jewish National Station?

IT is reported from Central Europe that plans are afoot to hire or build a transmitting station either in Switzerland or Czechoslovakia for the purpose of spreading Jewish culture. In some quarters it is stated that the main object is the counteracting of anti-Semitic propaganda from certain other European stations.

Wireless Amateurs' Trophy

WILLIAM S. PALEY, President of the Columbia Broadcasting System, has been so struck by the useful service which amateur transmitters have rendered to the community, such as during the disastrous floods in America early this year, that he has presented a trophy to be awarded annually to the amateur adjudged to have performed, by means of radio, the most meritorious service to the community during the preceding twelve months. Seven sculptors have been invited to submit suitable designs for the trophy, which will be in the permanent custody of the American Radio Relay League. The annual winner will have his name engraved on it and will also receive a small replica. The

Not many countries can boast of having a woman engineer on the staff of their broadcasting organisation. Here is Miss Klara Dalland in the control room of the Oslo station with Mr. Gythfeldt, the chief controlling engineer. Miss Dalland has just received an appointment at Norwegian broadcasting headquarters after serving for a period on the engineering staff of the Vadsø station.



Australian S.W. Transmission

DURING December, Sydney VK2ME will transmit on 9,590 kc/s (31.28 metres) every Sunday at the following times, all G.M.T.: 6 a.m.—8 a.m., 10 a.m.—4 p.m.

During the same period Melbourne VK3ME will transmit on 9,510 kc/s (31.55 metres) daily from Monday to Saturday from 9 a.m. to noon (G.M.T.).

I.E.E. Wireless Section

THERE will be a special meeting to-day (December 4th) at 7 p.m., when a paper, illustrated by demonstrations, will be read by Messrs. E. A. Speight, Ph.D., and O. W. Gill on the Post Office Speaking Clock.

The Radio Society of Great Britain

THE amateur movement in this country is in a remarkably healthy state if one can judge by the state of the finances of the Radio Society of Great Britain. Subscriptions which total £2,270 are £306 higher than last year. The balance of income over expenditure is £315.

An Engineers' Meeting

DISAPPOINTMENT with the alleged inactivity of the Institute of Radio Engineers has prompted Mr. C. W. Watson and other radio engineers, stated to be members of the Institute, to call a meeting to discuss the matter.

The meeting will take place at the Bedford Room, Hotel Russell, London, at 4 p.m. on December 7th.

Anyone wishing to attend should communicate with Mr. Watson at 22, St. John Maddermarket, Norwich.

The Institute of Radio Engineers referred to has no connection with the well-known American Institute of the same name.

first award, covering the year 1936, is expected to be made on March 15th next. Five famous men, headed by Admiral Grayson, have been selected to serve on the Board of Award.

Wireless Aids for Aircraft

ALL South African main airports are soon to be equipped with the latest type of wireless direction-finding and blind-landing apparatus. Details of the new equipment, which includes the Lorenz apparatus were discussed at a recent meeting of the South African Radio Relay League. The decision to equip the airports in this manner has been taken as a result of extensive experimental work that has been carried out at the Cape Town Airport.

British Sound Recording Association

THIS society has now been firmly established, and all who are interested in home or professional recording are invited to obtain full particulars from the Hon. Secretary at 7, Ernest Close, Beckenham, Kent. The subscription is purely nominal, and for those who live too far away to be able to attend the regular meetings a scheme of associate membership has been arranged. The Association meets at 44, Valley Road, Shortlands, Kent, at 8.30 p.m. on alternate Thursdays.

A full programme of lectures, demonstrations, and visits to places of interest covering all phases of sound recording is being arranged for the winter months. At recent meetings lectures have been given by well-known experts on sound recording on discs and sound recording on films.

Sound Recording

By S. R. EADE, A.M.I.E.E. (Of the Research Dept., B.T.H. Co., Rugby)

SOUND film of 16 mm. width is now well known and is capable of giving a satisfactory quality of reproduction. The reasons why it does not meet the home recording need can be summed up as expense and technical complexity of the apparatus and processing operation. It is, however, of great interest technically and is worth studying in some detail.

The major fields of usefulness of 16 mm. sound-on-film are educational, publicity, entertainment, where the expense of its full-sized brother is not justified, and, to a much less extent, home entertainment. This latter field will be much more fully developed when comprehensive libraries of films become generally available. Means for recording one's own talkies in this medium are at present, and likely to remain, outside the financial resources of the average amateur.

The great majority of 16 mm. sound films are made by optical reduction or re-recording processes from 35 mm. films. Two or three cameras are, however, available for direct sound and picture recording on 16 mm. One of these is of particular interest because the sound record is made by acoustic-photographic means without an intervening electrical link. The operator speaks directly into the camera, and so the range of sound pick-up is of course limited.

Any single-film system of this type

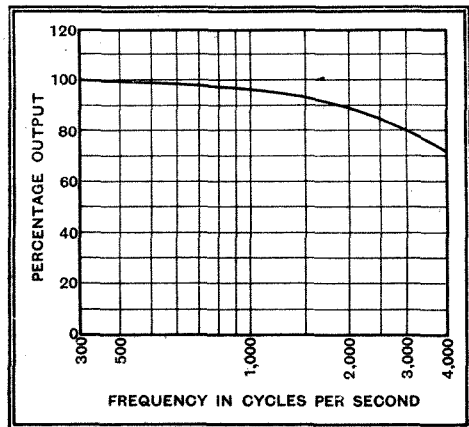

Fig. 7.—Attenuation due to finite slit width in 16 mm. recording.

suffers from the same difficulty as that mentioned for 35 mm. film. That is to say, the photographically fast emulsion required for obtaining the picture negative does not provide sufficient resolving power

to obtain the required definition on the sound record.

It is standard practice to run 16 mm. sound films at the same frame frequency as 35 mm. prints, that is, twenty-four pictures per second. This fact allows direct optical reduction of the picture from 35 mm. negatives. Now, because the film width is 16 mm. compared with 35 mm. for its full-sized brother, and because a picture frame proportion of 3 to 4 is preserved, the linear speed of 16 mm. film is approx. $\frac{2}{3}$ that of 35 mm.

AFTER discussing methods of sound recording that are adaptable to home or amateur use, the author goes on to explore the possibilities of sound-on-film (sub-standard size) gramophone records and other specialised systems of mechanical recording

The attenuation which occurs at a frequency of 10,000 cycles per second on 35 mm. records, due to finite slit width and photographic considerations, will occur in equal measure at only 4,000 cycles per second on 16 mm. records. This attenuation is a serious problem and means that very accurate control is necessary to obtain satisfactory sound quality. For the same reason it is preferable to make a 16 mm. print by optical reduction of the sound track from a 35 mm. negative rather than to re-record or record the sound

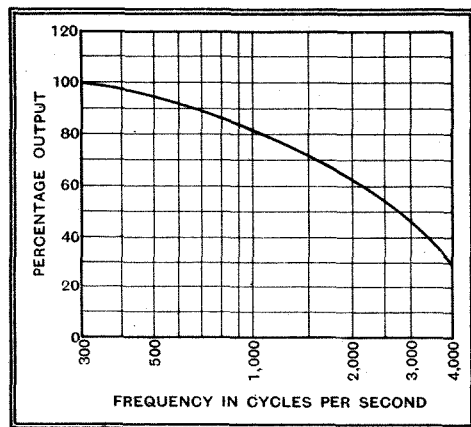

Fig. 8.—Losses due to lack of resolving power will increase inversely with the lower linear speed of 16 m.m. film.

directly on 16 mm. stock. This point will be further elucidated later in this article.

Volume range, on the other hand, is not so seriously curtailed, because a modulation depth of 0.060in. is maintained, compared with 0.075in. for 35 mm. variable area. A track of 0.060in. amplitude is obtained by utilising only one row of sprocket holes and placing the track where the second row would normally be on 16 mm. silent film. An increase in effective background noise is, however, inherent, and this causes a further slight decrease in volume range.

PART II.

SUB-STANDARD FILMS : MECHANICAL RECORDING : GENERAL CONCLUSIONS

With regard to direct recording on 16 mm. film, if we consider a two-channel system (that is to say, separate cameras and films for sound and picture), the overall result to be expected can be computed from the figures we have quoted in the 35 mm. case. In the first place the apparatus must be as accurately made and operated as in the 35 mm. system, and the only difference will be that we use 16 mm. film at a speed of 36ft. per minute. If we assume a recording slit width of 0.0005in. as the lowest reasonable size, the attenuation due to this alone will be as shown in Fig. 7. Now the losses due to lack of resolving power in the emulsion at any frequency will be increased in-

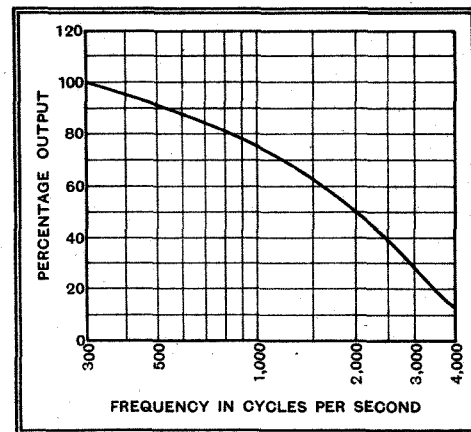

Fig. 9.—Overall high-note attenuation of the printed sub-standard film.

versely as the lowered linear speed, and will be as shown in Fig. 8.

If now we make a print by contact from the negative so obtained, a further loss will be introduced which will give a frequency characteristic for the final record approximately as shown in Fig. 9. Comparison should be made with Fig. 6 in last week's instalment, which relates to 35 mm. recording, to appreciate the losses involved. In addition the volume range will have been lowered by about 8 db., chiefly due to the effective noise level being increased.

Any method of re-recording in which a 35 mm. print is reproduced and the electrical output fed to a camera to record a 16 mm. negative will, of course, suffer from similar losses. It is often suggested that electrical compensation may be introduced to improve the frequency characteristic, but this is not a satisfactory solution, as it can only increase the track ampli-

Sound Recording—

tude at the higher frequencies. The mean recording level must therefore be lowered, with a consequent proportional increase in noise ratio, and the harmonic content at the higher frequencies due to lack of resolving power causing valley fogging will be so great that the remedy will probably be more unpleasant than the disease.

With a re-recording process the camera will normally make a 16 mm. negative, and this must be contact-printed to form a 16 mm. positive. The process will introduce another loss in frequency characteristic.

Apparatus has been developed and is in commercial use which will print a 16 mm. track by continuous optical reduction from a 35 mm. sound negative. Machines of this type have required concentrated study and development over a long period owing to the mechanical difficulty of propelling two separate films at their correct relative speeds in the ratio of 5 to 2. The optical system between the two films is of asymmetrical type and forms a track image reduced in linear ratio of 5 to 2 but a transverse ratio of 70 to 65.

In this system of making a 16 mm. print there are no losses in the process due to finite slit width, and the printing losses are small compared with those obtaining with 16 mm. contact printing.

With the optical reduction method the processing conditions are such that small improvements can be made in rather unexpected places. In the first place it must be realised that the conditions obtaining for 16 mm. sound tracks are not the same as the optimum conditions for 35 mm.

In establishing optimum processing conditions in either case, the ultimate test must be an aural one, and the same sound frequencies apply in each case. The conditions affecting emulsion resolution are, however, different, owing to the lower linear speed.

Overall Characteristics

In general this means that the 16 mm. unmodulated print track density is kept lower than is normal for 35 mm. work. In the case of variable density recording, this results in an increased output of 8 db., and in the case of variable area tracks the output can be kept up proportionately to the 35 mm. case owing to non-proportional contrast introduced by the printer coefficient of the optical printer.

Summing up, we can say that with a 16 mm. print made by optical reduction a frequency characteristic similar to Fig. 10 is obtainable. Direct recording to 16 mm. or a re-recording process will give a slightly inferior result.

Signal-to-noise ratio will be rather worse than for 35 mm. work owing to the general lowering of the total signal output caused by the curtailed frequency characteristic. Volume range will be slightly lowered by the smaller track width and still more by the increased noise level, but this is partly counterbalanced by gains which can be made in the processing operation. Volume expansion methods

can again be used to effect an improvement.

Turning to the question of mechanically recorded sound, the system with which we are most familiar is, of course, the conventional gramophone disc. This has a laterally modulated groove which traces a spiral when no sound is present, but traces the wave form of the recorded sound in the plane of the disc about the unmodulated spiral as axis. The discs

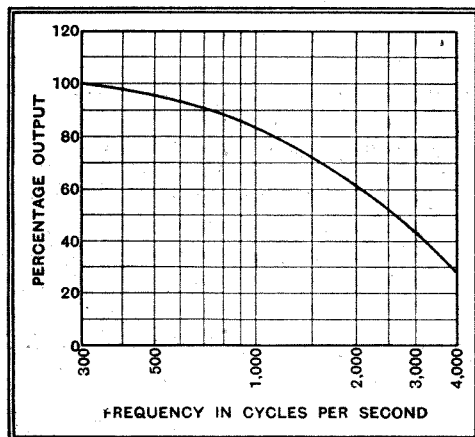

Fig. 10.—Approximate frequency characteristics that be obtained with optical reduction.

normally rotate at 78 RPM, and so for a 12in. diameter record the linear track speed progressively decreases from about 46in. per second on the outer diameter to 17in. per second on the inside.

The recording of a lateral-cut record is usually done with a chisel-shaped stylus having a flat front face with "vee"-shaped sides at an angle of 90°, tapering to a rounded base of approximately 0.002-in. radius. The groove is cut to a depth of from 0.002in. to 0.003in., and so the width of the track on the surface of the record is approximately 0.006 to 0.007in. It is usual to cut from 90 to 100 tracks to the inch, and so the available modulation amplitude is 0.002in. The maximum track amplitude, in conjunction with the inherent background noise or "scratch," determines the volume range available.

The original record is cut into soft wax, which is afterwards given a metal coating either by brushing on a conducting layer of graphite and then copper plating, or producing a metal layer directly by cathode sputtering. From this original "positive" is made a metal inverse, and from the latter the final commercial discs are pressed in one of a number of synthetic compounds.

As previously mentioned, a chisel-shaped stylus is used to cut the original wax, and this can be ground and maintained to fine limits. Such a stylus would, however, be prohibitively expensive and difficult to handle for reproducing, and so a round tapered needle with a rounded end is used. In order that the needle shall fit the groove as well as may be, it is normal practice to include a mild abrasive in the compounding of the disc material. After the first few turns this has something of the desired effect, but in itself

gives rise to a considerable portion of the resulting background noise. The remainder of the ground noise is chiefly produced by small random irregularities in the disc material.

A second limiting feature in this connection is that the track made by the recording stylus is not of constant width measured transversely to the direction of travel of the stylus at any instant.

Thus the reproducing needle is not held firmly by both sides of the track at some points, but is partially free to weave from side to side. The effect is obviously more serious at higher frequencies, and is one of the limitations to the frequency range available from this type of record.

Standard of Quality

With regard to the standard of quality we may sum up by saying that it is usual to cut the frequency range sharply above about 4,000 cycles to maintain the signal-to-noise ratio of permissible value, and the volume range available is about 25 to 30 db.

It is interesting to remember that the original Edison phonograph used a vertically modulated or "hill-and-dale" track, but this was discarded for various reasons due to the difficulty of building the mechanical apparatus of those days with sufficient precision. The Western Electric Company have more recently resurrected the system, and with modern technique have shown that it will give results superior to the more conventional recording.

The advantages are considerably concerned with the fact that the "pinch effect" illustrated in Fig. 11 is now absent, and it is not necessary to include an abrasive in the record material. Thus

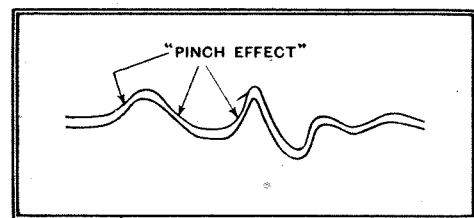

Fig. 11.—Illustrating the "pinch effect": the chisel-shaped cutter moves parallel to mean axis and not parallel to direction of track. This effect is avoided in "hill-and-dale" recording.

the background noise is reduced, with consequent increase in volume range and a permissible extension of the frequency range. It is stated that a volume range of 50 to 55 db. is available if the top frequency is limited to 5,000 cycles per second, while a range of 45 to 50 db. is available if the range is extended to 10,000 cycles.

It has been proposed to increase the volume range available from discs by using a combination of vertically and transversely modulated groove. If the vertical modulation is used for the sound recording in the normal way it is possible to modulate the vertical groove transversely at a low frequency to control the

Sound Recording—

amplification of the reproducer. This low-frequency signal would be filtered and made to control the bias of one of the amplifying stages. The recorded sound could then be automatically contracted during the recording process and expanded on reproduction.

The Philips-Millar system of recording combines a mechanically recorded sound record with optical reproduction, and has the advantage over a purely photographic system of instant playback and over the purely mechanical system of improved quality of recording.

The record is cut by means of a diamond-pointed stylus into an opaque coating carried by a flexible transparent base similar to photographic film. The cutter works in "hill-and-dale" fashion—that is, at right angles to the plane of the record—and, owing to its shape, produces a bilateral form of variable area track. A soft layer of transparent material between the opaque top surface and the supporting base absorbs the depth of cut.

The method has the immediate advantage that a maximum contrast is available between the density of the recording layer and the transparency of the support. Providing the cut is clean, no high-frequency attenuation takes place due to an imperfect wave shape in the way that is inherent in a photographic method. The substance forming the opaque top layer may be in a finely divided form, which thus improves the definition and minimises background noise. Lastly, the record is immediately ready for reproduction.

Limitations of the System

The disadvantages that can be cited when considering the system from a general point of view are, first, that most of the advantages are lost if copies of the record are made by photographic means. Secondly, the design of a cutter is not quite so straightforward as with the more usual means for modulating a photographically recorded track; and lastly, the system suffers in the same way as the usual photographic methods when used as a long-playing reproducer. That is to say, owing to track size a large bulk of record is necessary for a playing time of, say, two or three hours. The author is not able to quote performance figures for this system.

For a long-playing reproducer a record track similar to that on a gramophone disc offers one great advantage in that its small track size allows a considerable playing time to be obtained from a given size of record.

For home recording and for many other purposes the simplicity of the system and the possibility of immediate playback are very attractive.

It cannot, of course, be claimed that the method offers the most perfect sound quality, but the results will be acceptable for many purposes.

For these and other reasons a considerable amount of research is being devoted to methods of mechanically recording

sound on flexible base material in strip form. In this way it is possible to use a long endless loop of record stored on some form of endless re-spooling device and carrying a continuous helical track. A very long playing time with a minimum of easily handled material is thus available.

It is not possible to describe this system in detail at the present time, but it undoubtedly offers very great possibilities.

A well-known magnetic sound-recording

apparatus makes use of a semi-permanent rearrangement of the molecular distribution in a suitable steel strip or wire when subjected to a magnetic field alternating at speech frequencies. Paper and other similar record carriers coated with suitable magnetic material are also used.

A DC field is usually applied at the same time as the speech frequency field to bring the working point to a suitable position on the hysteresis loop of the material and ground noise eliminating methods are possible by controlling this bias flux.

The method has the advantage of immediate "playback," but suffers from the bulk of the record material and the difficulty of storing completed records.

The author is not able to state actual performance figures, but the system is in commercial use, especially for re-broadcasting purposes.

Various attempts have been made to form sound images by electro-chemical action. Usually a stylus riding on a conducting record material applies a potential gradient determined by the speech frequencies to be recorded. Electro-chemical action with a suitable material in the record base then produces discoloration which provides a variable density form of image.

The resultant record is reproduced optically by reflecting light from its surface on to a photo-sensitive device.

No commercial system has been worked out and it would seem that the method has too many practical difficulties to allow a satisfactory result.

A summing-up of this survey in the light of home recording requirements would suggest that photographic methods are too expensive and require complicated apparatus operated with considerable technical skill to obtain good results.

Mechanical methods will give satisfactory results with comparatively simple equipment, although the sound quality possible with the apparatus obtainable by the amateur at the present time is some way short of that theoretically desirable.

The conventional gramophone disc does not permit sufficient playing time and is not satisfactorily capable of operation in conjunction with a 9.5 or 16 mm. movie camera to provide "home talkies."

The record cannot be immediately "played back," and requires some after-treatment if reasonable sound quality is to be obtained.

A mechanical recording system using a flexible base in strip form would seem to offer greatest possibilities, and if this can be combined with the necessary photographic picture requirements may provide a satisfactory solution.

Television Programmes

The principal items only of each day's programmes are given. The system to be used each day is given below the date. Transmission times are from 3-4 and 9-10 daily.

Vision	Sound
6.67 m. (45 Mc/s).	7.23 m. (41.5 Mc/s).

FRIDAY, DECEMBER 4th.
(Baird.)

3.5, Dress Parade. 3.20, Film: "Australia—Harvest." 3.30, Cartoons by H. S. Foxwell of "Teddy Tail" fame. 3.45, Bob Wilton, comedian.

9.5, Dress Parade. 9.20, British Movietone News. 9.30, Repetition of 3.30 and 3.45 programmes.

SATURDAY, DECEMBER 5th.
(Baird.)

3.5, Starlight: Gillie Potter. 3.20, British Movietone News. 3.30, George Scott-Wood and his Six Swingers.

9.5, Starlight: "Hutch" (Leslie A. Hutchinson). 9.20, Film: "Australia—Harvest." 9.30, George Scott-Wood and his Six Swingers.

MONDAY, DECEMBER 7th.
(Marconi-E.M.I.)

3.5, Tex McLeod and his horse, "Arabia," spinning ropes and yarns. 3.20, British Movietone News. 3.35, Scenes from the Duchess Theatre production of "Murder in the Cathedral," with Robert Speaight as Thomas à Becket.

9.5, "Masks and Mimes," by H. D. C. Pepler, presented by Stephen Thomas. 9.25, Film. 9.35, "Cabaret Cartoon."

TUESDAY, DECEMBER 8th.
(Marconi-E.M.I.)

3.5, The Vic-Wells Ballet Company in "Façade." 3.30, Film. 3.45, Starlight: Sophie Tucker.

9.5, Demonstration by the Women's League of Health and Beauty. 9.20, British Movietone News. 9.35, The Vic-Wells Ballet Company in "Façade."

WEDNESDAY, DECEMBER 9th.
(Marconi-E.M.I.)

3.5, "Quarter-of-an-hour Meals," Moira Meighm will show what can be done with simple equipment in the preparation of good food. 3.20, British Movietone News. 3.35, Tenth Picture Page.

9.5, Repetition of 3.5 programme. 9.20, Film. 9.35, Eleventh Picture Page.

THURSDAY, DECEMBER 10th.
(Marconi-E.M.I.)

3.5, London Characters: Toni, the one-man band and Mike Stern, cheap-jack of Petticoat Lane. 3.15, Film. 3.25, Stage Scenery Design demonstrated by Peter Bax. 3.40, Carroll Lewis and some of his "discoveries."

9.5, Starlight: Ambrose with Evelyn Dall. 9.20, British Movietone News. 9.35, Ballet.

**Wireless for
Christmas**

Next week's issue will contain suggestions and advice on the choice of wireless as Christmas presents, and will also contain special articles on ideas for entertainment during the festive season.

Listeners' Guide

Outstanding Broadcasts at Home and Abroad

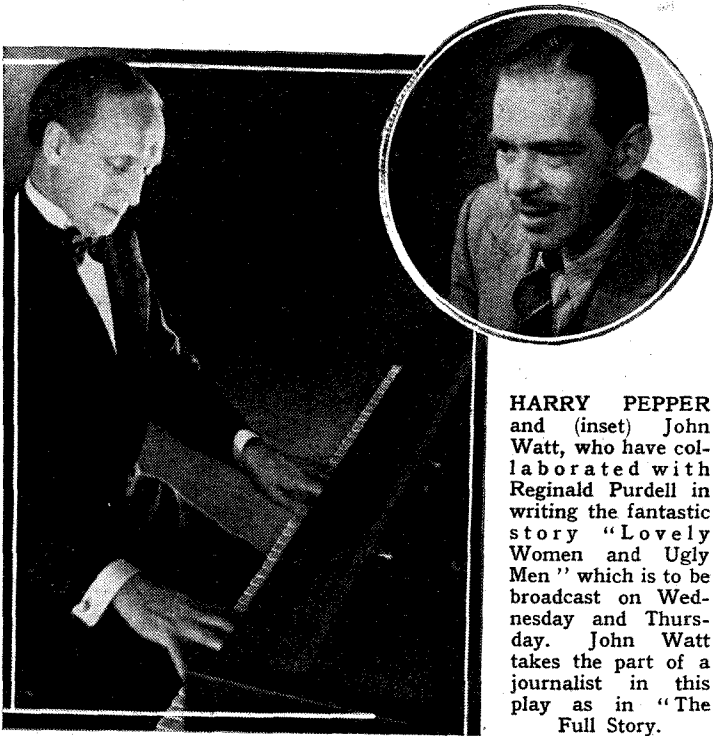

HARRY PEPPER and (inset) **John Watt**, who have collaborated with **Reginald Purdell** in writing the fantastic story "Lovely Women and Ugly Men" which is to be broadcast on Wednesday and Thursday. **John Watt** takes the part of a journalist in this play as in "The Full Story."

WE are again to have breakfast-time broadcasts from an English station, but only for a short time. It may be, of course, that if the broadcasts are enthusiastically received the Corporation may reconsider their decision on early-morning transmissions.

During the period of the first test match between Australia and the M.C.C. at Brisbane the B.B.C. are co-operating with the Australian Broadcasting Commission in providing us with eye-witness accounts of each day's play. Alan Kippax, the Australian cricketer, will give a close-of-play commentary for the benefit of English listeners at 8.30 a.m. The first day's play will be commented upon to-day (Friday) and on each succeeding day, excluding Sunday, for as long as the match lasts. For the sake of those who are unable to listen at this hour a recorded version will be transmitted at 1 p.m. daily.

COMIC OPERA

THE B.B.C.'s next contribution to the European Concerts arranged by the U.I.R. (Union Internationale de Radiodiffusion) is to consist of comic opera, representative of music from the British stage of the past two hundred years. It will include works by Arthur Sullivan, Edward German,

Montague Phillips, C. Villiers Stanford, Alfred Reynolds and Dibdin. The soloists will be Muriel Lee Petty (soprano), Jan van der Gucht (tenor), Percy Heming (baritone) and Harold Williams (baritone), who will be supported by the B.B.C. Revue Chorus and Theatre Orchestra.

The concert will be broadcast Regionally from 7.30 to 8.45 on Tuesday, when it will also be taken by the members of the U.I.R. and Nationally on Friday, December 11th. Stanford Robinson is returning to London from his Continental tour to conduct this concert.

AMERICAN ARTISTES

FAMOUS artistes of the American stage and screen will be broadcast from a studio on Tuesday at 8 in the National programme while rehearsing for the gala performance which is to be given at the Coliseum in aid of the King George Memorial Fund on the following Thursday at midnight.

It is hoped to broadcast per-

ALBERT SANDLER and the Park Lane Hotel Orchestra which will be heard from the Park Lane Hotel on Sunday.

formances by some of the following: Sophie Tucker, who has organised this gala entertainment, Marlene Dietrich, Richard Barthlemess, June Clyde, Ann Harding, Paul Robeson, and Laura La Plante.

MUSIC

SIR LANDON RONALD will on Saturday at 8 (Reg.) conduct Section D of the B.B.C. Orchestra in a programme which includes his own Birthday Overture, Sir Hubert Parry's "Lady Radnor's Suite for Strings," and Tchaikovsky's "Casse Noisette Suite." This programme was arranged for the summer, but owing to illness Sir Landon had to postpone it until he had sufficiently recovered.

Instrumental solos by members of the B.B.C. Orchestra will be given on Saturday at 6.45 (Nat.), the soloists being Terence Macdonagh (oboe), Richard Newton (bassoon), and Pat Whelan (saxophone).

Ethel Bartlett and her husband, Rae Robertson, will be heard in duets during a programme by the B.B.C. Orchestra (D) on Monday at 10.15 (Nat.).

The Sixth Symphony Concert will be relayed from the Queen's Hall at 8.15 and 9.25 on Wednesday (Nat.), when Sir Henry Wood will conduct the B.B.C. Symphony Orchestra, with Louis Krasner as solo violinist, who will give the first

concert performance in England of the late Alban Berg's Violin Concerto. This work, which was only completed shortly before the composer's death last year, was first performed by Krasner at the Festival of the International Society for Contemporary Music at Barcelona last year, and profoundly impressed all those who heard it. Louis Krasner, at whose initiative the Concerto was written, also played the solo part when it was broadcast by the B.B.C. last summer.

RUGGER AND SOCCER

THESE two sports will provide commentaries on four occasions during this week. On Saturday at 3.30 the National programme includes the third of the series, "Saturday Contrasts," during which F. N. S. Creek, the famous Corinthian, will describe part of the amateur soccer match between the Corinthians and the Royal Navy, from the Royal Naval Barracks ground at Chatham. From here listeners will be switched north to Wigan, where F. H. Pember-ton will comment on the last part of the Rugby League match between Wigan and St. Helen's Recs (Recreations).

The Oxford and Cambridge rugger match at Twickenham on Tuesday will be commented upon by Captain H. B. T. Wakelam between 2.5 and 3.25



Details of the week's Television programmes will be found on p. 595.

de for the Week

in the Regional programme. Another inter-Varsity match, this time the soccer battle between Oxford and Cambridge at the Arsenal Stadium, Highbury, comes into the Regional programme on Wednesday, when at 3.15 a running commentary on the second half will be given. F. N. S. Creek will again be the commentator.

BRITISH POLICY

At the present time, with much talk on British foreign policy, it is opportune that a debate entitled "Limited or Unlimited Obligations: A Discussion on British Policy" should be broadcast. Those discussing the problem will be Sir Edward Grigg, Sir Norman Angell and Mr. Harold Nicolson, with Mr. H. Wickham Steed, who as former Foreign Editor and Editor of *The Times*, has exceptional knowledge of world affairs, in the chair. This will be radiated by



ALAN KIPPAX, who will be heard at 8.30 each morning during the first Australian Test match.

HIGHLIGHTS OF THE WEEK

FRIDAY, DECEMBER 4th.
 Nat., 7.20, Recital: Arthur Cranmer (baritone) and Samuel Dushkin (violin). 8, The White Coons. 10.10, "Autumn Violin," featuring Jeanne de Casalis.
 Reg., 6, John Reynders and his Orchestra. ¶The B.B.C. Dance Orchestra. 8, British Ballet Music—B.B.C. Orchestra (D).
 Abroad.
 Vienna, 8, Contemporary Music.
SATURDAY, DECEMBER 5th.
 Nat., 3.30, Saturday Contrasts—No. 3. 5.15, Jan Ralfini and his Dance Orchestra. 7.30, "In Town To-night." ¶Jack Hylton and the Boys. 9.20, Music Hall.
 Reg., 4.15, The White Coons. 6, B.B.C. Military Band. 8, Sir Landon Ronald conducting the B.B.C. Orchestra (D). 10.25, Henry Hall's Hour.
 Abroad.
 Paris PTT, 8.30, Symphony Concert by the National Orchestra.
SUNDAY, DECEMBER 6th.
 Nat., 6.30, "The Table Under the Tree." 7.15, Foreign Relay. 8, Salvation Army Service from Clapton Congress Hall. 9.45, B.B.C. Theatre Orchestra.
 Reg., 5, Morris Motors Band. 6.30, Eighth Sunday Studio Orchestral Concert. 7.45, Service from Southwark Cathedral. ¶Albert Sandler and the Park Lane Hotel Orchestra.
 Abroad.
 Cologne, 7, Paul Lincke Evening—Operetta Music.
MONDAY, DECEMBER 7th.
 Nat., 6.40, Pianoforte Recital—Stanislas de Niedzielski. 7.20, Music Shop. 9.35, "Mr. Faithful"—Lord Dunsany's new radio play.

Monday, December 7th (cont.)
 Reg., 6, The Serge Krish Septet. 8.15, Roger Quilter's Opera, "Julia," from Covent Garden.
 Abroad.
 Leipzig, 7.10, Italo-Hungarian Evening from the Gewandhaus.
TUESDAY, DECEMBER 8th.
 Nat., 6.25, B.B.C. Northern Orchestra. 8, American Stage and Screen Tribute to the King George National Memorial Fund.
 Reg., 6, Friary Brewery Band. 7.30, Comic Opera. ¶Fred Hartley and his Novelty Quintet. 9.20, "Mr. Faithful."
 Abroad.
 Frankfurt, 7.10, "Der Trompeter von Säckingen," opera (Nessler).
WEDNESDAY, DECEMBER 9th.
 Nat., 7.15, "Lovely Women and Ugly Men." 8.15 and 9.25, Symphony Concert from the Queen's Hall.
 Reg., 6.40, The London Theatre. ¶George Scott-Wood and his Six Swingers. 9, The B.B.C. Theatre Orchestra and Anne Ziegler.
 Abroad.
 Paris PTT and Regionals. 8.30, National Orchestra and Dijon University Choir from Dijon.
THURSDAY, DECEMBER 10th.
 Nat., 6.40, Carroll Levis and his Discoveries. ¶Van Phillips and his Two Orchestras. 9.20, Introduction to Shakespeare's "King Lear," to be broadcast on Sunday, December 13th.
 Reg., 6, Worthing Municipal Orchestra. 8, "For All Ills." 8.30, "Lovely Women and Ugly Men."
 Abroad.
 Radio-Paris, 8.45, Weber Festival Concert.

the Regional transmitter at 9.20 on Saturday.

FOR THE SICK

JOHN CHEATLE is to present an original idea to listeners on Thursday at 8 (Reg.) and on the following Saturday (Nat.). It has been given the heading "For All Ills" and contains cures—to be taken neither internally nor externally—for minor ailments from sources of witchcraft, quackery, history, rustic tradition, and patent devices.

ANOTHER NEW OPERA

THIS time it is from the pen of Roger Quilter and bears the title "Julia." The heroine is the twenty-one-year-old widowed Countess of Clovelly, Julia, who has to make a choice between marrying one of two relatives of her late husband or lose her fortune. When she should meet these two suitors she runs off to a party at the Blue Boar Inn, where she meets David Wycombe, with whom she falls in love, and the romance progresses to a happy ending.

Only the first act is being

OPERA FROM ABROAD

THE week's programmes are marked by a scarcity of opera. Hans Pfitzner's "The Christmas Fairy" is Friday's only transmission of this kind and comes from Breslau at 7.15. On Sunday, from Radio-Paris, at 5.15, Paul Claudel's "Christophe Colomb" is being broadcast for the first time, wedded to music of Darius Milhaud, the most serious of the so-called "Group of Six" who form the select corps of contemporary French composers. Claudel is a distinguished diplomat and served his country as Ambassador to Japan and the United States.

Tuesday brings us a delightful and little-known opera from Frankfurt at 7.10. It is Nessler's "Der Trompeter von Säckingen," which was first produced in 1840 and swept Germany. On the same evening at 8, Rome relays from the Teatro Reale, Mascagni's "Nerone," conducted by the composer. Verdi's well-known "Falstaff" comes from Milan on Wednesday at 8.

SEPTUAGENARIAN

PAUL LINCKE, the well-known Berlin operatic composer, has just celebrated his seventieth birthday, and a special broadcast comes from Cologne on Sunday at 7, consisting of his works.



LEADING LADY and composer of the new opera "Julia," chatting at a recent reception of the British Music Drama Opera Company.

relayed at 8.15 on Monday from Covent Garden, the first scene in which is Julia's boudoir and the second the Blue Boar Inn. Margaret Bannerman makes her debut in light opera in the title-rôle and Henry Wendon plays opposite her as David Wycombe.

FINNISH

SUNDAY is the Finnish National Festival, and at 8.30 Warsaw is giving a Finnish concert with Finnish soloists. The concert will include works of Sibelius, Melartin, and Hannikainen.

THE AUDITOR.

UNBIASED

Do Women Lack Intelligence?

I WONDER if any of you who happen to be students of rodentology—or whatever this particular branch of Natural History is called—can assist me in a rather delicate matter relating to mice and women, between whom, as many of you may know, there exists an age-long enmity. The particular trouble which is plaguing me is unfortunately due to wireless and that is why it has been referred to me for solution.

Among my relatives I have a goodly store of maiden aunts of rather ancient vintage, the reason for this being that my grandfather lived in the good old mid-Victorian days when large families were considered the thing. This I know does not explain why they are still single, but the reason for this would probably be apparent to you were you to become acquainted with them. However, this is not what I wish to talk to you about and so there is no reason to become alarmed.

Now ladies of this type are usually possessed of what I may term the Sergeant-Major type of mentality, believing firmly in early Victorian virtues such as early rising and such-like horrors. It need hardly be said that to such people the early morning physical jerks broadcast by certain foreign stations round about 8 a.m. and such uncivilised hours of the day are a veritable God-send, and most of these good ladies are revelling in double-knee bends and other contortions beloved of the Sergeant-Major type of mind while you and I and other sane and sensible folk are still in our beds.

Remarkable Equine Sagacity

Unfortunately one of the most repellent of my aunts has been compelled to take to her bed, and is likely to remain there for some weeks, owing to her being kicked, quite justifiably, by an intelligent horse. Naturally wireless is one of her chief sources of amusement during the day, but unnaturally she wishes to listen in to these wretched morning programmes at an hour when none of the rest of the household is astir to switch the set on for her. Unfortunately her receiver cannot very well be transported to her bedside as it is built into a Victorian whatnot downstairs. By the way, in case there are any of my more modern readers who do not know what a whatnot is, I can only advise them to ask their grandparents as I cannot, of course, occupy the valuable space of this journal by giving a dissertation on Victorian ethnology.

Needless to say it was decided that I, as usual, should be the one to hold the baby, and I was duly summoned to the

Presence. Naturally I immediately suggested the purchase of a new receiver, but all the thanks I got for my pains was a severe lecture on the evils of extravagance and the painting of a mental picture of what would be my eventual lot if I persisted in my spendthrift habits. The upshot of the matter was that I agreed to lend her—or to loan her as I believe is the correct modern expression—a loud speaker and endeavour to construct a suitable arrangement for her to switch on the set in the morning.

Since the set was a battery-operated one I was unable to extend the LT leads to her bedroom on account of the question of voltage drop and I was therefore eventually forced to do the best I could with an alarm clock and a mousetrap of the breakback type. I arranged that by the aid of a piece of string connecting the alarm key of the clock with the mouse-



Duly summoned to the Presence.

trap, the latter should close the LT circuit with a firm contact at the appointed hour. The mousetrap was, of course, installed downstairs next to the set, and it was so arranged that when the string was wound up by the revolving key it fired off the trap. It would, of course, have been just as simple to arrange for my aunt to pull the string when she woke up, but I have never been one to miss the opportunity of exploiting the resources of science, and since the alarm clock was in use in any case, I thought it might as well do two jobs instead of one.

Now I flatter myself that this arrangement was absolutely foolproof, but this does not mean to say that it was proof against the appalling lack of technical instinct which seems to be every woman's birthright. It had not been working many nights when I received an S.O.S. to the effect that the receiver would persist in waking up my aunt with ribald songs from America at about 2 a.m. It seemed obvious to me, of course, that there must be some defect in the alarm clock which caused the set to be switched on in the

small hours of the morning, and since the wavelength to which the receiver was pre-tuned was also that of an American station the mystery was fully explained.

I was, however, greatly disconcerted when my aunt told me that it was nothing to do with the alarm clock, which was behaving itself in a perfectly respectable manner. I made a thorough examination and could only report that I found nothing wrong. Nevertheless the trouble continued, and it was purely by chance that I found that the whole cause of it was

By FREE GRID

that the fool of a nurse who set the trap every night had thought it necessary to stick a piece of cheese on it. I need hardly insult your intelligence by explaining what it was that had fired off the trap, although, of course, there were never any dead mice to be found as silent evidence since a modern mouse is naturally far too sophisticated to be caught out when extracting cheese from a trap.

Unfortunately the withdrawal of the cheese did not cure the trouble, and it seems obvious to me that mice must still be the cause of it although I, frankly, fail to see the reason why. This is the reason, of course, why I want any of you who may be students of mouse psychology to give me the benefit of your studies. As it is things are getting a little desperate, for I have been compelled to discard the mousetrap switch and get up at an unearthly hour every morning and hurry along to my aunt's house to switch on her set, and I don't mind telling you that the strain is beginning to tell on my health as I am none too robust.

Auf Wiedersehen

AS I am just about to cross over to the Continent on a mission of some danger connected with the forthcoming Christmas festivities in our village I will take this opportunity of wishing you all a happy Christmas, as it is by no means certain that I shall succeed in returning safely. I have, however, made special arrangements to transmit to you a few facts concerning my doings in the back of beyond. I am, as a matter of fact, bound for Iceland's greasy mountains and other delectable spots where the poet tells us that Father Christmas is accustomed to reside, and, quite frankly, between you and me, I am by no means looking forward to my mission, as I have got a very nasty cough. If, therefore, any of you ladies happen to have an old red flannel chest protector which you don't want I should be very glad to have the loan of it. I am off on Monday.

New Apparatus

Reviewed

Recent Products
of the Manufacturers

C.A.C. ALL-WAVE SUPERHET COIL UNITS

IN order to simplify the work of building an all-wave receiver the City Accumulator Co., Ltd., 18-20, Norman's Buildings, Central Street, London, E.C.1, are marketing as a separate unit the coil assembly used in their Austin all-wave sets.

Actually the coil unit is made in sections, each containing separate coils for each waveband, multi-point switch and padding condensers. There is one section for the signal frequency circuit and one for the oscillator. They are assembled on small aluminium panels and each is secured to the main chassis by two nuts.

It is designed for use with a triode-hexode valve, a 0.0005 mfd. gang condenser and an IF of 456 kc/s. With this size tuning condenser the wavebands covered on each of the four ranges were found to be 9.9 to 27.5 metres, 22.8 to 72 metres, 200 to 550 metres, and 780 to 1,875 metres respectively.

One great advantage of using a unit of this type is that the initial lining up of the set is simplified, for the coil units are tested and the various padding condensers adjusted before despatch. With half the adjustment already made it becomes a relatively easy matter to line up the IF amplifier, and then

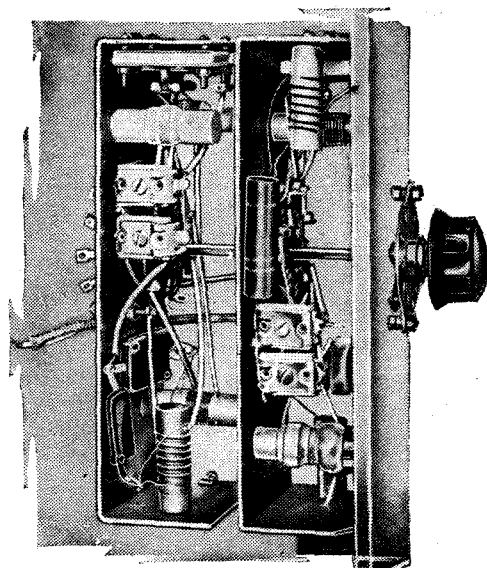

All-wave coil assembly made by C.A.C. and now available as a separate unit.

a few final adjustments to the various padding condensers can be tried to compensate for minor differences in stray capacities.

The coils fitted are quite efficient, and excellent results were obtained from a receiver embodying these coils. All the worth-while short-wave stations were tuned in without difficulty despite the size of the tuning condensers, though a good slow-motion drive is essential. The C.A.C. drive fitted to the test receiver was found to be very good indeed as it has a very large scale and is quite free from slip and backlash.

With only one signal circuit before the frequency changer a little interference from

second channel signals was occasionally encountered on the short waves, but it was not serious. As the coil sections are each entirely self-contained it would be quite practicable to add an RF stage and another coil section, and the improvements so effected would be well worth while on the short waves though it is not really necessary for the ordinary broadcast bands.

It is a well-designed unit and the coil assembly, which includes two sections as illustrated, costs 52s. 6d.

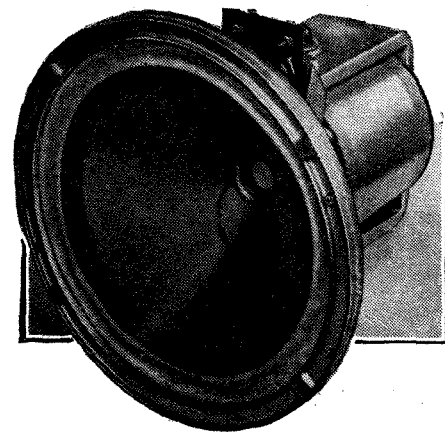

A recent addition to the Hartley Turner range of loud speakers in which the "Duode" principle of voice coil construction has been adopted.

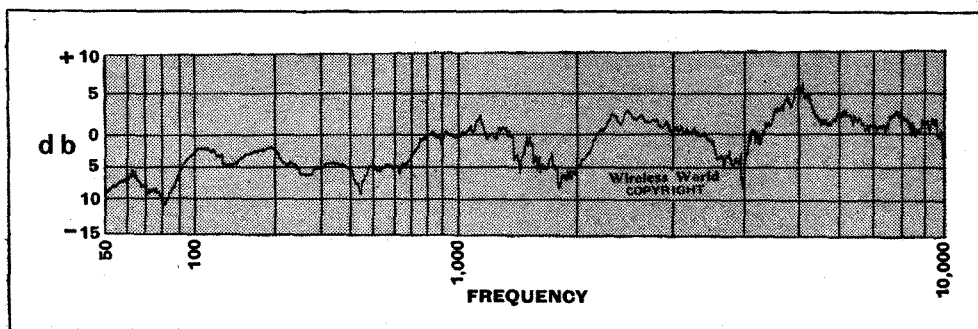

Axial response curve of Hartley Turner "Duode" loud speaker on irregular baffle (area approx. 22 sq. ft.), microphone distance 4 ft., power input 1 watt.

HARTLEY TURNER "DUODE"

THE application of the "Duode" principle of construction to the Hartley Turner loud speaker has still further improved the qualities of that instrument. For those who may not be familiar with the "Duode" principle, it is sufficient to state that the speech coil is wound on a light aluminium former which vibrates and becomes the active element at high frequencies by virtue of the eddy currents induced in it. Reference to the response curve shows that the output in the extreme top from just above 5,000 cycles to 10,000 cycles is flat within 2½ db. But the improvement in high-frequency response is not the only advantage which the "Duode" system has to offer, and at lower frequencies there is a marked increase in the damping control which is of special advantage in the reproduction of transients.

This increased damping is probably also responsible for a reduction in the 5,000-cycle peak which was prominent in the original design and which now is not more than 5 db. in height. There is also a reduction in the dip below 2,000 cycles, and in every way the curve of output against frequency has been appreciably smoothed.

The new design exhibits all the excellent qualities in the bass, and absence of modulation of high frequencies by low, which helped to establish the reputation of the first unit. It will be noticed, however, that the response below 100 cycles shows a new dip. This was found to be due to "belling" of the periphery of the diaphragm when supplied with a sustained input of 80 cycles. In the steady state not more than 500 milliwatts is necessary to maintain this "break-up" of the diaphragm, but under actual receiving conditions in which the applied

frequencies are continually varying no trouble from this effect was to be observed.

The price for DC excitation is £6 and for AC £7 5s., and an output transformer can be supplied to suit any type of output stage at an extra cost of £1.

KINGSWAY ELECTRICAL SMOOTHING CHOKE

KINGSWAY ELECTRICAL, LTD., of 3-9, Dane Street, High Holborn, London, W.C.1, have submitted for test a choke designed for use in *The Wireless World* Negative Feed-back Amplifier. It is of the shrouded type, and measurements showed it to have a DC resistance of 190 ohms with

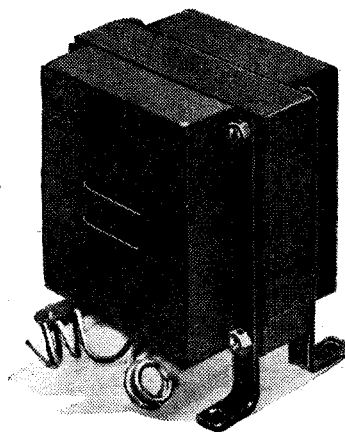

Smoothing Choke for the Negative Feed-back Amplifier.

an inductance of 18 H., when carrying 109 mA. DC. It is consequently a suitable component for this amplifier and it can be confidently recommended. It is priced at 10s.

BROADCAST

NEWS FROM
PORTLAND
PLACE

BREVITIES



INFORMAL INTERVIEWS can more readily be obtained by the Austrian Broadcasting Company by the use of this unobtrusive microphone which resembles an ashtray and is here shown in the centre of the table. Americans have for a long time made great use of diminutive microphones and transmitters and the one illustrated is of American origin.

The Dying Charter

ALTHOUGH the B.B.C. Charter expires at the end of the year, the Corporation officials go about their business with cold-blooded stoicism.

No sign is there at Broadcasting House that the minutes are ticking relentlessly on—no marking of calendars, no cutting of notches on sticks, no Omar Khayyám-like eating and being merry

Programme building goes on as usual; the New Year is already charted, and many programmes have already been devised to fill the first four months of 1937.

Poetry Crusade

EARLY in the New Year the B.B.C. hopes to run a poetry crusade.

Whatever our reactions to broadcast poetry—and there are hundreds of varying opinions on the subject—there is no gainsaying the fact that if poetry were a more solid and regular feature of the transmissions it would form a link between the musical programmes and the "spoken word" as represented by the talks and news bulletins.

An Outstanding Broadcast

The trouble with broadcast poetry in the past has been the lugubrious manner of its presentation. A brilliant exception was the reading of Tennyson's "Enoch Arden" a few weeks ago by Henry Ainley, with musical interpolations on the piano by Sir Hamilton Harty. In the hands of these two masters the long poem became a vivid recreation of life, utterly dissociated from the musty, Victorian drawing-room tradition which we moderns apply indiscriminately to all poetry having a semblance of rhyme and metre. The broadcast was a pleasant variant on the stereotyped Sunday evening Symphony concert,

and more of its kind might be attempted.

"The Poet Explains"

As a start we are to have two experimental poetry programmes in January, sponsored by an English poet of international reputation, and these are to be followed up by a series of six talks, each lasting an hour, entitled "The Poet Explains," to be given from 10 to 11 p.m. during February.

Portland Place will pay very careful attention to the "listener reaction" in this case, and if the response is encouraging, who knows what may follow?

Director of Poetry?

Is it too much to expect that a Director of Poetry may be appointed? Every other type of programme has its Director, but poetry is relegated to the care of the same official who handles talks on gardening, economics and food marketing schemes.

The choice of a worthy official might be difficult, but it need not be assumed that poetry is incompatible with bureaucracy. Several eminent poets of to-day are permanent officials in Government service.

Let the B.B.C. have the courage to appoint a Director of Poetry and the whole world will take notice.

A Television Christmas

MR. GERALD COCK and his production staff at Alexandra Palace are now collecting the ingredients for the special Christmas fare which is to be offered to the fortunate owners of television receivers throughout the week beginning December 21st. Although it is still too early to discuss the Christmas television programmes in detail, viewers may rest assured that an effort will be made to present as many all-star features

as possible. Most of the artists engaged will be celebrities from sound broadcasting, as well as from the stage and films.

"Picture Page" on Christmas Day

On Christmas afternoon it is hoped to present a special edition of "Picture Page," Cecil Madden's television magazine, in which interesting personalities from all walks of life—onion sellers, street performers, explorers, "people in the news," and other picturesque characters—face the television camera to relate their experiences.

There will also be a bumper programme between 9 and 10 on Christmas evening.

Christmas, 1936, will go down in history as the first Television Christmas, and everything will be done to make it a memorable one.

"The Run of the Play"

A NEW kind of commentary is to be tried at Twickenham on Boxing Day, when listeners will participate in the thrills of the second half of the rugby match between the Harlequins and Richmond. An attempt will be made to project "the run of the play." The broadcast will open with a description of what has gone before, with comments on the form of the various players and on Rugby in general. Gradually the commentator will work up to a description of the match after half-time.

A FIRST-RATE AERIAL.—This photograph, taken during Comdr. Attilio Gatti's recent expedition to the Belgian Congo, shows that there is at least one thing done better in the wilds than in civilisation. A native boy, making his own ladder with vines and fibres as he goes up the tree, hoists an aerial for the McMichael "Colonial" receiver which kept the party in touch with the world.



All of which goes to show that the "O.B." Department has not gone stale. New outside features are difficult to get nowadays, practically every source of entertainment having been tapped at one time or another. The fact that Mr. de Lotbinière and his staff are now seeking new methods of presentation is encouragingly significant.

New Station for the West

A SITE near Plymouth has at last been found for the high-power station which is to put Somerset, Devon and Cornwall on terms of broadcasting equality with Wales.

For many months the B.B.C.'s mobile transmitting and receiving vans have ranged the West Country in search of a site which would provide not only the necessary height above sea level but freedom from geological drawbacks.

Watchet for Wales

Assuming that the B.B.C. Charter is renewed and that the Government gives specific permission for the construction of the station, it is hoped that preliminary work on the site will begin in the late spring.

The new station will probably be completed by May, 1938, when Watchet will go "all-Welsh" in spirit, if not in language, and Plymouth (headquarters at Bristol) will have no further scruples about catering exclusively for its own listeners.

RANDOM RADIATIONS

By "DIALLIST"

Our Radio Trade

WHAT a big business we do in radio nowadays is shown by the October import and export returns, the latest available. Our exports and re-exports of wireless goods totalled just under £200,000 for the month and showed a favourable balance of over £30,000. Pretty good, you think? Well, so it is; though the position is not quite so satisfactory when you come to look into the figures in detail. For instance, the favourable balance on transmitting gear was a little under £30,000. It follows that on receiving equipment of all kinds we were just about all square in pounds, shillings and pence as regards exports and imports. But not in numbers: we exported 7,000 receiving



[N.B.C. Photo.]

TRAIN TO TRAIN. While speeding at 90 m.p.h. in the American streamlined train "Comet" a conversation by means of short-wave links arranged by the N.B.C. was conducted with a passenger travelling in a German streamlined train. Both trains were specially equipped by the respective authorities to carry out the experiment.

sets in round figures and imported 9,000; exported 214,000 valves and imported 260,000. So we were down to the extent of 2,000 receivers and 46,000 valves. But the most perturbing item is "parts and accessories." Here our exports were to the value of £51,427 and our imports to the value of £101,101. Why it should be necessary to spend this colossal sum (we spent more in September) on foreign radio components is rather difficult to understand.

When Valves Were Repaired

VALVES, I admit, are still dearer than they might be, but prices to-day are as nothing compared with what they were a dozen years ago, when a simple *bright-filament* triode cost 15s. or 17s. 6d., and dull emitters such as the DER, the DEV, and the DEQ could not be had under £2 10s. each. In those days valves were much more apt than they now are to expire through the burning-out of the filament. Some genius invented a process whereby blown-up filaments could be replaced, and for a time quite a business was done by certain firms in valve repairs. A hole about the size of a shilling was made in the bulb (I have forgotten, if ever I knew, how this was done; if you've ever tried to open a valve you know from experience what an implosion is!) and through this the old fila-

ment was extracted and a new one put into its place. I had several valves refiled in this way and they worked pretty well, though if one took their curves, as was one's wont in those days, they were apt to be strangely different from those of a new valve.

Radiotelegram

A WEEK or two ago I mentioned that telegrams sent by wireless were originally known as Marconigrams and later as Radiograms. The later word has now come to designate a combined wireless receiver and gramophone, and I wondered what was now the correct term for a wireless telegram. A correspondent who used to be a ship's wireless operator writes to say that he recollects the term Radiotelegram. I've verified this from the Post Office, and there is no doubt that radiotelegram is the official word in the British Empire to-day. I believe, though, that radiogram is still used in the United States, where the radio set-cum-gramophone all in one cabinet is much less frequently seen than it is here. Will some American reader please tell me whether I am right? If so, what word do Americans use for the instrument that we call a radiogram?

A Queer Fault

THE other day I came across a fault in a big radiogram which took quite a bit of tracking down. The instrument, which is of the highest quality, developed a most offensive form of noisiness. It began with mild cracklings which soon became so violent that they assailed the ears like a machine-gun barrage. Clearly a partial "dis"—but where? It was traced eventually to the milliammeter which acts as a tuning indicator. This is placed in the plate circuit of the second IF valve and carries all the HT current of that valve. Its windings had given way under the strain, and apparently the broken ends were vibrating, making an intermittent contact. One thing that surprised me was that in a set otherwise so good throughout a small, cheap milliammeter should have been used for this purpose. Any component which carries the whole plate current of a valve in a mains set has a good deal to put up with and should be soundly constructed. As the replacement cost 4s., it can't have been a very high-grade milliammeter!

The Aerial Question

A RECENT note of mine on the folly of spoiling the performance of good sets by working them off poor indoor aerials was misunderstood by one or two readers, who took it, for some reason or other, that I was attacking portable sets. Of course I wasn't. I was having a dig at those who buy receivers designed for use with an efficient external aerial and then handicap them by using them with very inefficient collectors, or even (as in the instance I mentioned) with none at all. The portable set is in quite a different category. It is specially designed to give good results from its own small built-in frame, and as a rule it is a very satisfactory piece of apparatus, particularly for those who cannot erect aerials, whether indoor or outdoor, of respectable height and length. No, I've nothing at all against the

portable; in fact, I use one quite a lot. But necessarily it has its limitations owing to the small size and the minute effective height of its collector. You wouldn't, for example, regard a portable as the ideal receiver for long-distance work.

Ant-proof Insulation

BRITISH wireless manufacturers have in the past been accused of neglecting the overseas market, but there are now signs that the peculiar problems affecting the design of sets for difficult climatic conditions are at last being taken more seriously.

For instance, it would appear that, in certain tropical countries, insulating material is liable to be eaten away by white ants. The Ekco firm, now busily engaged in developing the export side of its business, wants to study the matter at first hand, but the trouble is that white ants imported for the purpose do not seem to thrive in our English climate. Ekco is therefore searching for a strain of termites that, while remaining true to type, will retain their normally insatiable appetites long enough for the laboratory staff to find what kinds of insulating material are unpalatable to them.

NEW H.M.V. BATTERY ALL-WAVE RECEIVER

THE Model 166 just released is a four-valve battery superheterodyne with an undistorted power output of 1½ watts and provision for short-wave reception. There are three wave-ranges covering 18-50, 195-580 and 840-2,000 metres, the medium waveband occupying a vertical scale at the left of the cabinet and the long and short wavebands a corresponding scale on the right. Between the two is situated the permanent-magnet moving-coil loud speaker behind a curved bronze-mesh grille.

The first valve in the circuit is an X21

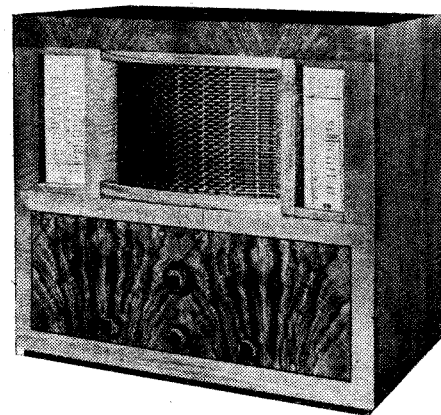

An attractive cabinet design has been adopted for the new H.M.V. Model 166 all-wave battery receiver.

frequency-changer preceded on medium and long waves by a band-pass filter. It is followed by a VS24 IF amplifier and a HD22 second detector, which also provides the AVC supply. The final valve is a QP21 double pentode, and the total HT consumption is rated at 7 mA.

There is provision for a gramophone pick-up, and the price of the instrument, complete with batteries, is 13 guineas.

Anson "Com

A RADIO-GRAMOPHONE WITH A LAVISH SPECIFICATION

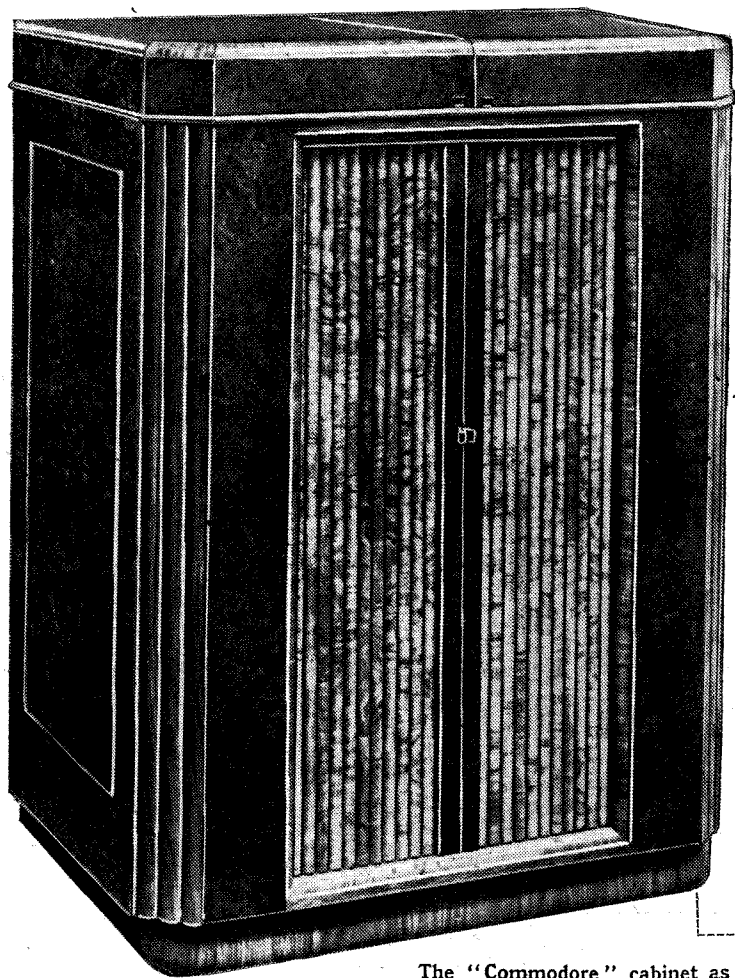

FEATURES.—Type.—Radio-gramophone for AC mains with automatic record-changer. **Waveranges.**—(1) 14-52 metres. (2) 175-565 metres. (3) 930-2,250 metres. **Circuit.—(Receiver)** Var.-mu pentode RF amplifier.—heptode frequency-changer—var.-mu pentode IF amplifier—double-diode second detector—triode AF amplifier—var.-mu pentode TI amplifier—double-diode TI rectifier—cathode-ray tuning indicator valve. Full-wave valve rectifier. **(Amplifier)** Triode first stage (all frequencies)—push-pull triode output valves (low frequencies)—triode first amplifier—triode output valve (high frequencies).—Two full-wave valve rectifiers. Westing-house metal oxide rectifier for loud speaker fields. **Controls.**—(1) Tuning. (2) Volume. (3) Waverange. (4) Noise suppression. (5) Bass tone control. (6) Middle tone control. (7) Top tone control. (8) Manual or auto record-changer switch. (9) Record rejection switch. (10) Master switch (radio, gram. and on-off). **Price.**—165 guineas. **Makers.**—Henry Anson Ltd., Harlequin Avenue, Great West Road, Brentford.

The "Commodore" cabinet as it appears when closed.

IN spite of the many points of technical interest in the circuit of this luxurious instrument, it is the record-changer unit which first focuses and holds our attention. This remarkable piece of mechanism is capable of giving five and a half hours of continuous entertainment from a single loading of records, for it plays both sides of each of thirty-three records before passing them to a re-

jection chamber at the side of the cabinet. Throughout this process the discs are handled with far greater care than they are likely to receive in the normal course of hand loading. A detailed description of all the processes involved and the many ingenious contrivances incorporated in the design would run into many pages, and it is here possible to touch only on a few of the salient features of the design.

Separate motors are used for the turntable and for driving the record-changing mechanism. The latter motor is reversible and is controlled by a relay. The first motion is to lift the records in the magazine until the top record in the pile engages with a traversing arm. This breaks a low potential electrical contact

Circuit diagram of electrical equipment. A standard special power amplifier in which high and low

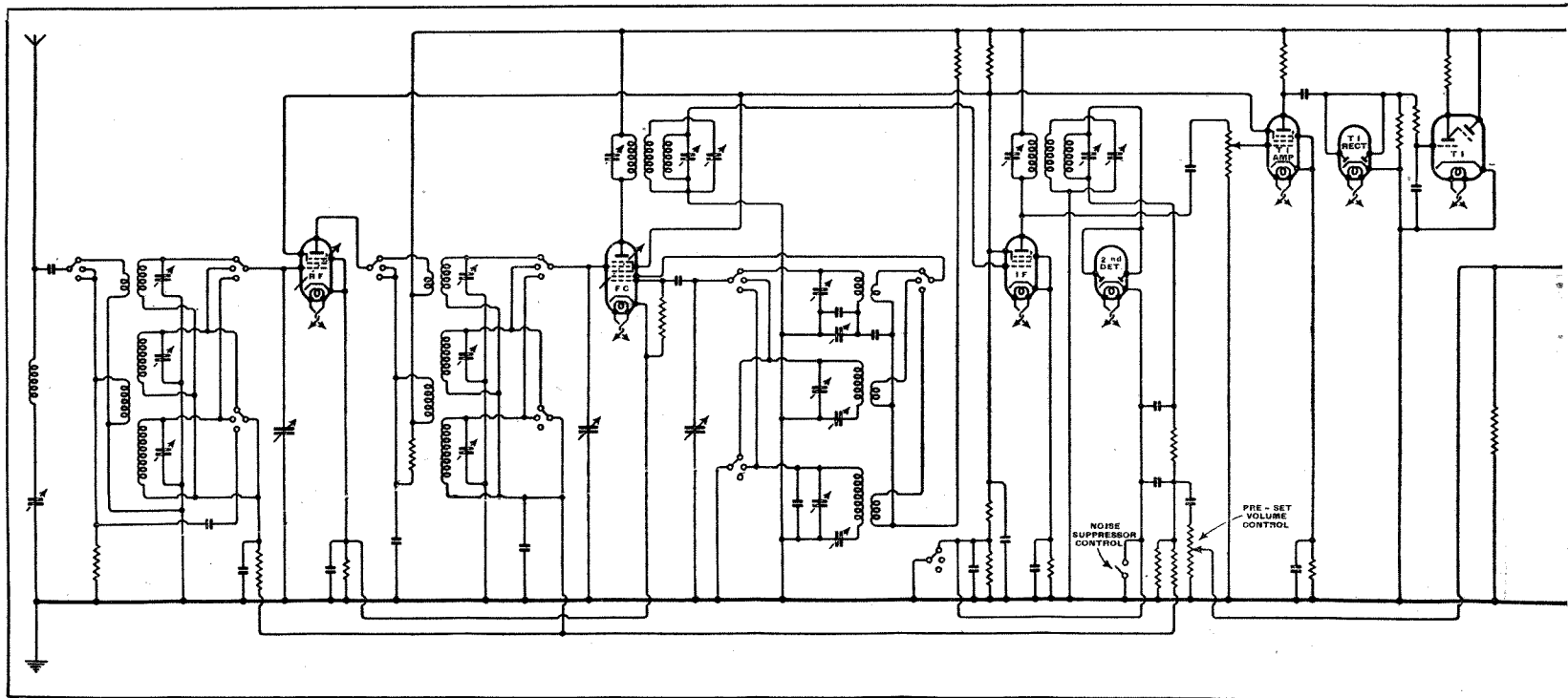

modore"

current if the record-changer should be working when one attempts to remove played records from the rejection chamber. Pilot lights on the control panel show the progress and completion of each record-changing cycle.

Starting with a record-changer of this calibre any radio-gramophone must be built up on a rather different scale from the ordinary product if incongruity is to be avoided. In this, in our opinion, the designers have been entirely successful.

between the arm and the vertical spindle upon which the records in the magazine are centred. The act of breaking this contact actuates the relay and reverses the motor, thus putting into operation the mechanism for loading the turntable. The turntable mechanism is hinged and is lowered out of harm's way when the record is in process of being turned over. Incidentally, by moving a lever it is possible to arrange for records to be played on one side only, and there is also provision for manual operation if this is desired.

A great deal of thought has been given to the method of feeding the pick-up needle into the first groove of the record. Gravity plays no part in this process, and it is probably for this reason that the instrument has proved eminently successful for use on board ship. The mechanism is well supplied with safety devices and it is virtually impossible to cause damage either to records or the mechanism itself through negligence. For instance, if one forgets to empty the rejection chamber and a record falls into a position where it might be damaged by the turntable mechanism as it is lowered, the first contact with the record opens a switch concealed in the push-rod which takes the weight of the turntable motor and instantly brings the mechanism to a standstill. Also a switch concealed in the hinge of the side door of the cabinet automatically switches off the

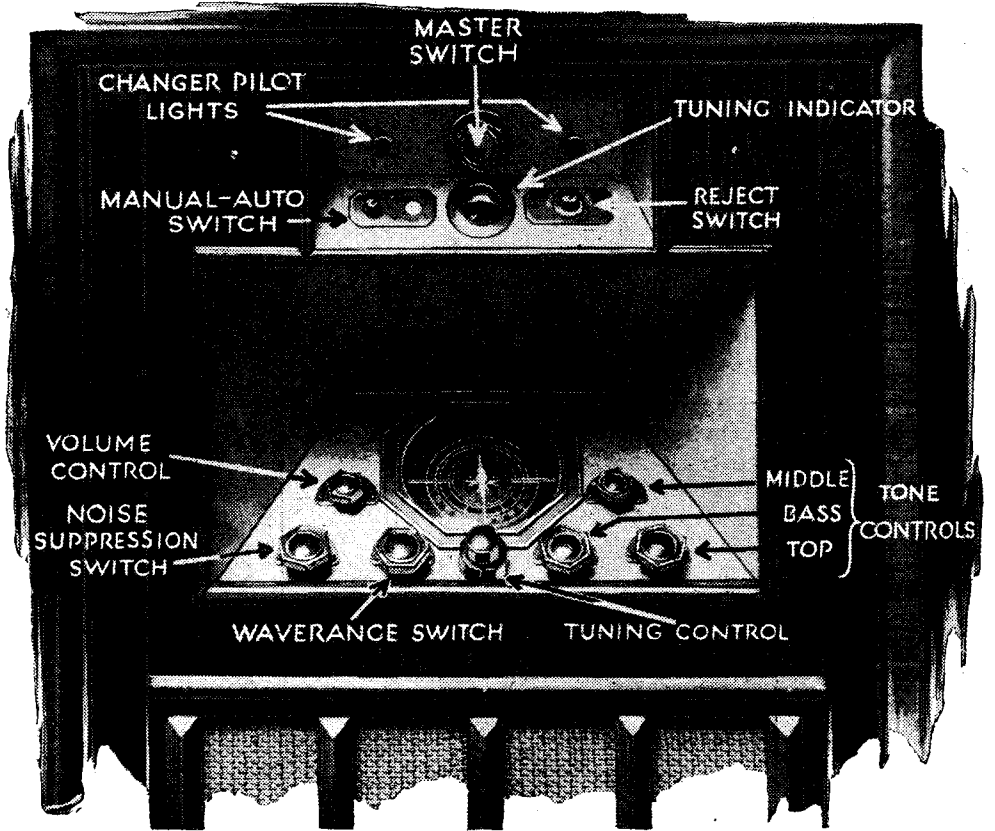

All principal controls for the operation of the record-changer and wireless receiver are concentrated on two adjacent panels.

The design throughout is on thoroughly sound engineering lines, and there has been no compromise with cost of production in effecting any simplification which might adversely affect either the efficiency or reliability of operation.

The cabinet is of the very highest quality and measures 3ft. 10in. high, 2ft. 10in. wide and 2ft. 2in. deep. It is solidly constructed and weighs approximately one hundredweight. Thus, quite apart from anything else, it is admirably suited

all-wave chassis has been adapted for use with a frequencies are amplified through separate channels.

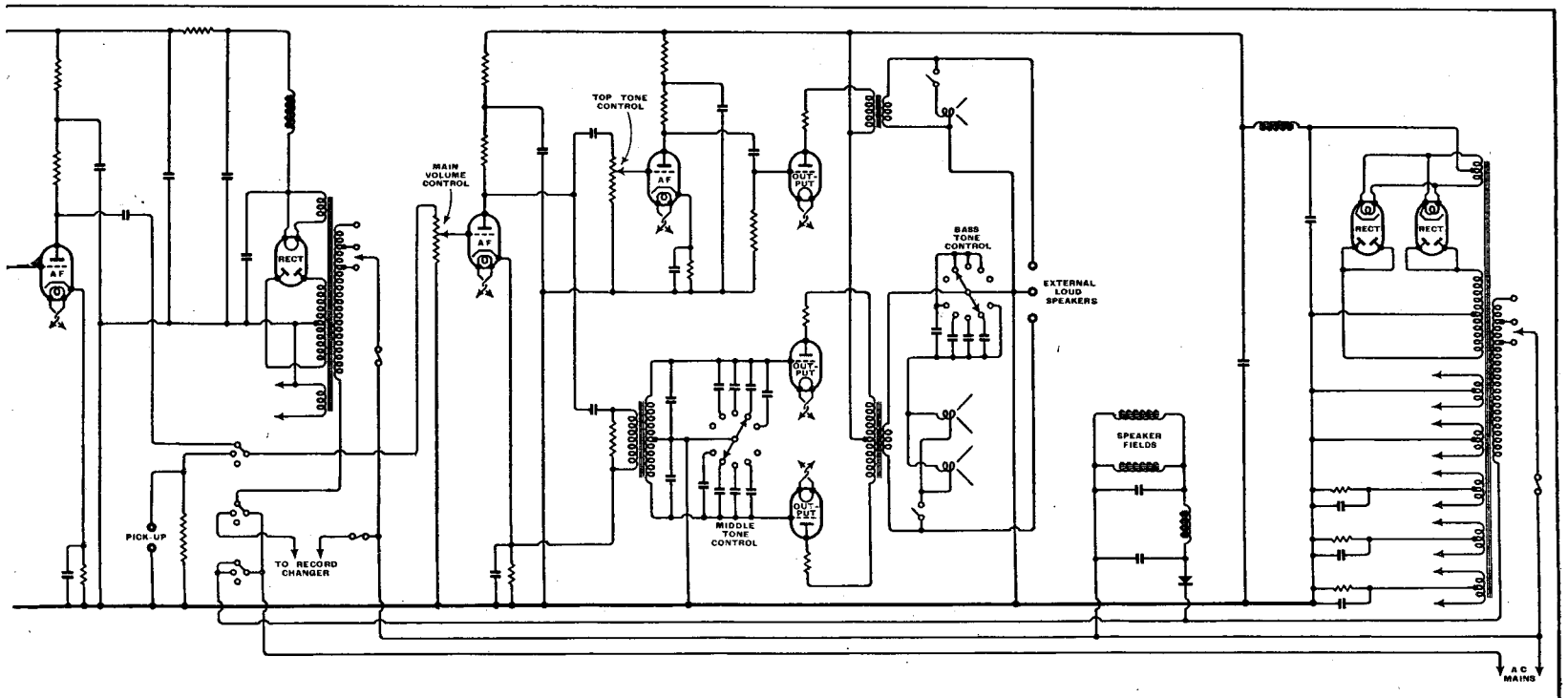

Anson "Commodore"—

to its function as a baffle for the three loud speakers, which can be supplied with at least 12 watts from the amplifying equipment. For radio reception an American-type chassis has been adopted and each receiver is rebuilt and suitably modified at the audio-frequency end to work into the separate power amplifier.

The input to this amplifier, whether from radio or gramophone, passes first to a triode which amplifies all frequencies and acts as a buffer between the input circuit and the frequency discriminating circuits which follow. The output from this first stage is "bifurcated"—to use the makers' own term—by parallel resistance-capacity couplings in which the values have been suitably chosen to effect a separation between high and low frequencies. The coupling passing the

no deficiency in this important section of the sound spectrum. A single small diameter permanent-magnet moving-coil loud speaker is used for the high notes, and two large-diameter energised units in

push-pull intervalve transformer, and the high-note tone control consists of a volume control potentiometer in the input circuit to the high-frequency channel.

The introduction of a control for the middle register is most useful, as, due to

The gear is assembled in two self-contained units, the record-changer (right) and the radio and audio amplifying equipment (below).

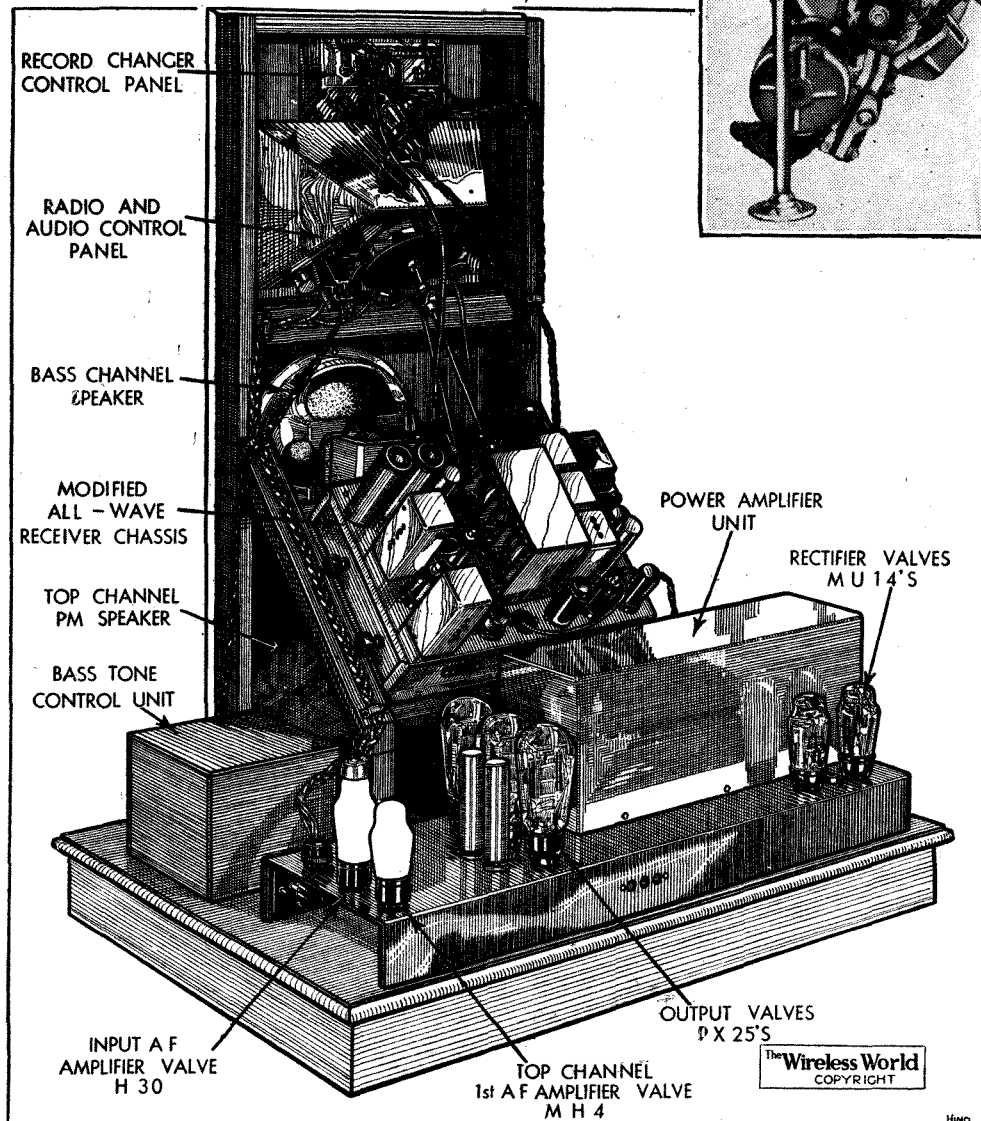
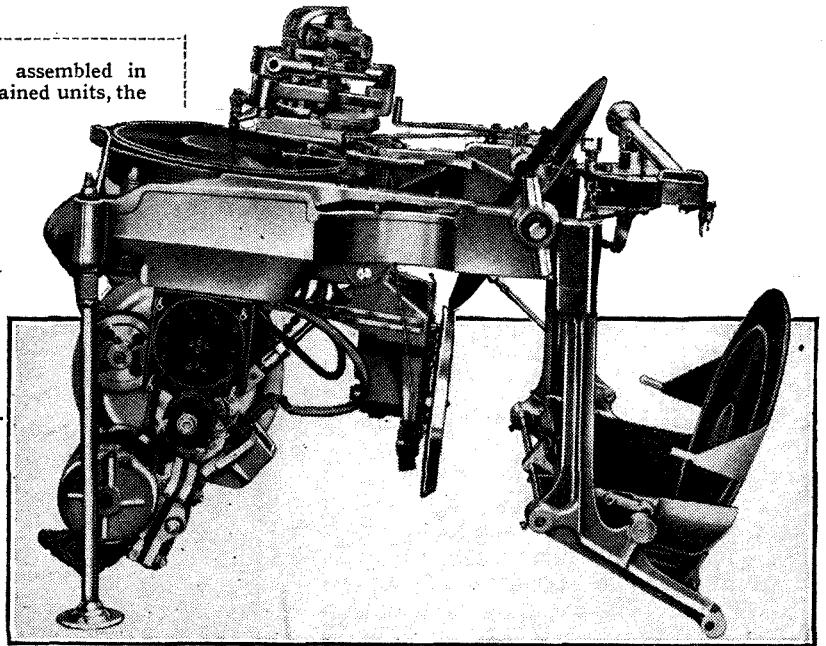

the sensitiveness of the ear in this region, the extreme high- and low-frequency response is apt to be masked at low volume levels. With a tone control in the middle register a much better aural perspective is maintained when the instrument is turned down and is merely serving the purpose of providing a musical background.

Quality to Choice

In assessing the quality of reproduction it is necessary to bear in mind that the makers have not attempted to give a "straight-line response" or to impose in any way their own ideas of what constitutes good quality. This is an instrument in which there is full scope for self-expression on the part of the listener. The reserve of power and range of control in the three sub-divisions of the musical scale is sufficient to provide an endless variety of effects—if necessary even to the point of caricature. The double basses, for instance, can be brought forward from their usually obscure place at the back of the orchestra to the status of solo instruments grouped round the conductor's rostrum; or the brass can be given an "edge" which will penetrate any amount of overlaying by other instruments. However, if one requires the usual compromise in the balance of tone the settings of the tone controls which give this result are soon discovered. If the top control at first seems a little critical in achieving a true top response without a certain hard brilliance, there can be no doubt about the smoothness of the two lower controls. It is, perhaps, in gramophone reproduction that the fine bass response is best appreciated, and there can be no doubt that

lower frequencies feeds into a high-impedance transformer supplying two PX25 valves in push-pull. The output valve for the high-frequency section is a single PX25, since the energy contained in this band is considerably lower than that found in the lower half of the frequency scale. Resistance-capacity coupling is employed throughout this channel, and an additional stage has been added to ensure that there shall be

parallel give the radiating area necessary for adequate reproduction of the extreme bass.

There are no fewer than three independent tone controls. The first, which controls the bass response, consists of a pad of condensers connected in series with the speech coils of the two larger moving-coil units. The middle frequencies are controlled by shunt condensers across the secondary of the

Anson "Commodore"—

the content of any record will be enlarged and enriched when played through on this equipment.

The radio receiver gives a performance which is fully in keeping with the scope and quality of the remainder of the instrument. All the range that one can possibly use is there, and adjacent station selectivity is possible in all cases with the exception of the locals, where not more than one channel is lost on either side of the normal setting of the station. The reception of American broadcasting on the short-wave range calls for no more skill or concentration than is necessary in operating the set on the medium-wave band.

Apart from the omission of the final AF stages, the only important alteration to the chassis as originally designed is in the provision of a separate amplifier and rectifier for operating the cathode-ray tuning indicator. The radio chassis has its own power supply unit, and the set is completely cold when the gramophone records section is in operation—an important point in view of the length of performance of which this side of the apparatus is capable. A third rectifier of the metal-oxide type supplies the field current for the two energised speakers.

The whole of the amplifying and receiving equipment, together with the unified control panel, is assembled in a framework which can be withdrawn from the cabinet as a single unit. At the back there are sockets for connecting external loud-speaker units and also sockets for remote electrical control of the record-changer unit. The latter is effected through a subsidiary low-voltage relay system.

The price is not within the reach of everyone, but those who can afford to indulge themselves will have the satisfaction of possessing an instrument which can have few rivals in the completeness of its electrical specification and the ingenuity of its record-changing mechanism.

**DISTANT
RECEPTION NOTES**

YOU may have noticed that Prague No. 1 is not much of a signal just now even after dark. The reason is that its usual 120 kilowatts have been reduced temporarily to a mere 5. Prague No. 2, on 259.2 metres, is out of action altogether at the moment. I have not heard the reason for these goings-on, but I suppose that extensive alterations must be taking place in both the Prague transmitters.

If Prague is silent, or nearly so, Lwow has found a new voice, for the 50 kilowatt transmitter is now at work on 377.4 metres. The wavelength is shared with Barcelona EAJ1, but when this is silent the Polish station comes in well. The old Lwow transmitter was rated at 16 kilowatts. In pre-Lucerne days it worked on 385 metres, and three years ago it used to come in strongly. Then it suffered badly from heterodyne troubles towards the end of the Prague Plan. Under the Lucerne Plan the

16-kilowatt station was usually rather a "chancy" station, coming through well at times, but being often unreceivable.

The French North-African zone is to have a new station, and a high-powered one at that. Morocco already has its 20-kilowatt, Rabat and Algiers its 12-kilowatt transmitter. Tunis is to have one of 100 kilowatts. It may be some time before the station is ready, for the plans have still to be passed.

I have seen it stated that Radio Lyons, the privately owned French station which works on 215.4 metres, has just increased its power from 5 to 25 kilowatts. But the increase took place months ago, and for a long while now this station has been strongly received. I may be unlucky, but I seldom find the programmes of Radio Lyons sufficiently attractive to induce me to listen to it for very long.

Some time ago I mentioned that a station intended to work on a wavelength in the neighbourhood of 300 metres was under construction at Singapore. I now hear that the work is so well advanced that the station may be testing almost at once. The power is, I believe, 20 kilowatts. Singapore time is 7 hours ahead of our own. As closing down time will probably not be later than 11 p.m. local time, the only chance of hearing the station will be on a mid-winter afternoon shortly before 4 o'clock.

Transatlantic reception has been pretty good of late, and more than once I have picked up U.S.A. stations before midnight. This is possible, of course, only when an American station happens to fit into the gap left by some European station that has closed down. One such gap may be found just above Radio Normandie when Moravska-Ostrava and Kuldiga have finished for the night. When conditions are good WPG on 272.6 metres occupies it and may be heard soon after 11 o'clock.

There is no question that many of the late night heterodynes that mystify some listeners are of transatlantic origin. If you find a whistle where there was none earlier in the evening and make a note of the dial reading you are almost certain to find an American station just above or just below it when you go back to it after the European station has signed off.

Nor am I sure that it is U.S.A. stations alone that cause surprise heterodynes in Europe. The South American stations have been coming in so strongly from a comparatively early hour onwards that some of them may also be "guilty." So far, though, I have not succeeded in catching any of them in the act. **D. EXER.**

Wireless Servicing Manual. By W. T. Cocking. Second edition, 231 pages + x, 85 illustrations. Published by Iliffe and Sons Ltd., Dorset House, Stamford Street, London, S.E.1. Price 5s. 4d. post free.

THE second edition of this well-known book has been extended by the inclusion of much extra material. All the matter of the first edition is included, but an additional 18 pages of new information have been added, thus increasing the scope of the book and keeping it thoroughly up to date.

The new material includes chapters on short and ultra-short wave apparatus and on the connection of extension loud speakers and other subsidiary apparatus. The appendices have also been revised and now include wire tables, the newest American colour codes, as well as the latest valve base connections.

McCARTHY LATEST!

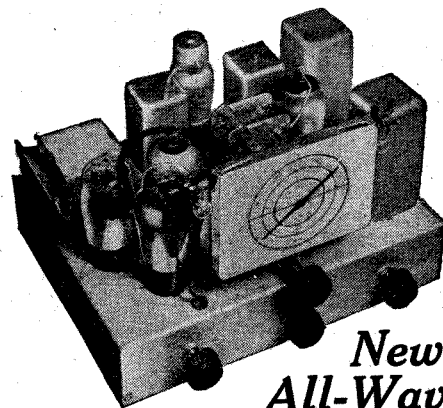

**New
All-Wave
SUPERHETERODYNE**
for
£6.15 (complete with B.V.A. Valves)

Though employing only 5 valves, the performance of this new McCarthy receiver on all 3 wavebands is comparable with that of many larger receivers at considerably higher prices.

Illuminated "Airplane" dial with principal station names. Wave ranges covered: 17-50, 200-550, 800-2000 metres. Built on heavy cadmium-plated steel chassis. Employs Varley iron-cored I.F. coils.

Circuit comprises: Pre-selector circuit coupled to triode-hexode frequency changer, transformer coupled to high efficiency H.F. pentode I.F. amplifier, I.F. transformer coupled to double diode-triode detector (D.A.V.C. applied to preceding valves), R.C. coupled to steep-slope output pentode giving approximately 3 watts. 4-position wave-range switch provides for gramophone reproduction. Volume control and variable tone control operate on radio and gramophone.

**"De Luxe" Model
McCARTHY ALL-WAVE SIX**

with
radio frequency
stage



£9 (complete with B.V.A. Valves)

"De Luxe" 6 valve receiver with 8 valve performance (specially recommended for tropical and foreign reception conditions). Built on special cadmium-plated 16 gauge steel chassis. Varley iron-cored I.F. coils. Litz-wound tuning coils. 3 wave-ranges—16.5-2000 metres. Illuminated "Airplane" dial with principal station names. Micro-vernier 2-speed drive.

Circuit comprises: Pre-selector, radio frequency amplifier (operative on all wavebands), triode-hexode frequency changer, double band-pass coupled I.F. amplifier, double diode-triode detector. D.A.V.C. applied to 3 preceding valves. L.F. amplifier and pentode output. Variable tone control and volume control operate on radio and gramophone.

All McCarthy receivers supplied complete with valves, knobs, pilot lamps, leads, mains cable and plug. 12 months' guarantee.

Deferred terms on application, or through London Radio Supply Co., 11, Oat Lane, E.C.2.

Cash with order on 7 days' approval. Also write for illustrated catalogue of complete range of all McCarthy receivers.

McCARTHY RADIO LTD.
44a, Westbourne Grove, London, W.2

Telephone: Bayswater 3201/2.

Going Down

IN the great wavelength share-out at Washington in 1927 there was a keen scramble for long and medium waves. Quite a lot of room was at that time still left among the short waves, but it was rapidly being used up, and the whole lot was, therefore, apportioned to the various interests. But when it came to waves below 13 metres nobody displayed any enthusiasm, so two bands were thrown to the amateurs and the rest were left unclassified.

It was the custom on such occasions to hand out to amateurs a few wavebands for which nobody else saw any utility. With regard to these ultra-short wavebands, the general impression was that they were no good; or, alternatively, if good, there were so many of them that nobody needed to worry about being crowded out.

It is true that even if one leaves out of account the almost unlimited "micro-waves" below 1 metre, the number of "channels" of any standard width is enormous when compared with the total of those provided by the longer waves.

From 10 metres to 20,000 metres there is room for 3,331 channels each 9 kc/s wide. From 1 metre to 10 metres there is room for 30,000. It also seems to be true, despite many surprises in the way of long-distance reception, that the majority of these are restricted to local ranges, and

A "RUN" ON THE ULTRA-SHORT WAVELENGTHS

minent place in the elbow-room problem by not "playing fair." While radio telegraph authorities look askance at broadcasters for occupying bands as wide as 9 kilocycles per station, television goes and annexes bands of about 5,000 kilo-

By "CATHODE RAY"

cycles each! Such wholesale appropriation naturally puts a different face on the matter. If ultra-short waves had no other use than for television, there would still be cause for counting them rather anxiously to see if there were enough. But what may not be so well known is that the same would apply if there were no television at all!

Once again, what *are* all these applications for space in the ultra-shorts? I have mentioned amateurs; they have two bands approximately 10-10.7 and 5-5.35 metres, and have justified use of them by demonstrating their utility and by public service on such occasions as when communi-

between two trucks somewhere along the train. So ultra-short wave sets are used. In France they are used in shunting yards and at the port of Rouen. The fighting services use them to co-ordinate their increasingly mobile forces. Police can spread a wide and fast-moving net over the criminal by means of a fleet of cars in continuous two-way touch with headquarters.

The advantages of ultra-short waves for this sort of thing are that a small portable aerial is able to radiate efficiently; that, except for motor ignition, there is hardly any interference; and that the simple, compact, but highly sensitive super-regenerative receiver is most effective on these waves, and is immune to a useful degree from what interference there is. And, of course, there is the advantage for them that the longer waves are all booked up.

Post Office Telephone Links

There are fixed communications, too. Instead of extending the telephone system across the channels around our islands by means of cables, which are expensive to lay, and expensive to maintain where ships' anchors and tides drag at them, our Post Office now puts up quite simple ultra-short wave stations which can work unattended. There are twelve "lines" to Ireland between 4 and 6 metres; and a number of others elsewhere, including a span of no less than eighty-five miles between Dorset and the Channel Isles. This, by the way, is 73 per cent. longer than the "optical" range that used to be considered the maximum, at any rate for reliable service. There is—or was until the present acute misunderstanding arose between the two termini—a link between Barcelona and Majorca, 120 miles, with only 10-watt transmitters, working unattended on 4.5 and 5 metres. In America there is one of these telephone links at Cape Cod working on about the same wavelength, and they are used farther afield still, in Hawaii. A different sort of ultra-short wave link is the one across New York harbour, which enables a transmitter on an island to be controlled from the shore.

The ease with which ultra-short waves can be directed is applied in certain blind landing systems for aircraft, now being installed at most public aerodromes, and in the same class there are direction-finding beacons.

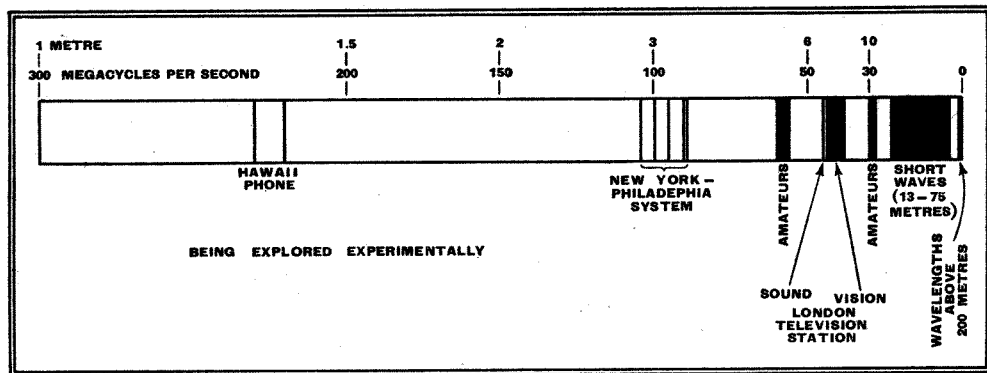

Frequency distribution of wavelengths above 1 metre (frequencies up to 300 megacycles/sec.). Note the wide band occupied by one television station compared with all bands above 200 metres.

that there is, therefore, no objection to working a large number of transmitters on the same wavelength.

But so rapid has been the discovery of the value of these wavelengths for many purposes that already there are not enough of them to satisfy everybody concerned.

What are all these uses for the ultra-shorts that seem to have been quite suddenly discovered? Television everybody knows about, of course. Besides having forced itself into a prominent place in the public eye (sorry, that was really quite unintentional!) by sheer weight of publicity, it has also forced itself into a pro-

cessions broke down during the American floods of 1936.

The features that make ultra-short waves so useful for this sort of work are being recognised by many besides amateurs. Engineers engaged on large structures such as bridges or pylons use "transceivers" to give instructions to or receive reports from men up aloft. Prospectors, explorers, and surveyors use them to keep scattered parties in communication. In America, the land of gigantic trains, there is a real need for communication between driver and guard, and it has to be a link that does not snap like that

Going Down—

Broadcasting authorities, already in-sufferably overcrowded elsewhere, have not left the ultra-short waves unconsidered. There are certain difficulties arising out of their position as a public service, but the establishment of regular television may tend to reduce these. High-fidelity enthusiasts hope that if broadcasting is done on these waves it will be allowed considerably more than 9 kilocycles per channel, so that selectivity and quality need not be mutually destructive; and broadcasters are considering the advantages of being able to cover "dead spots" with a number of comparatively cheap relay stations working if necessary on a common wavelength. The American station W8XH on 7.3 metres has already made a favourable impression.

Long years ago the B.B.C. pioneered short-wave outside broadcast links where telephone lines were impracticable; for example, in broadcasting the Boat Race, and the first Old Vic relay. Ultra-short waves are now used quite a lot in America for this sort of thing, e.g., interviewing pedestrians, and giving running commentaries on golf matches.

The idea—which is fast becoming illusory—that there is unlimited band-width between 1 and 10 metres has attracted other claims by wide-band systems besides those of television. Armstrong (of super-regenerative and other fame) has demonstrated a system of frequency-modulation depending on an expansion of band-width in order to improve the signal/noise ratio. Double-modulation systems are coming into use, whereby instead of the carrier wave being modulated direct with the phone or morse signals it is modulated by a number of radio-frequency waves, each of which is in turn modulated by the audio-frequency signals, which can be separated by means of suitable tuning circuits after the first detector in the receiver. Besides leading to economies, this multiplex system gives some degree of secrecy.

Further Television Requirements

Between New York and Philadelphia there is a multiplex system—two pictures, two automatic typewriters, and one telegraph, in each direction simultaneously—relayed by two unattended stations *en route*, the whole working on six wavelengths close to 3 metres.

Then there will have to be some means of "S.B.-ing" television, and linking up the transmitters with outside broadcasts. Cables for carrying the necessary wide-frequency band are enormously expensive and may never be generally available. It looks as if radio links will be used, and of course they must be at least as wide-band as the television broadcasts themselves.

Some, at least, of these systems that seek a place in the ultra-short waves because of their wide band requirements will have to go below 1 metre into what is generally known as the "microwave" region. The cross-channel circuit from

PRINCIPAL BROADCASTING STATIONS

There being no important changes in our usual monthly lists, these pages have not been included in this issue.

Lympne to St. Inglevert on 17 cms. has had few neighbours in wavelength during the several years since it was installed; but this solitary state may not last much longer. Apart from the enormous width of the frequency band available, these waves offer certain exclusive possibilities. Experimental systems of radio-directed navigation in Germany with 10 cm. waves have shown that a beam only one-tenth of a degree is practicable. This is done with parabolic reflectors just like a beam of light.

Then there have been experiments—French this time, I believe—with a view to locating obstructions such as icebergs. The transmitter and receiver are mounted on opposite sides of the ship, and any exceptional reflections that would be caused by something in front are investigated by calculating angles and so forth, according to simple surveying principles.

Time would fail me to tell of other present and projected applications of ultra-short waves—airport and aircraft signalling, fire-fighting (both urban and forest), geophysics, film production, radio-meteorology, therapeutics—all are queuing up. The wide open spaces will soon be built-up areas.

WHERE THE PUBLIC CAN SEE TELEVISION DEMONSTRATIONS

Place.	Particulars.
Science Museum, South Kensington.	Free.
Waterloo Station.	Free to railway ticket holders (Southern).
Army & Navy Stores, Ltd., 105, Victoria St., S.W.1.	Free.
John Barker & Co., Ltd., High St., Kensington, W.8.	Demonstrations shortly.
Barries Radio (London) Ltd., 91, Ruislip Rd., Greenford, Middx.	Free at 9 p.m.
Bensted's, 22, Hill Street, Richmond.	Free at 3 p.m. and at 9 p.m. by appointment.
Bentalls, Kingston-on-Thames . . .	Demonstrations shortly.
Electrico (Croydon) Ltd., 97, George St., Croydon, and 30, Market Square, Bromley.	Free from 3-4 p.m. and from 9-10 p.m. by appointment.
A. W. Gamage, Ltd., Holborn, E.C.1.	Free.
General Electric Co., Magnet House, Kingsway, W.C.2.	Free.
Gramophone Co., Ltd., 98-108, Clerkenwell Rd., E.C.1.	By arrangement with their local H.M.V. dealer, readers of THE WIRELESS WORLD can have free demonstrations.
Hampton & Sons, Ltd., Pall Mall East, S.W.1.	Free from 3-4 p.m.
Harrods Ltd., Brompton Rd., S.W.1.	Free.
Hendon Motor Co., 48, Vivian Ave., Hendon Central, N.W.4 (not far from Hendon Central Underground).	Demonstrations daily from 3-4 p.m., and by appointment only from 9-10 p.m.
A. Imhof, Ltd., 112, New Oxford St., W.C.1.	Free.
H. Jenks, Ltd., 54, Ebury St., S.W.1.	Free.
Murdoch, Murdoch & Co., 463, Oxford St., W.1.	Free, by invitation.
E. Rogers & Sons, Ltd., 56, 58 & 64, High St., Weybridge.	Free.
Royal Arsenal Co-operative Society, Ltd., various branches in S. London.	Free.
Selfridge & Co., Ltd., Oxford St., W.1.	Free. Appointments have to be booked.
The Teleradio Co., 157, Fore St., N.18.	Free. Names have to be left in advance at various branches of the Teleradio Company.
Thomas Wallis & Co., Ltd., Holborn Circus, E.C.1.	Free.
Wm. Whiteley, Queen's Rd., Bayswater, W.2.	Free.

POINTS OF IMPORTANCE
in the Rola
G.12

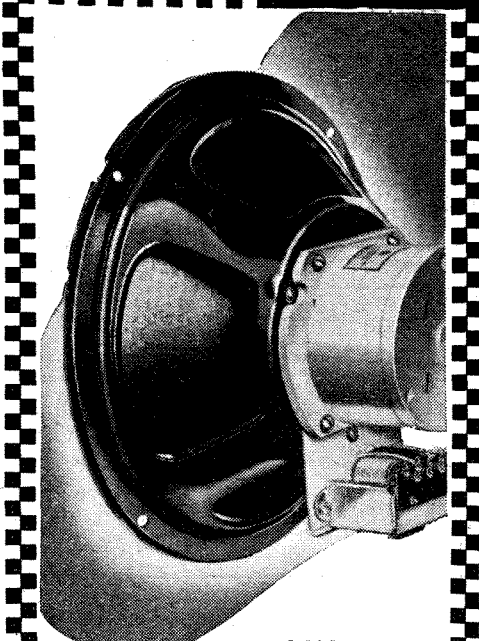

LIKE THE HALL MARK ON SILVER

Just as a hall mark is irrefutable evidence of the quality of a piece of silver, so the use of a Rola G.12 speaker provides unquestionable proof of the quality of a radio receiver. Manufacturers have found that the G.12 is too good to waste on an indifferent set. There is no receiver made to which it cannot do full justice . . . bringing out the best that the set can give . . . providing faithful, brilliant, realistic reproduction. Manufacturers' records show that it is the sets with the G.12 speakers that have shown the greatest increase in sales this year. Be guided by their experience. If you are a manufacturer install G.12s in all models where the outlay is justified . . . if you are a listener see that your set is G.12 equipped.

G.12 P.M. (as illustrated) with Transformer	£5 5 0
G.12 P.M. less Transformer	£4 16 0
G.12 D.C. Complete with Transformer, Mounting Stand, Handle and Base	£5 5 0
G.12 D.C. with Mounting Stand, Handle and Base, but without Transformer	£4 16 0
G.12 D.C. Stripped, but with Transformer	£4 4 0
G.12 D.C. Stripped and without Transformer	£3 15 0

(When ordering please state Field Resistance and Impedance of Transformer required.)

For Public Address work both the P.M. and Energised Models can be supplied with a 15 ohm Voice Coil at an additional charge of 3/-.
Write for Folder A.

OVER 7 MILLION IN USE

ROLA

The World's Finest Reproducers

THE BRITISH ROLA CO., LTD.
MINERVA ROAD, PARK ROYAL, N.W.10.
PHONE: WILLESDEN 4322-3-4-5-6.

Brief descriptions of the more interesting radio devices and improvements issued as patents will be included in this section.

Recent Inventions

IMPULSE GENERATORS

THE two valves V, V₁ are mutually cross-coupled, to form the so-called multi-vibrator circuit (Fig. 1). The anode of V is coupled through the condenser C to the grid of V₁, whilst the anode of the latter is similarly coupled through the condenser C₁ to the grid of the first valve. A circuit of this kind produces oscillations

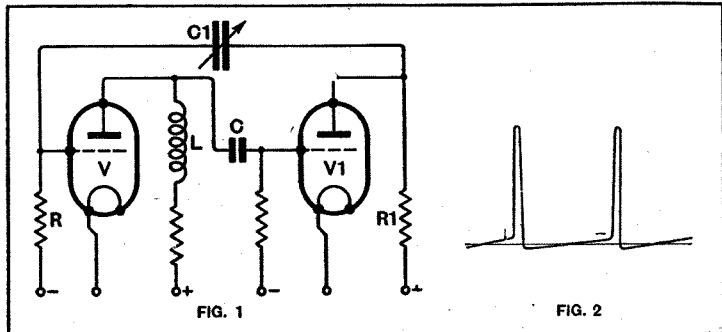

Circuit of multi-vibrator is shown in Fig. 1, while Fig. 2 indicates the form of wave generated.

which are very rich in harmonics, the frequency and wave-form of the fundamental being largely determined by the values of the coupling condensers and resistances.

According to the invention an inductance coil L is included in the anode circuit of the valve V for the purpose of increasing the frequency, and reducing the width of the impulses generated by the valve-combination, so that they take the form shown in Fig. 2.

Marconi's Wireless Telegraph Co., Ltd., and G. M. Wright. Application date February 25th, 1935. No. 452583.

SUPPRESSING LOCAL INTERFERENCE

ONE method of cutting-out local interference consists in using an auxiliary valve, which is normally quiescent, but which is "triggered" by the impact of a strong interfering impulse, so as to produce a biasing-voltage which paralyses, say, one of the IF circuits and so prevents either the signal or the interference from reaching the loud speaker. If the duration of cut-out is sufficiently short, there is no apparent discontinuity in the received programme, though the impulse of static is effectively removed. It is found, however, that the sudden interruption of the carrier wave affects the operation of the rectifier valve and gives rise to a "click" in the loud speaker.

In order to prevent this residual effect, the carrier wave is first removed in the early stages of the receiver (or the signal may be transmitted with the carrier-wave suppressed) and the "interruption" necessary to eliminate local

"static" is then effected at a point in the receiver preceding that at which the carrier wave is again restored. This secures the desired result without giving rise to undesirable noises in the speaker.

N. V. Philips Gloeilampenfabrieken. Convention date (Germany) May 14th, 1935. No. 452107.

DIRECTION-FINDERS

ALTHOUGH the point of minimum or "zero" signal-strength is more sharply defined than that of maximum signal-strength, there are times, for instance on an aeroplane in flight, when, owing to the prevailing

noise, it is necessary to employ the less sensitive method.

In order to do so, and at the same time secure a high degree of sensitivity, the receiving aerial—or its line of maximum response—is caused to rotate through a small but fixed angle. Any departure from the true bearing-line then becomes obvious unless the axis of rotation is truly in line with the distant transmitter. In the latter case, the superposed rotation will produce no variation in the strength of the received signal.

Telefunken Ges. für Drahtlose Telegraphie m.b.H. Convention date (Germany) January 27th, 1934. No. 450484.

VARIABLE-MU VALVES

ONE well-known way of securing a variable-mu effect is to wind the control grid of a valve in an uneven spiral, so that the spacing between successive turns gradually increases. This, however, leads to undesirable results when the control grid is followed by other grids, as in a pentode or other multi-grid valve, because the subsequent grids, being wound evenly, are "clogged" by the irregularities in the electron stream introduced by the first grid.

According to the invention, as applied to a variable-mu pentode, the control grid and the suppressor grid are both wound with the same degree of unevenness; whilst the intervening or screening grid is wound with a uniform spiral, as usual.

N. V. Philips Gloeilampenfabrieken. Convention date (Holland) December 12th, 1934. No. 452541.

TUNING INDICATORS

A CARRIAGE runs on wheels along a grooved track so as to move a pointer along an indicator scale marked with wavelengths or stations. In order to allow of fine and coarse adjustment, the drive is applied to the carriage through either a large or small wheel which makes frictional contact with the surface of the track. Normally the tuning is "fine," but by pressing a release knob, the first driving-wheel is disengaged, and the second wheel is brought into action to move the pointer rapidly over the scale.

The General Electric Co., Ltd., S. G. Hunter, and W. H. Peters. Application date March 5th, 1935. No. 453146.

MODULATING SYSTEMS

IN a magnetron valve the passage of the electrons from filament to anode is controlled by a strong magnetic field applied from a coil wound outside the bulb. This type of valve is particularly suitable for short-wave working, but when used for transmission is subject to certain limitations which tend to reduce its efficiency as a modulator.

In order to remedy this, the signalling voltage is applied simultaneously to the anodes and to a control grid. As shown in the figure, the magnetron is of the split-anode type, the two pairs of anodes A₁ and A₂, A₃ respectively, being interconnected. Modulating signals from the micro-

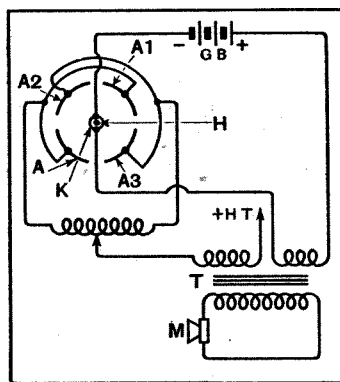

Method of applying modulation to a magnetron generator.

phone M are applied across the transformer T to two windings, one of which varies the voltage on the two pairs of anodes, whilst the other varies, in opposite phase, the biasing voltage on a grid H. The latter takes the form of a straight wire placed inside the helically wound cathode K.

Telefunken Ges. für drahtlose Telegraphie m.b.H. Convention date (Germany) November 30th, 1934. No. 452960.

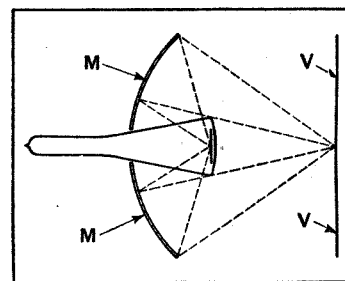

Method of projecting the image in a cathode-ray tube.

TELEVISION RECEIVERS

ONE drawback of the cathode-ray tube when used as a television receiver lies in the fact that the size of the picture is, necessarily, restricted by the overall size of the glass bulb in which the fluorescent screen is mounted. The inventors set themselves to solve this problem by using a reflecting mirror, instead of the more usual magnifying lens.

As shown in the figure, the mirror M is mounted at the back of the cathode-ray tube, which projects through an aperture in its centre. A relatively small tube may be used in this way to give a clear final picture, say, 12 or 18 inches square. The dotted lines show how the light from one particular scanning spot is reflected from all points on the mirror back to a single point on the viewing screen V. Because the fluorescent light is picked up from a wide angle, there is a very little loss. In addition, the back of the fluorescent screen may be made opaque, to prevent any loss in that direction.

Marconi's Wireless Telegraph Co., Ltd., H. M. Dowsett, and R. Cadzow. Application date January 16th, 1935. No. 452148.

CATHODE-RAY TUBE

THE electron stream is focused by two tubular electrodes which are mounted coaxially, end to end, inside the glass bulb, and are maintained at different positive potentials relative to the cathode. A diaphragm with a central aperture is mounted between the ends of the two tubes.

The arrangement is such that of the two electron-optical lenses so formed, the "collecting" lens is predominant if the diaphragm is connected to the electrode carrying the higher positive potential, whilst the "dispersing" lens prevails if the diaphragm is connected to the lower-potential electrode. The diameter of the centre hole in the diaphragm determines the effective "aperture" of the electron lens-system. The use of the two lenses allows a sharper and smaller image-point to be formed on the fluorescent screen of the tube.

Radio Akt. D. S. Loewe. Convention date (Germany) December 9th, 1933. No. 453223.

The British abstracts published here are prepared, with the permission of the Controller of H.M. Stationery Office, from Specifications obtainable at the Patent Office, 25, Southampton Buildings, London, W.C.2, price 1/- each. A selection of patents issued in U.S.A. is also included.

The Wireless World

THE
PRACTICAL RADIO
JOURNAL
26th Year of Publication

No. 902.

FRIDAY, DECEMBER 11TH, 1936

VOL. XXXIX.

No. 24.

Proprietors : ILIFFE & SONS LTD.

Editor :
HUGH S. POCOCK.

Editorial,
Advertising and Publishing Offices :
DORSET HOUSE, STAMFORD STREET,
LONDON, S.E.1.

Telephone: Waterloo 3333 (50 lines).
Telegrams: "Ethaworld, Sedist, London."

COVENTRY: Hertford Street.

Telegrams: "Autocar, Coventry." Telephone: 5210 Coventry.

BIRMINGHAM:

Guildhall Buildings, Navigation Street, 2.
Telegrams: "Autopress, Birmingham." Telephone: 2971 Midland (4 lines).

MANCHESTER: 260, Deansgate, 3.

Telegrams: "Iliffe, Manchester." Telephone: Blackfriars 4412 (4 lines).

GLASGOW: 26B, Renfield Street, C.2.

Telegrams: "Iliffe, Glasgow." Telephone: Central 4857.

PUBLISHED WEEKLY. ENTERED AS SECOND CLASS MATTER AT NEW YORK, N.Y.

Subscription Rates:

Home, £1 1s. 8d.; Canada, £1 1s. 8d.; other countries, £1 3s. 10d. per annum.

As many of the circuits and apparatus described in these pages are covered by patents, readers are advised, before making use of them, to satisfy themselves that they would not be infringing patents.

CONTENTS

	Page
Editorial Comment	609
Morse Practice Set. . . .	610
A New Set for Christmas ..	613
Those Extras	614
Current Topics	616
Home Broadcasting	617
How the B.B.C. Puts the Clock Back	619
Unbiased	620
Broadcast Brevities	622
Christmas Wireless Fare. . .	623
Listeners' Guide for the Week ..	624
Readers' Problems	626
Ready for the Holidays	627
Random Radiations	628
The Simplest Mains Set. . . .	629
Interference from Television ..	630
How to Make your own Records ..	632
Recent Inventions.	634



A Wireless Christmas Presents Which Will Please

TO all our readers, both at home and abroad, we take this opportunity of conveying our sincerest good wishes for Christmas and the New Year. It may seem early to some to speak of Christmas, but it must be remembered that many of our readers in distant parts of the world will not receive their copies for a week or two, whilst some copies may not even reach their destination before the New Year.

At this date, a week or two before Christmas, many of our readers will be concerned with the question of what to give as Christmas gifts, and we would like them to have this timely reminder to help make this a wireless Christmas and, if possible, give wireless sets or accessories as presents. Wireless provides an ideal Christmas gift because there can surely be no other article which is of such general appeal in the home, and more than any other gift, can therefore be given as a joint present instead of dividing up the funds available to provide several individual presents of less appeal.

We need not dismiss the idea of giving wireless just because there is one already in the house, because the public is now beginning to appreciate the advantage of having sets in different rooms, or alternatively, arranging for extension loud speakers from the main set.

Elsewhere in this issue we include articles putting forward suggestions on the choice of sets and accessories, and some ideas are also given for Christmas entertainment.

Some advance details of B.B.C. plans for programmes over the festive season are included, whilst it should

be remembered that all over the Continent Christmas will be celebrated by means of broadcasting, whilst short-wave receivers will this year bring us more into contact with the American Continent than has ever been possible before.

Television Programmes

A B.B.C. Dilemma

FOR weeks we urged that when the television service started facilities should be arranged throughout the service area of the station, so that the public could have ample opportunity for witnessing demonstrations. We felt that the sale of sets could not be expected to begin until the public knew what they were to expect by way of programmes.

But what is the position to-day? Demonstrations are available in almost every district, but wherever we go we find enthusiasm greater before than after a demonstration. Frankly, the public is disappointed with the fare which the B.B.C. is providing, and is unlikely to take much interest in television until an improvement is made.

We are not intending to throw the blame on the B.B.C. Their task, with limited funds, is an almost impossible one if they continue to attempt to make a sort of cinema show through the television medium. We believe the public would be interested, at this stage, to see what is happening in the normal B.B.C. studios during the regular broadcasts. Here the material is already available, and it certainly could seldom be less appealing than much of the present television matter.

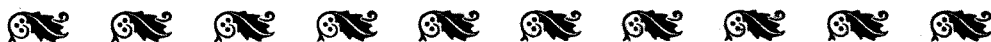

Morse Practice Set

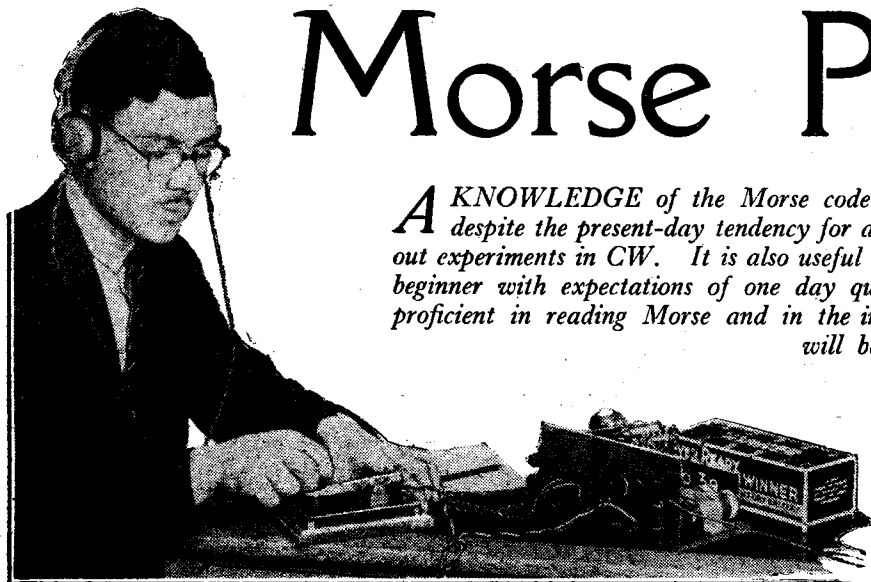

A KNOWLEDGE of the Morse code will give added interest to short-wave listening for, despite the present-day tendency for amateur transmitters to use telephony, many still carry out experiments in CW. It is also useful to be able to identify stations by their call signs. The beginner with expectations of one day qualifying for a transmitting licence, must first become proficient in reading Morse and in the initial stages a simple practice set as described here will be found very useful.

IT is sometimes said that there is an age limit for the learning of the Morse code, but there is no more truth in this than there is in the statement that only the young can take up wireless as a pastime. Learning Morse is mainly a matter for concentration and practice, regular practice being the all-important part, for spasmodic interest in the matter will never lead to proficiency.

Once the code has been mastered to the extent that messages can be read with comparative ease, constant practice is no longer necessary, and even after a lapse of many years the ability to read Morse is not lost and the earlier proficiency is soon regained with a little practice.

The simplest device that will give an audible note is a buzzer, but in order to reproduce as near as possible the style of note that will be heard in the headphones when receiving cw signals by the heterodyne method, one of the high-note type buzzers is needed, and these are not easy to adjust so that they function every time the sending key is depressed.

The alternative is a valve oscillator giving an audible note of about 1,000 c/s. This may be thought to be a complicated and expensive piece of apparatus

possible to utilise old discarded radio components for its construction.

The circuit of an AF oscillator using a low inductance choke, such as the Varley 3-henry model which has several tapings, is shown in Fig. 1. This choke has tapings marked 0 to 5 inclusive, and if joined in the circuit so that condenser C3 is across 0 and 5 and the HT fed into tapping 3 it will oscillate quite readily.

Any high-resistance volume control can be connected across *one-half* of the winding as shown, and it is advisable to include a series resistance of from 20,000 to 50,000 ohms, R4, in series with the output, as without this the shunting effect of the

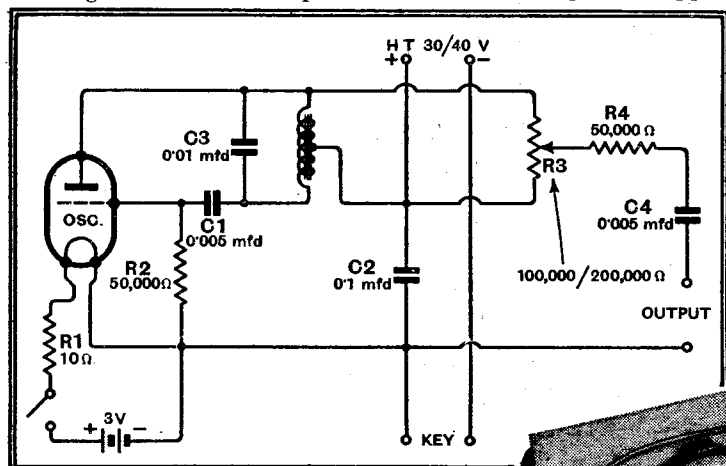

Fig. 1.—Circuit of an AF oscillator using a low-inductance tapped choke.

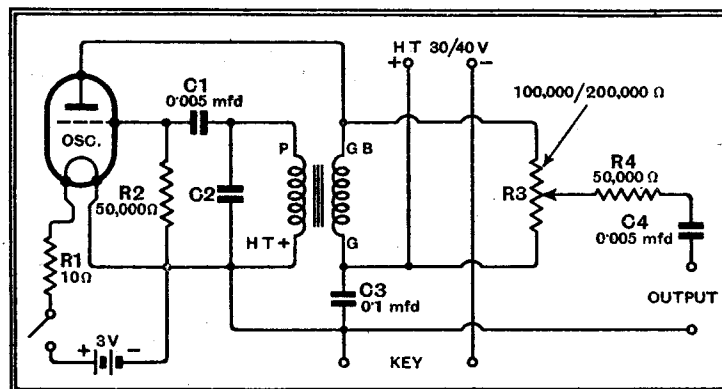
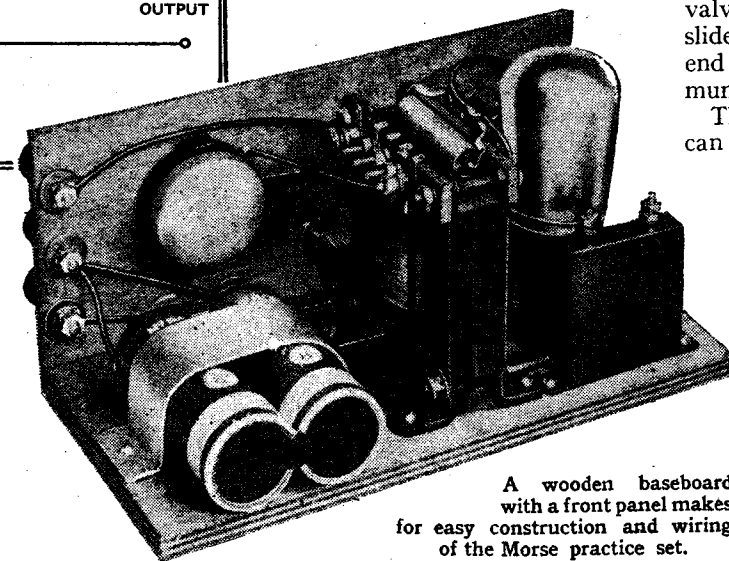

Fig. 2.—An AF transformer can sometimes be used in the construction of an oscillator in the manner shown above.

It is not proposed in this article to deal with the actual learning of the code, as this matter was treated very fully and in a thoroughly sound manner by Austin Forsyth (G6FO) in an article "On Learning Morse," in *The Wireless World* of June 14th, 1935.

The present writer is so firmly convinced that the memorisation of the actual sounds one hears in the headphones or in the loud speaker, as stated in the afore-mentioned article, is the only satisfactory way of learning the code that a few suggestions as to how to produce them may be of some interest to the beginner.



A wooden baseboard with a front panel makes for easy construction and wiring of the Morse practice set.

tus but actually it can be made quite cheaply, especially if one has access to an experimenter's spare parts box, for it is

headphones might stop the valve oscillating when the slider is moved towards the end of R3 that gives maximum output.

The condenser C4, which can be of any value from 0.003 to 1 mfd., is necessary to keep the HT out of the headphones. Any general purpose two-volt valve can be used, though as its LT is taken from a 3-volt dry battery, the Ever Ready Type 800 is well suited for this purpose, it should not consume more than 0.1 amp. of filament current.

A 10-ohm resistance, R1, drops the potential at the filament pins to two volts. Using the values of condensers and re-

SOME CIRCUITS AND SUGGESTIONS FOR BUILDING A VALVE OSCILLATOR UNIT

By G 2 M C

sistances recommended, this oscillator gives out a note of approximately 1,000 c/s, which is a comfortable pitch for Morse code practice.

Fig. 2 is the circuit for an AF oscillator using an old discarded intervalve transformer. Since in this case one is dealing with unknown quantities, for the inductance of the primary winding is not likely to be known, a definite value cannot be given for C₂, the condenser that tunes the circuit. Transformers with high inductance windings are not suitable for this

transformer, the secondary of which has four tappings. The tappings are not essential for the particular purpose mentioned

The title illustrations show a complete Morse practice set for two-way working, and below (Fig. 3) is the circuit diagram with suggested values for the components.

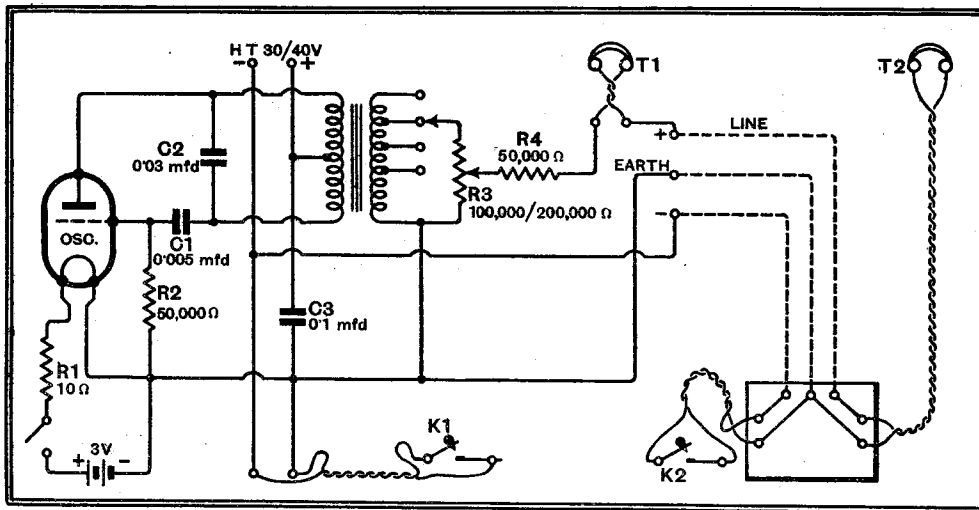
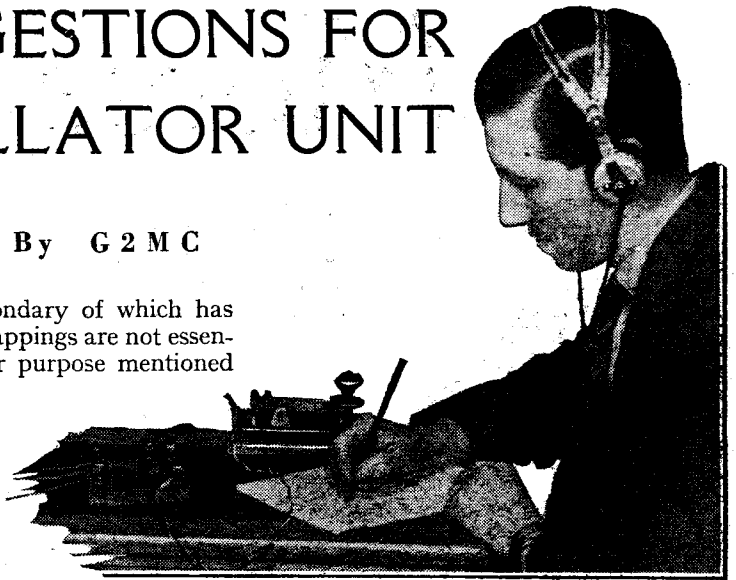

may be made every 300 turns. Forty pairs of stampings are required to give a core $\frac{1}{2}$ in. square. The primary is wound on first, then follows three layers of insulating paper or oiled silk, and over this is wound the secondary. A condenser of 0.03 mfd., C₂, across the primary, tunes it to 1,000 c/s approximately.

This circuit diagram also shows the wiring and connections for a complete Morse code practice set, and allows for sending and receiving from two points without switching. The sender at either end hears in his own headphones the signals sent as well as those received, which is a useful feature as it enables a check to be made on the sending.

A three-wire line joins the two points, and all that is needed at the remote point is a small terminal board wired up as shown at the right hand side of Fig. 3.

The illustrations give a clear idea of the general layout adopted, though in the case of a simple piece of apparatus like this there is no need to slavishly follow the original model, and any scheme best suited to the constructor's needs can be adopted.

purpose, and possibly one of the best would be an old output transformer with a 1 to 1 ratio. This would most likely have a primary winding of about 6 henrys inductance, in which case C₂ will require to be about 0.004 mfd.

To oscillate at the frequency required when a transformer with a primary of 30 henrys inductance is used demands a condenser of only about 0.0008 mfd., and with this small value the oscillator is likely to be somewhat uncertain in its operation, while the frequency will be affected to some extent by the position of the slider on R₃. Should it be necessary to make use of a transformer of this kind, then R₃ could, with advantage, be reduced to about 25,000 ohms, which will help to prevent too violent oscillation and at the same time partly offset the change-of-frequency-effect on varying the volume control R₃.

Construction of the Coil

Of the two arrangements so far discussed, that in Fig. 1 is the better, but if a choke of suitable inductance is not available one can quite easily be made.

For some time the writer has been using a 1,000 c/s oscillator for various purposes that includes a coil arrangement shown in Fig. 3. This is a low-inductance 1 to 1

here, and could quite well be omitted.

The transformer is wound on Stalloy No. 5 stampings, and the primary consists of 1,200 turns of No. 34 DSC wire, though No. 32 enamel could be used if preferred. It has a centre tapping. For the secondary 1,200 turns are used also, and tappings

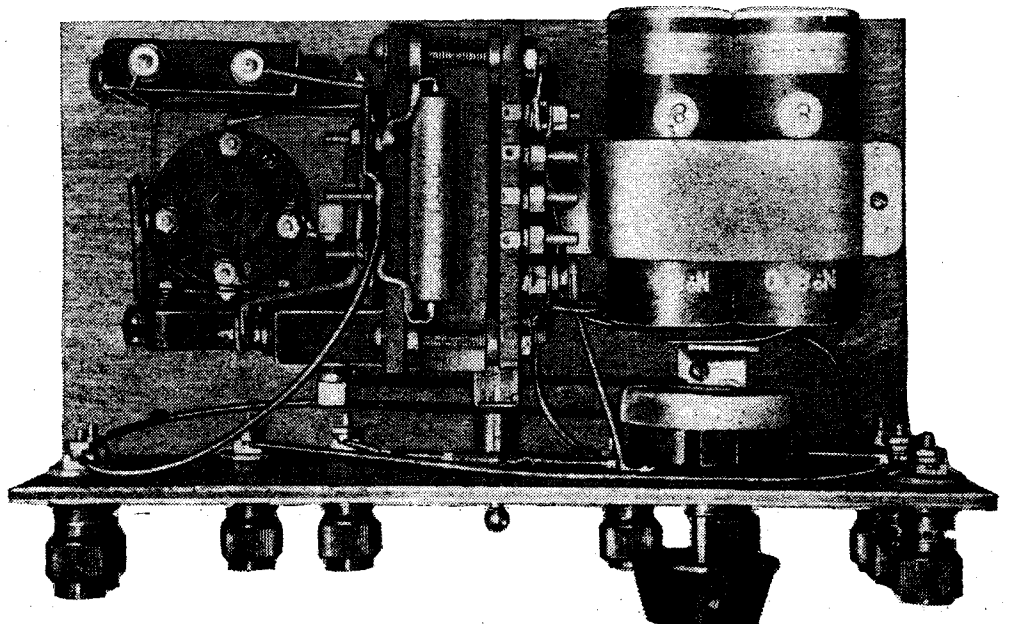

The layout of the components is clearly shown in this plan view of the unit. The volume control, on-off switch and the various terminals are mounted on the panel.

Morse Practice Set—

For the information of those who require it, the baseboard of the model is $\frac{3}{8}$ in. thick and measures 9 x 4 $\frac{1}{2}$ in., while the panel on which is mounted the terminals, on-off switch, and volume control, also measures 9 x 4 $\frac{1}{2}$ in., and is made of 3/16 in. plywood. Though insulated terminals are used throughout, this is a refinement rather than a necessity, and plain terminals not insulated from the wood might quite well be substituted.

In all the oscillator circuits discussed values like the Marconi or Osram HL2, Mullard PM2DX, Mazda HL2 and Hivac D210 can be used with an HT of about 30 to 40 volts. The HT current under oscillating conditions is less than one milliamp so that a 60-volt battery of the smallest standard capacity will last for an indefinite period. All these valves will oscillate quite readily with much less than 2 volts across the filament, so there will be

no need to make any change in the value of R1, for which reason it is not a variable type, though when the filament battery falls to a little below 2 volts R1 can be short-circuited. It must be remembered, however, to remove the short-circuit on R1 when a new filament battery is fitted. This battery, however, will give several months' useful service before a replacement is required.

Running costs are very low, and the oscillator will function reliably and without adjustment for as long as the batteries give an adequate voltage. This depends upon the amount of use it is given plus the hours the valve is left "on" by omitting to switch it off at the end of each session. Though in this case only the filament battery suffers. It might thus be a good idea to wire in parallel with the filament of the valve a low-consumption indicator lamp, but the extra drain will, of course, shorten the life of the dry cells.

On the Short Waves

IT is most interesting to compare the status of the amateur transmitting enthusiast in this country and in the U.S.A., more especially at a time when his very existence, at least on the lower frequency bands, is likely to be questioned by the forthcoming Cairo conference.

In this country the amateurs form a relatively small percentage of the total population, and therefore their power and prestige are similarly small. It is another story in the U.S.A., however, where the percentage is very much higher, and where, efficiently organised by the American Radio Relay League, they are even able to bring strong political pressure to bear.

In fact, at several world conferences the delegates of the A.R.R.L. have been known to have available better secretarial amenities and hotel accommodation than the official representatives of some governmental bodies.

Another point of difference lies in the relative freedom permitted in the U.S.A. to the amateur, who has very little difficulty in obtaining permission to use powers up to 3 kW if he can show that he is a competent experimenter.

Throughout Great Britain the maximum power normally allowed is 0.25 kW, but only in very exceptional circumstances is a licence for power in excess of 50 watts granted. Our U.S. cousins start at 1,000 watts!

The net result of the situation in America has been to turn the amateur experimenters, who number not a few clever engineers in their ranks, into a vast radio research laboratory on a national scale, which, in times of emergency, becomes an accepted channel of inter-communication between town and town, and state and state, supplementing harassed or temporarily broken-down commercial services.

That is the effect as far as the U.S.A. is concerned, but what about this country? Well, one has only to study the advertisement columns of the technical journals to see that the British amateur is rapidly becoming Americanised. He buys U.S. "tubes," they are much cheaper than their home equivalents, and perform at least as

EXTRACTS FROM A LISTENERS LOG

well; he often uses U.S. "communication" receivers. If you want to buy an English "ham" receiver you will find it very difficult.

Dealing with the question of transmitting valves in detail, we find that, quite apart from the very general use of standard U.S. receiving valves over here, there is now, with the more general use of 50 watts on 28 and 56 Mc/s., a marked tendency to import the new high efficiency power triodes and pentodes especially designed for operation on these high frequencies.

In America, the great demand of the amateur has made mass production of even large valves an economic possibility, and one may now obtain excellent high-power valves at prices little above that of an ordinary receiving valve!

It would be no exaggeration to say that the whole of the American radio industry benefits from this spearhead of development, the U.S. amateur being quick to see and utilise new developments and inventions.

It seems a great pity that the amateur in this country cannot play so full a part as his American cousin, and although this is by no means all his own fault, I cannot sometimes help feeling (as an amateur transmitter myself since 1924) that it would not be so bad, after all, if we did lose the bands below 28 Mc/s., provided the maximum power were raised to 1 kW. I should like to receive correspondence on this subject from those interested.

The high spot of the past fortnight, as far as propagation conditions are concerned, has been the appearance of several large groups of sunspots visible to the naked eye, and reported in the popular Press.

It is a little too early yet fully to gauge what the effect of this solar activity has been, but up to Saturday signals from the U.S. improved on all frequencies up to 18 Mc/s, but, strangely enough, the ultra-highs, including W2XE on 21 Mc/s weakened or

disappeared. However, on Wednesday, December 2nd, W9XAZ on 27 Mc/s was an excellent signal round about 6.30 p.m.

It is rather difficult to interpret these results, and it may be that daylight propagation is solely by the "E" region during these periods.

Dealing with the fortnight in detail we find on Saturday, November 21st, W9XAZ Milwaukee good on 27 Mc/s at 6.30 p.m., W2XAD excellent, and even W2XAF good also, a very good night for all signals from the U.S.

Conditions did not seem to be quite so good on Sunday, November 22nd, but TFJ Reykjavik was excellent at 6.40 p.m. near 12.5 Mc/s.

Schenectady W2XAF was again surprisingly good on 9.53 Mc/s at 7.30 p.m.—perhaps even better than W2XAD at this time, but conditions became definitely poorer later on all frequencies.

On Tuesday evening, however, the optimum frequencies had definitely increased; W2XAF was the best U.S. signal at 10.15 p.m., at which time the optimum frequency was 10-13 Mc/s.

In my log for Wednesday, November 25th, I wrote "ionisation must be up—very low noise—best U.S. signal at 10 p.m. being W8XX on 15.21 Mc/s!"

This was the day on which the several large groups of spots appeared, although owing to cloud they were not observed until Friday.

On Saturday the performance of NSS on 32 Mc/s, a steady R8 signal at 6 p.m., and the fine performance of some of the 28 Mc/s amateurs indicated that good conditions had set in, and the poor results on Sunday and Monday, November 29th and 30th, were therefore all the more disappointing.

Excellent results from W2XAD on Monday, however, compensated for other failures.

Wednesday evening provided the surprise, however, at 6.30 p.m. W9XAZ good on 27 Mc/s (11 m.), and at midnight best signal from U.S. was WOO Ocean Gate calling the "Queen Mary" at R9 on 4.75 Mc/s (63.12 m.), which goes to show the rapid change of ionisation levels after sunset.

ETHACOMBER.

The Radio Industry

WORK is to commence immediately on the erection of another big factory block at Mitcham for Philips Radio. The new extension, the fourth to be made in the past four years, has been necessitated by the increased demand for Philips radio receivers; it will have a floor area of approximately 60,000 sq. ft., and when completed will give employment to an additional 800 to 1,000 workers. The factory already employs 3,500 people.

M.R. Supplies, of 11, New Oxford Street, London, W.C., ask us to point out that the initials "M.R." are those of Mr. M. Rogers, who has been well known in the radio industry for the past twelve years. There appears to have been some confusion as to the meaning of these initials, and Mr. Rogers is anxious to remedy this. M.R. Supplies is an entirely independent concern and has no connection elsewhere.

We have received from the Institute of Practical Engineering, First Avenue House, High Holborn, London, W.C.1, a brochure containing the syllabus of a course in broadcast radio technique that is being conducted by the Institute. Instruction is given by correspondence.

A New Set for Christmas

MANY attempts have been made, in these pages and elsewhere, to give helpful advice to those who are faced with the pleasant task of choosing a new receiver. But it is seldom that an effort is made to give a simple answer to the very natural question: "What kinds of sets are to be had?" Subdivision into classes is bound to help the chooser by narrowing down the field of search, but the trouble is that there is hardly any end to the number of classes into which the vast number of commercially available sets may be divided. It is therefore proposed to take the drastic and admittedly somewhat arbitrary step of boiling down broadcast receivers into three main classes:—

- (a) **Sets of the standardised domestic type, assembled as single units and which satisfy average requirements; an output of some three watts is roughly the maximum.**
- (b) **High-quality sets with a large output (at least 4 watts) and with a radio-frequency section designed either for all-round long-range reception or mainly for local-station work.**
- (c) **Special-purpose sets—portable, short-wave and the like—including specialised non-domestic sets (e.g., for cars) which need not be discussed here.**

It should be made clear that the lines of demarcation between these classes are not sharply defined. For instance, some of the mass-produced sets tend to encroach into the specialised "quality" field (the more credit to their designers that they do so) while few of the special-purpose sets are quite satisfactory for domestic reception of broadcasting. With all its imperfections, however, the arbitrary classification suggested above will serve as a basis on which to discuss the various types that fall into each of the classes.

Standard Broadcast Sets

Class (a) is, of course, by far the largest, and most of the types in it are produced in forms suitable for battery, AC or universal AC/DC use. The matter of power supply being automatically settled for us, the first question to be investigated is that of wave-range. That, however, is largely a matter of personal taste; the provision of one or two short wavebands does unquestionably add considerably to the "interest value" of a receiver, and to judge by experience of recent all-wave models, does not (contrary to fears expressed at the beginning of the present wireless season) add appreciably to the risk of breakdowns. On the other hand, those who do not want the "all-wave" feature have the satisfaction of knowing that, all other things being equal, they should save a pound or so by

NARROWING DOWN THE FIELD OF SEARCH

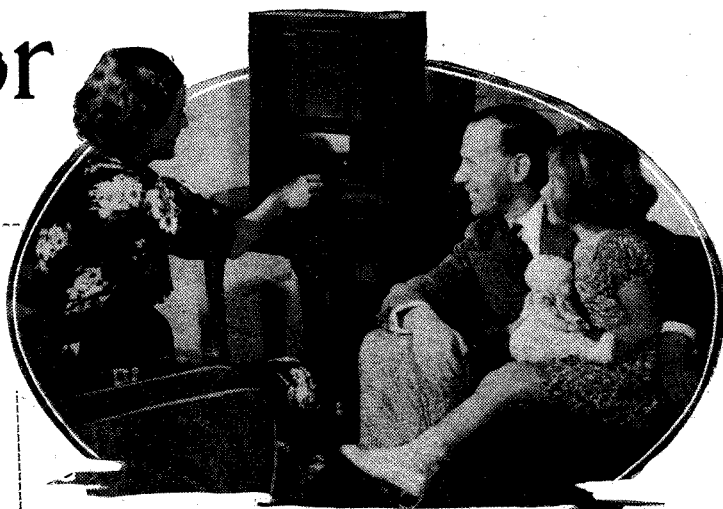

plumping for a normal two-waveband set.

The question of "straight" or superheterodyne is a good deal simpler than it used to be, and now resolves itself largely into a matter of cost. With practically no exception, so far as the low- and medium-priced fields are concerned, all sets with any pretensions to range and selectivity are superheterodynes and practically all prejudices against the system of reception embodied in them have been satisfactorily disposed of. The straight-forward tuned-RF 3-valve set, costing 7 or 8 guineas, is perfectly satisfactory for local-station work, with occasional foreign excursions when conditions are good, and for about a guinea extra one can obtain a similar model with provision for short-wave reception.

When long-range reception is desired, the TRF set cannot compete with the superhet on the basis of cost; that is the reason why the superhet has become virtually the standard British receiver. Two-band superheterodynes now cost between 10 and 16 guineas, one or two guineas extra being charged for the comparable all-wave versions; it should be pointed out that prices given in this article are approximate, as there are a few models outside the limits given, and also that they relate to table sets. Upright consoles are some 2 or 3 guineas dearer, while the extra cost of a radio-gramophone is seldom less than 10 guineas, depending on the cabinet work and record-playing accessories, etc.

This seems an appropriate place for mention of the value-for-money question which, like other problems, is easier than it used to be. A rough-and-ready basis for comparison can easily be arrived at by taking into account the number of valve stages, number of tuned circuits and output power, with an allowance for workmanship and—last but not least—the reputation of the manufacturer and the existence of service facilities. As an example, it will generally be found that the more costly all-wave superheterodynes (15-18 gns.) have an RF stage and a second short waveband that are lacking in the cheaper 12-guinea models.

Among the "quality" sets (Class (b) in our arbitrary classification) we find

models designed primarily for those who insist on an exceptional standard of reproduction; in some cases an equally exceptional radio-frequency section is fitted, but many quality enthusiasts are satisfied with a medium-range tuning system. Many of the sets are in radio-gramophone form, but some makers adopt a more flexible system of construction whereby various circuit combinations and units may be assembled to suit the requirements of the user. For instance, a separate loud speaker may be employed. The cost of quality equipment of the kind now in mind runs from some 25 guineas upwards.

Auxiliary Receivers

So far as Christmas-time requirements are concerned, interest in the specialised receiver field centres on the miniature portables, of which the principal use is as a sort of "personal" receiver for use at times and places where the domestic set is not available. They make extremely attractive presents—for oneself or anyone else—and their price is from 5 guineas upwards. The kind of set under discussion at the moment is of the truly portable type, weighing about 10-15lb.

There are, of course, a number of self-contained sets weighing something in the neighbourhood of 30lb., and which are rather too bulky for convenient transport, although they can be readily moved from room to room. These larger sets have the advantage, as compared with the miniatures, of giving much better quality and generally much longer range. Many, indeed, embody a highly sensitive circuit, and thanks partly to the directional properties of the frame, have exceptionally good interference-eliminating properties. Still another type of set that may be considered as an auxiliary is the mains-driven transportable.

Specialised short-wave sets are coming on to the market in increasing numbers, and for the real enthusiast, present attractions that are unrivalled by those of anything except perhaps the one or two "communications" type sets that are available. In the design of all sets of this type there is less compromise than in apparatus designed wholly or partly for the requirements of domestic broadcasting.

Those Extras

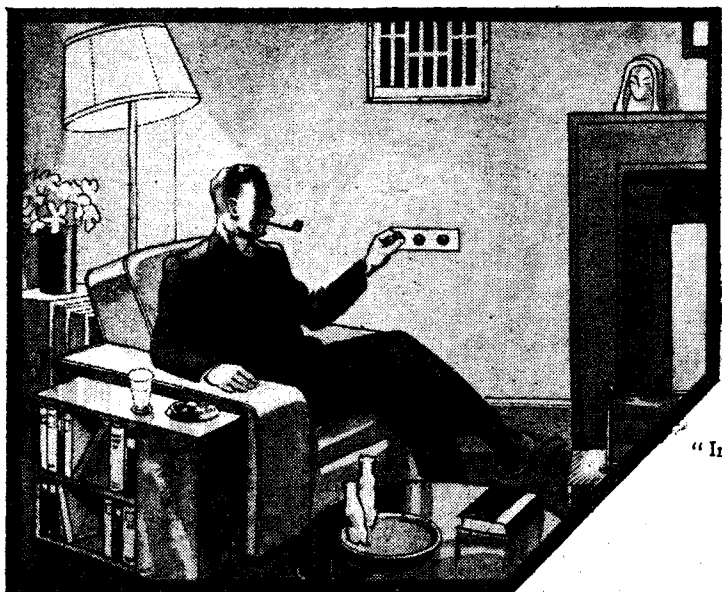

By
"CATHODE
RAY"

"In years to come."

room—a very exceptional state of affairs, surely—the worst position for tuning-in is right up against the speaker.

That, however, may be considered a fine point or perhaps a matter of opinion. But there must be very few households in which it is not convenient to listen quite often in a room other than the one where the receiver is installed. There are portables, of course, but how many people use them in preference to a good fixed set? It may not be considered financially practicable, or worth while, to provide loud speakers all over the place; but the cost

RADIO enthusiasts, like Alexander the Great, look around for more worlds to conquer; but, unlike Alexander the Great, have not enormous means at their disposal. It would be very thrilling to buy or build an absolutely new and exclusive model at intervals not exceeding one year, but few can afford to do so. Whether you can or can't, have you fully considered what can be done to increase your radio facilities at comparatively small cost? There is no compulsion to think in terms of complete sets; there are such things as accessories.

The appeal of these bits and pieces varies a good deal according to temperament. There are those people who are quite content to have a neat, conventional, self-contained receiver standing in the room, precisely as left by the salesman-demonstrator, and who abhor anything that they could possibly describe as a stunt. Such people are not the keenest followers of *The Wireless World*. Personally, I think one can hardly go too far in extending the conveniences and facilities of radio. In years to come, the people who build our houses (as distinct from those who build super-luxury flats for the select few) may wake up to this, and as soon think of omitting extension wiring, built-in aeriols, and interference suppressors as of leaving out main drainage, el. lt., h. & c., and other modern conveniences. In the meantime, residents who are unaware of what can be done, or who lack the effort or initiative to do it for themselves, lose a lot of that to which their ios. licence entitles them.

Separate Speakers

The most valuable and well-known facility is the extension loud speaker. Exigencies of commerce have led to the virtually universal practice of putting receiver controls and loud speaker into one cabinet. Considerations of common sense declare that this is about the only place in which a loud speaker is unsuitable. Even if listening is desired in only one

fully, and consider whether it would not be worth spending a little more in getting at least four-way wire. It is good to have extension loud speakers. But it is vastly better to be able to turn the receiver on and off without going to it. This is particularly so when one is comfortably in bed. There *are* ways of doing remote control over the loud speaker wires, but they tend to complicate things considerably, and the extra cost is likely to do more than pay for extra wires. Three wires can be made to give two complete circuits by using one common to both; but the more wires you have the more things you can do with them. There are possibilities of selecting Nat. and Reg.; and other advantages. I leave you to think about it.

Automatic Time Switches

While one is considering devices to further the spread of laziness (or efficiency, if you prefer that term), the clock that switches the set on and off at predetermined times should not be overlooked. It surprises me that this sort of thing has not been developed to a greater extent, especially, when electric alarm clocks are sold in large numbers at quite low prices, including models that light themselves up during hours of darkness. Apart from any switching devices, the logical place for



On and off,
National or
Regional.

of one, which can be plugged in anywhere, is small in relation to the benefit.

It necessitates extension wiring. If we had no control over the building of the premises, it is highly improbable that such wiring exists. As an afterthought, it often presents awkward problems. One solution—the lazy one—is to use a long trailing flex. But when the speaker has been dragged on to the floor a few times, and some shorts or "disses" have developed, the merits of this method may appear questionable. Inconspicuous and inexpensive wiring systems are on the market, complete with neat sockets and other connectors; and when the worst comes to the worst there is special "tape" flex for laying under carpets.

To many people the only sort of wire for this purpose is twin. Before rushing off and ordering it, think again, very care-

a clock is on or near the radio; a small, uncased unit can be mounted flush on the panel or cabinet and run from the same electric connection as the receiver, but, of course, on the mains side of the receiver switch!

In Emergencies

More than one receiver per house is very highly recommended, particularly by the trade; but it is not everybody who can do that sort of thing. However, there is the humble and rather undeservedly forgotten crystal set. When most of what we read nowadays seems to insist on the extreme probability of war in our midst at any moment, I hate to swell the chorus; but it does seem to me that, if there *were* an emergency resulting in a failure of the power supply, the expense and trouble to

MORE CONVENIENCE AND BETTER FACILITIES: IDEAS FOR CHRISTMAS

which the B.B.C. have gone in making their transmitters independent of the mains would be largely wasted on mains-driven receivers. A little crystal set "keeps going when the rest (even the best batteries) have stopped." And it is economical for individual listening, and people who may not want to hear the programme are glad when phones are used by those who do.

Talking about phones, they are useful things to have about the place in any case. When run from a loud speaker type of set a considerable step-down in power is required (except in extreme cases of deafness), and the simplest way is to use high-resistance phones on the low-resistance speaker output terminals. That brings it about right.

"Cathode Ray's" Ideal R.-G.

Turning to the input end of the receiver there is no need for me to direct attention to what can be done with a pick-up (assuming the instrument is not already of the radio-gramophone description). But the precise disposition of it may leave room for diverging practices. My own idea of the proper place for a pick-up is a small trolley affair that can be wheeled to the side of the armchair. With a volume control mounted on the outside, a couple of shelves or pockets for used and unused records, and a flexible cable to mains and receiver (the latter well screened from the former), you can sit back from the loud speaker in the place that is most comfortable—aurally and physically—and be spared having to jump up every few

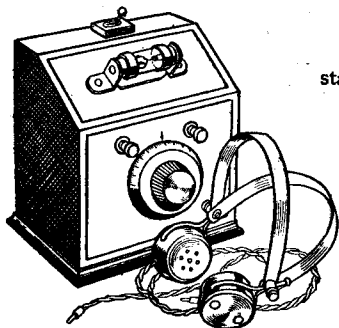

The stand-by.

minutes. Of course, if you don't really listen to records, but only want them to make a cheerful noise for you to do something else to, an automatic record changer is the thing.

A microphone is another item that can be connected to the pick-up terminals.

"Laziness — or efficiency, if you prefer the term."

Except for Christmas parties and sundry practical jokes, there is not much scope in the ordinary home, but owners of multi-watt-producing sets may occasionally be called upon to do things of a more or less public-address description. One's recreation or other club might sometimes be glad of this sort of thing.

All-wave receivers are *de rigueur* just now. Rather than have to be a humiliated back number merely through want of cash, why not investigate the possibilities of short-wave converters? I confess I used to think very little of them, but recent trials have obliged me to modify this opinion. Even if the receiver sen-

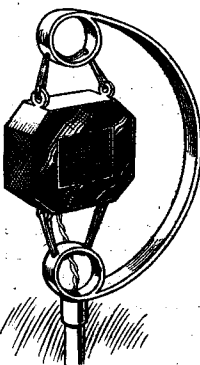

For your own broadcasts.

sitivity on medium and long bands is quite unexciting it is not necessarily unsuitable for use with a converter, because a properly designed one gives a very considerable amount of amplification.

The merits of anti-interference and other special types of aeriels have been heralded by louder and clearer trumpets than mine, so I merely mention them for the sake of completeness. After about fifteen years during which aerial design has progressed backwardly if at all, there is considerable evidence that it is now being taken really seriously. The results of this work are appearing on the market. Besides those offering reduction in interference, with usually a slight inevitable loss in signal strength (but well worth it where interference is bad), there are aeriels designed to give a step-up in signal strength over certain wavelengths. This applies especially to television waves, but the ordinary short-wave broadcasting bands can also be received better with special aeriels.

There are other accessories, which may not add anything very startling to the versatility of the installation, but which add

to the efficiency of maintenance; a small milliammeter on the panel, for example, to show up such things as waning batteries, failing valves, half-waving rectifiers, and shorted turns in the power transformer. And fuses of an up-to-date kind, for either mains- or battery-driven systems. And battery chargers where there is a battery set in a mains house. Some connoisseurs stick to battery HT, which is a good deal less troublesome and long-lived if it hasn't to be carted away to be charged.

The addition of some accessory or extension serves its own purpose—to advantage, presumably—but it also gives one something to show to visitors with a degree of pride. *Anybody* can have an ordinary set with a hole and three knobs on the front!

In suggesting ideas for increasing the utility and pleasure of the radio installation I have addressed myself to the supposed needs of you—the reader. But at this time of the year it is appropriate to point out that, even if your house bristles with all that is modern, some of your friends may not be in the same fortunate condition. And you may be racking your brain to think of what to give them. Putting two and two together. . . .!

The Wireless Trader Year Book, 1937. Pp. 132 + 112 diary pages. The Trader Publishing Company, Ltd., Dorset House, Stamford Street, London, S.E.1. Price 5s. 6d. post free (overseas 7s. 6d.), or 3s. 6d. to *Wireless Trader* subscribers.

THE 1937 edition of this valuable work of reference has now appeared; as usual, its circulation is restricted to the wireless and gramophone trades.

The provision of index tabs for the most frequently used reference sections is a useful addition. There are now abridged specifications for nearly 500 broadcast receivers, and characteristics of all valves in common use are given, together with base connections. Manufacturers and distributors' addresses, and sources of supply of apparatus and materials, together with an index of proprietary names, constitute a comprehensive trade directory. Technical, legal and general information is under appropriate headings.

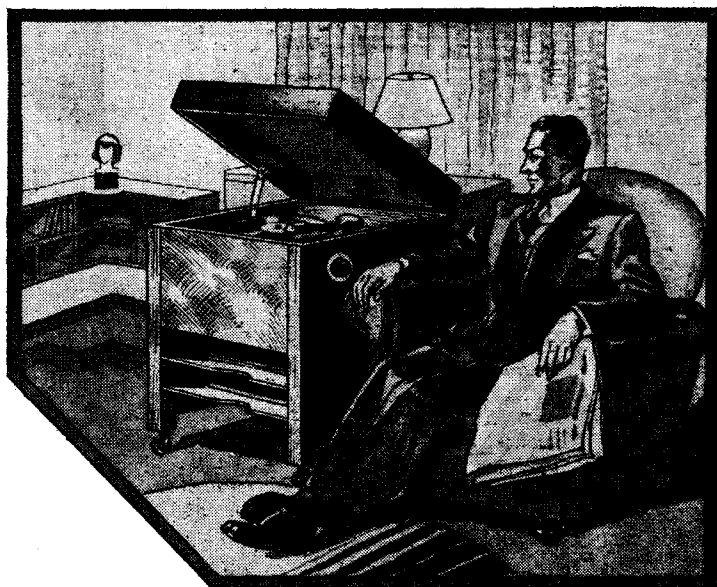

CURRENT TOPICS

EVENTS OF THE WEEK IN BRIEF REVIEW

Five-metre Activity

AMATEUR transmitters in the North-west of England are proposing to establish a chain of low-powered, five-metre stations to link up Manchester, Liverpool and North Wales on Sunday mornings. A special programme of experimental work on this very low wavelength will be carried out.

Police and Fire Brigade Radio

ANATION-WIDE co-ordination of the wireless services of the various police forces and fire brigades of the country is foreshadowed by the appointment of Lt.-Commander K. B. Best, R.N., to the Home Office as Advisor on police and fire brigade communication services. Commander Best was formerly Communications Officer of the Metropolitan Police.

New Stunt for Selling Radiograms

IN addition to broadcast talks on what to do in an air raid the Italian authorities have now issued a series of four gramophone records containing detailed instructions. These records are being sold at an exceptionally low price and all known radiogramophone owners are being pressed to buy them, while those who own receivers only are being made to feel that it would be a patriotic action to invest in a radiogram, or at least a pick-up and turntable, although they are not being sold any cheaper on this account.

Seasoning Wood by Ultra-short Waves

IT has hitherto been impossible to season wood quickly, since attempts at rapid drying by ordinary means results in the interior moisture being imprisoned by the quick drying and hardening of the outer skin of the wood.

A Russian scientist has now, however, made use of radio-diathermy, using a wavelength of between 5 and 6 metres, which has the effect of driving the interior moisture quickly towards the surface of the wood. This process is so rapid and satisfactory that it is said that an oak board 5 centimetres thick, which normally would require four to six weeks' air drying, can be seasoned in half

an hour, and, moreover, there is not the slightest trace of warping.

Television in the Cinema

APRESS demonstration of what may be termed cinema-screen television was given by the Baird Co. at the Dominion Theatre last Sunday. The pictures appeared on a screen 8 ft. x 6 ft. and, despite the fact that only 120 lines were used instead of the 240 employed by the Baird Co. at the Alexandra Palace, were remarkably clear. The transmission was from a studio inside the theatre. It was originally intended to pick up a programme from the Baird experimental station at the Crystal Palace, but unfortunately the recent fire damaged part of the transmitting apparatus.

An Unusual Licensing System

IN the Dutch East Indies, the wireless licence fee is on a sliding scale, the amount varying in inverse proportion to the number of listeners. In this manner the income derived from the sale of licences is maintained at a constant figure. There are at present thirty thousand listeners who are served by twenty-two transmitters. It is noteworthy that sixteen of these transmitters work on wavelengths between 100 and 200 metres in consequence of the very bad atmospheric conditions on any wavelength above 200.

Scandinavian Activities

IN future, foreign artistes who appear before the microphone in any of the Scandinavian countries will receive identical fees, no matter in which country they may appear. This will check the growing tendency for the wealthiest of the Scandinavian countries to obtain the best artistes by outbidding their neighbours. The Norwegian station at Bergen has changed to 235.1 metres, and its former wavelength of 352.9 metres is being used for testing purposes by the new 20-kilowatt station at Stavanger. Later, when the new Bergen transmitter that is being constructed at Frulandsmyren is completed, the wavelength will be increased to 1,186 metres.

German Trade Figures

OUT of 1½ million receivers sold in Germany in 1935, nearly half a million were of the Volksempfänger type. 373,000 of the above-mentioned set purchasers traded their old receivers in part exchange for new ones.

Finnish Amateurs

IN Finland the amateur movement continues to make slow headway, and the number of transmitters is now 232, of which 180 are actually active.

An Interesting Lawsuit

THE appeal of the German gramophone industry to the Supreme Court has resulted in a reversal of the judgment of the two Lower Courts, thus rendering the German broadcasting authorities liable for the payment of a licence fee for each broadcast of a gramophone record. The broadcasting authorities are liable to pay for any record broadcast after April 5th, 1935.

Are Announcers Underpaid?

RUMOURS are frequently heard concerning the large salaries paid to radio artistes in America which seem to be about on a par with those of Hollywood. Similar stories are sometimes heard concerning the pay of announcers, but, according to figures recently published in the U.S.A. as a result of a radio census, these big pay-rolls are apparently only obtained by stars. The average takings of an artiste work out at 41 dollars per week, and the average weekly salary for an an-



Mr. Emil Holm, who has been programme director of Danish broadcasting since it commenced in 1923, recently announced his intention of retiring. In spite of stringent criticisms of the programmes which have been made of late years, his great personal popularity is shown by the flood of subscriptions received by the committee appointed by newspapers and listeners' organisations to provide a tangible mark of esteem on his retirement.

nouncer is 29 dollars. Actually, although artistes and announcers together make up almost one-half of the total number of persons getting a living out of broadcasting, they do not receive the same proportion of the pay-roll. Engineers and other technicians, whose salaries are not stated, seem to account for a greater part of the twenty-one million dollars annual pay-roll than many people suppose. It is interesting to note that there are 561 broadcasting stations in the United States giving regular employment to some 12,000 people.

Fire Damages Destroyer's Aerials

EXTENSIVE damage was caused to the wireless installation of the new destroyer, H.M.S. Hasty, during a recent fire on board.

Television and Astronomy

IN the course of a speech at the recent Television Exhibition held at Strasbourg, Professor Lallemand said that astronomers were watching the development of television with great interest. Television, he pointed out, involved the conversion of light waves into electrical impulses which, after enormous amplification, it was possible to convert into light waves again. Such amplification, he pointed out, was far greater than could be achieved by the telescope using ordinary optical means, although, of course, it would be necessary first to secure the image of a star in a telescope, the eye-piece of which would be directed on to a photo-electric cell.

A Memorable Year

1937 is apparently going to be a year of exhibitions and of National celebrations of one form or another in which radio will play a very prominent part. Apart from many activities over here Denmark is arranging a world-wide broadcast to be given towards the middle of May in celebration of King Christian's jubilee.

On the occasion of the tenth anniversary of Lindbergh's flight between New York and Paris, which occurs during the great Paris Exhibition of 1937, a special air race between the two cities is said to be in the course of being arranged, and already the big broadcasting concerns are said to be preparing for special commentators to accompany the competitors across the Atlantic in specially chartered aircraft.

In the summer of 1937, broadcasting and television are going to be very big features of a large industrial and agricultural exhibition being arranged by the U.S.S.R.

Home Broadcasting

Suggestions for the Use of a Microphone at Christmas and a Brief Description of the Apparatus Required

By H. B. DENT

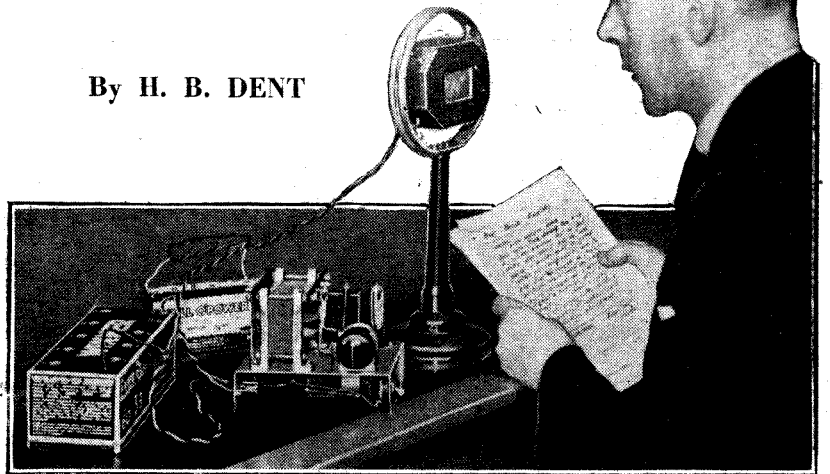

IT is always a difficult matter to devise something novel and out of the ordinary in the form of entertainment at Christmas, but here is a suggestion that might prove of some interest. Radio is still sufficiently a mystery to many people for anything emitted by the loud speaker to be regarded as genuine broadcast matter. Especially is this so in the case of younger members of the family, so that if a microphone is secreted in some part of the house and, at an opportune moment, connected to the gramophone pick-up terminals of a broadcast set, some very amusing and perplexing announcements can be made for the benefit of those present.

Some care is needed in arranging any

THE apparatus illustrated and described here can be acquired at comparatively little cost, yet it offers endless possibilities for entertainment during the Christmas holiday. It is by no means the simplest that could be used, but it is capable of giving reproduction of a very high standard either on speech or music, and is, therefore, well suited for the more serious purposes of home recording.

used on other occasions, one such being in connection with home recording. Those who have been thinking of acquiring a home recording outfit might also bear in mind its possibilities as a medium for entertainment this Christmas, though, of course, the apparatus is not really intended for this purpose, as even the inexpensive units are now capable of giving very good results indeed if a little care is taken in the use and preparation of the equipment.

Though space does not permit treating this matter at greater length, it will no doubt be realised that a microphone is a useful piece of apparatus both for the lighter side of everyday affairs and for the more serious matter of home recording. It behoves us now to give a thought to the technical matters relating to its use.

As an alternative to the circuit on this page, which incidentally shows the minimum of parts needed for the pre-

amplifier, there is the arrangement described in *The Wireless World* of October 16th last. This is ostensibly the same as the circuit shown here, only it has a step-up transformer in the anode circuit of the valve. Slightly more amplification is provided, and at the same time the transformer serves to isolate the unit from the broadcast set. However, this is a minor detail.

With the majority of receivers a unit similar to the one illustrated will give perfectly satisfactory results, though the connections must be made so that the "earthy" pick-up socket is joined to the LT negative, or chassis, of the pre-amplifier.

A battery unit is strongly advised, for if attempts are made to employ a mains

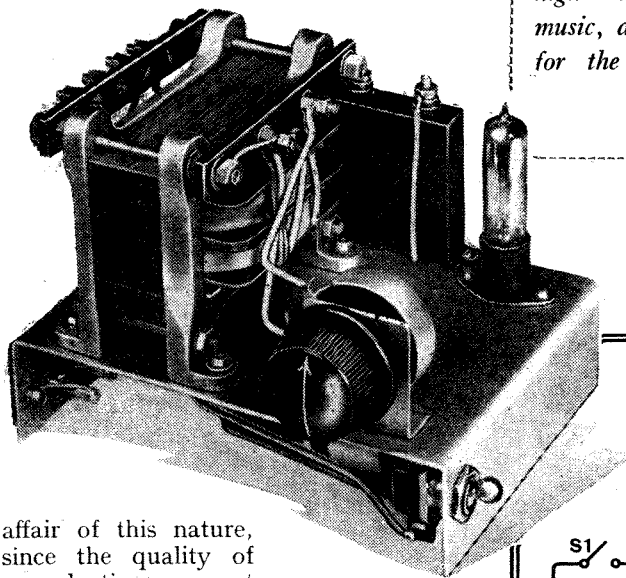

The pre-amplifier is shown on the left and below is the theoretical circuit diagram with suggested values for the components used.

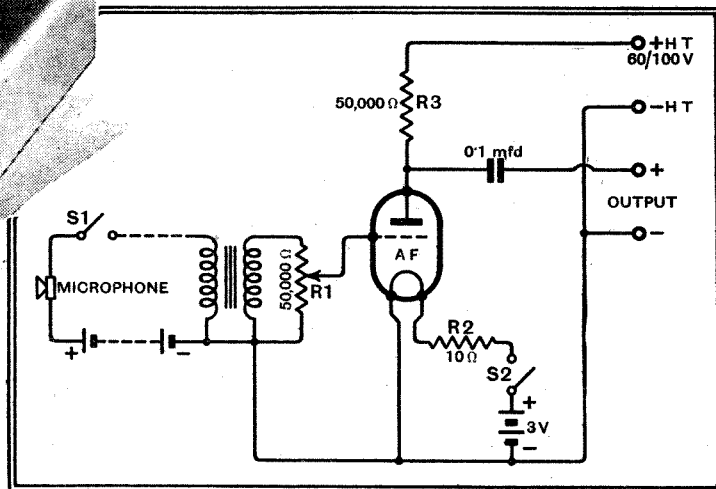

affair of this nature, since the quality of reproduction must bear a reasonably good relation to the genuine article or the deception will be detected immediately.

A good microphone is, therefore, essential, but a transverse-current carbon-type will answer as well as any for the purposes mentioned here, provided it is used with a good microphone transformer, for the quality of the reproduction, even from the best microphone, will be very poor if the transformer is an inferior article.

A microphone of this type gives a comparatively small output and will not function satisfactorily if connected direct to the pick-up terminals of the average broadcast set, so that arrangements must be made to provide some additional amplification. This is best effected between the micro-

phone and the receiver, and a unit for this purpose is usually described as a pre-amplifier.

Its construction is comparatively straightforward, for a simple form of circuit, such as is shown above, will answer the purpose quite well.

This equipment is also capable of being

Home Broadcasting—

valve and take its HT and LT from the broadcast set there is the risk that very bad mains hum may be heard in the loud speaker.

Hum can be due to various causes, but the principal ones are: insufficient smoothing of the HT and direct pick-up by the microphone transformer. If the first is eliminated by using batteries only the last is left and attention can be concentrated in obtaining a silent background by suitably disposing the pre-amplifier.

Cases have been encountered where entire freedom from hum could only be obtained by placing the amplifier some six feet from the receiver and joining the two by screened cable.

Completely screened microphone transformers are less prone to this trouble than the "open" type, but the screening has to be very thorough and the metal of the box has to be at least $\frac{1}{4}$ in. thick to be really efficacious.

Mains hum is not the only disquieting effect that may be produced on adding an

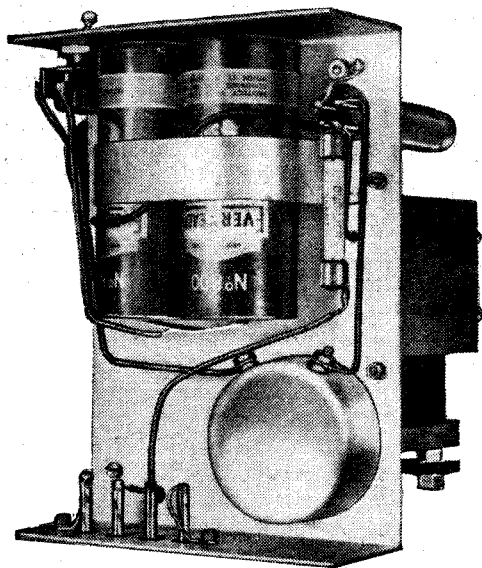

Underside view of the chassis of the pre-amplifier, showing the LT battery and the pre-set variable filament resistance, R2 in the circuit diagram.

extra amplifying stage to the set. When first switched on everything might be quite satisfactory, but after a few minutes the loud speaker begins to emit a howl which gradually builds up into an ear-splitting roar.

This trouble will almost certainly be encountered if the microphone is located in the same room as the loud speaker, but as for most of the effects one may require to produce at Christmas the microphone will have to be secreted in some remote part of the house, this acoustic reaction, or feed-back, trouble will not appear. If howling is encountered it can only be due to a very microphonic valve in the pre-amplifier and the cure is obvious.

When using a home recorder the loud speaker in the receiver ought to be disconnected so as to obtain the maximum power in the cutter. A microphone can then be used in the same room as the set and the recorder with every assurance that

the equipment will function in a perfectly satisfactory manner.

The microphone and its transformer shown in the illustration here are home made, and both have been described fully in *The Wireless World*, the former in the issue of January 11th, 1935, and the latter in that of May 29th, 1936.

A stand for the microphone can easily be improvised, yet made to look quite attractive, by adapting a table lamp stand and fitting a ring suspension to it as shown. This consists of a length of $\frac{3}{4}$ in. brass strip bent to form a hoop and with holes drilled at four places round its circumference. Rubber bands are threaded

through these holes to support the microphone. If enamelled the same colour as the stand it will have quite a professional appearance.

This brief description of the apparatus illustrated here will, it is hoped, serve to show that it does not require anything very elaborate to achieve some amusing effects at Christmas time, nor need the cost be more than quite nominal if the user is prepared to construct the principal items himself.

The equipment is not limited in use for entertainment purposes only, but may also serve for the more serious matter of home recording.

Letters to the Editor

The Editor does not hold himself responsible for the opinions of his correspondents

"Interline" Synchronising

THE letter from Mr. Rudder published in your issue of October 9th, 1936, states that the use of synchronising signals interposed between the line picture signals in television was first suggested in your issue of July 3rd, 1929. The principle was disclosed in Mr. Baird's patent No. 269,834, dated October 21st, 1925. C. R. BANNISTER.

London, S.E.14.

Little Pictures, Loud Noises

YOUR contributor, "Diallist," has raised a debatable point in comparing the sound level of a television receiver with its picture size.

The designers have in mind an audience of three or four per set, and thus a viewing distance of some five or six feet is reasonable. In these circumstances the illusion is exactly the same as that presented by a cinema screen viewed from a good seat. The angles subtended by the 10in. x 8in. picture can be easily compared with those of a cinema screen by observing that the vertical dimension of the television picture is just covered by the breadth of four fingers at arm's length when at the correct viewing distance from the set.

At this distance a sound volume of pleasant proportions is much the same as is found in use on ordinary sound reception with its equivalent illusion.

The usual crowd of fifty or so found in some of the popular demonstration rooms is too large for proper appreciation of a receiver intended for the home, and it is doubtful if more than ten of that audience have a true presentation of the receiver's performance. R. POLLOCK.

Wembley, Middlesex.

Television Costs

MR. EARNSHAW-WALL'S letter in your issue dated November 6th bestirs me to voice the irritation I feel with your amazing attitude to the function of the 10s. wireless licence.

If the B.B.C. expenditure on television leads to a reduction of the quality of ordinary broadcast material, then obviously the listening public will be justified in considering part of its licence money is being used to provide entertainment for a wealthy minority; why quibble about this?

The primary point is (and this is the aspect you should emphasise) that it is probable that television reception will rapidly become cheaper, and in a few years will be within reach of the majority of licence holders; and secondly, the expenditure is not likely to be sufficient to noticeably influence the quality of ordinary broadcast programmes. However, if it were not for the first point mentioned, no expenditure of the licence money on television could be tolerated. B. C. GALLOWAY.

Surbiton, Surrey.

New Air King Receivers

SINCE the publication of our Guide to All-Wave Receivers in the October 30th issue we learn that the G. & C. Distributing Co., 115, Shaftesbury Avenue, London, W.C.2, have in stock a new range of Air King receivers comprising five models each equipped for short-wave reception in addition to the usual broadcast bands.

The leading receiver is the "Empire" Model 507 with two short-wave ranges covering 14 to 51.5 metres and 51.5 to 175 metres. There is an RF amplifier working on all four wave ranges, and the IF amplifier is adjustable to three alternative band widths. Amplification at audio frequencies is in three stages, the last two being resistance-capacity coupled in push-pull, and the output of 15 watts is taken by a 10-inch moving coil in conjunction with a "tweeter." The price is 26 gns., and from the specification an outstanding performance for a table model receiver is to be expected.

Three wavebands, including a short-wave range from 15 to 52 metres, are provided in the "Marquis" Model 502 and "Duchess" Model 504, the former at 12 gns. and the latter at 12½ gns. These sets are six-valve superheterodynes with a 5-watt output, and the "Marquis" model is available in a choice of coloured bakelite cabinets. The "Envoy" Model 604, like the "Duchess," is housed in a "horizontal" type walnut cabinet. It is designed for AC/DC operation, and costs 13 gns.

Finally, there is the "Ermine" Model 606 for AC/DC mains at 10 gns. It has a 6-valve superhet. circuit with a 15 to 52-metre short-wave range, and the output is 3 watts.

How the B.B.C. Puts the Clock Back

MOBILE RECORDING EQUIPMENT

THERE are many occasions when some happening provides first-class material for a running commentary, but often the event occurs at a time inconvenient for broadcasting. If a potential item of interest of this sort is not to be lost, the only thing to do is to record it so that it may be broadcast at a more convenient time. It is for this purpose that the B.B.C. engineering staff have recently designed and equipped two recording vans. These vans, the design of which is the result of eighteen months' experimental work, are mounted on 29.4/78 h.p. chassis and are divided into three compartments, namely, driver's cab, studio and apparatus room. The studio has a glass observation turret giving a view all round the van. The roof is specially

strengthened to carry several people, so that, if necessary, a running commentary can be given from it.

Power is obtained at 100 volts from a battery of accumulators of large capacity. This battery can be charged from a generator on the van or *via* a mercury-arc rectifier from ordinary AC mains. Each van has two entirely

The B.B.C. Mobile Recording Van is seen outside the Guildhall, while the mixer unit and microphones are shown being rigged up for use on another occasion. Below is a photograph of the recording turntables in a special compartment adjacent to the amplifier rack on the right.

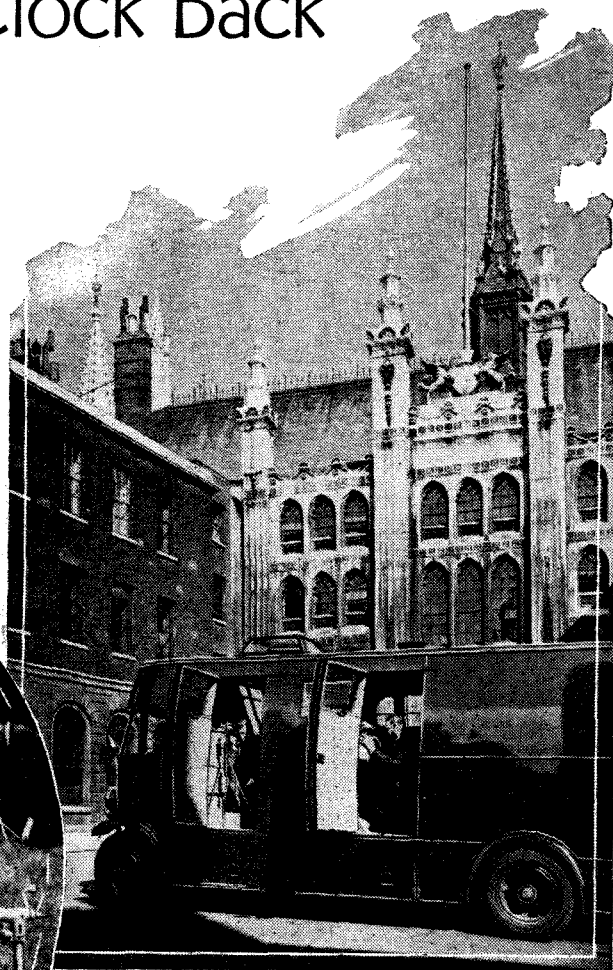

separate recording channels, each channel possessing a four-stage microphone amplifier and a push-pull output stage to drive the cutting-head. A separate battery-excited motor generator is used to supply power to each of these two channels.

The maximum gain of each channel is 120 db at 1,000 cycles per second, the average output at this frequency being 8 watts. A special input meter across the cutter terminals gives visual indication of the programme level being recorded, and the gain of the amplifier is adjusted accordingly by means of a potentiometer between the first and second stages of the amplifier. Aural checking of the programme is provided for by means of a loud speaker operating from a two-stage amplifier connected to the output of the microphone amplifier, it being possible also to use this loud-speaker equipment for play-back purposes. The turntables are driven by $\frac{1}{2}$ h.p. DC motors worked from the battery, and their speed is checked by a neon lamp stroboscope operated from a 50-cycle tuning fork.

The microphone equipment consists of a portable mixer capable of accommodating five microphones. This mixer is usually placed at some distance from the van, and the microphones can be taken as far as a quarter of a mile from it, the necessary cable being wound on special drums so constructed that it is not necessary to unwind them fully for use over distances less than the maximum. Communication is maintained between van, mixer and microphone by means of a "party line" telephone, a visual cue system being used when actually recording. In addition to this, the programme which is being recorded can be heard *via* headphones at the mixer and at all microphone points.

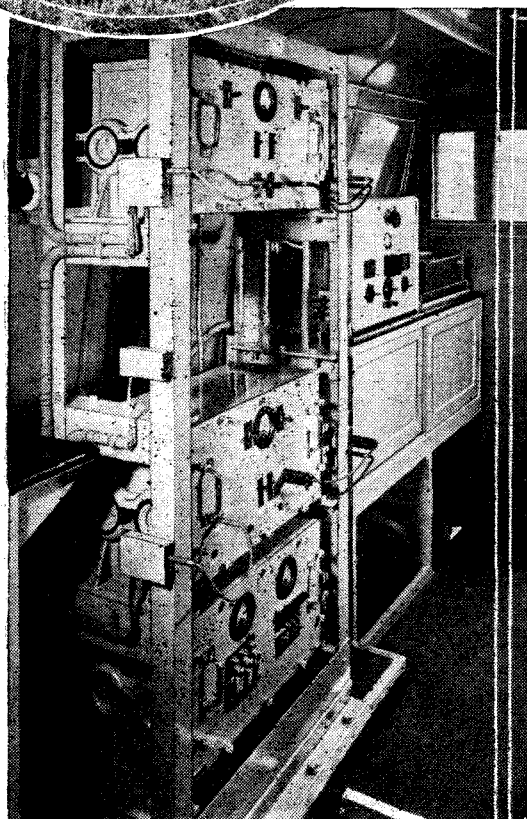
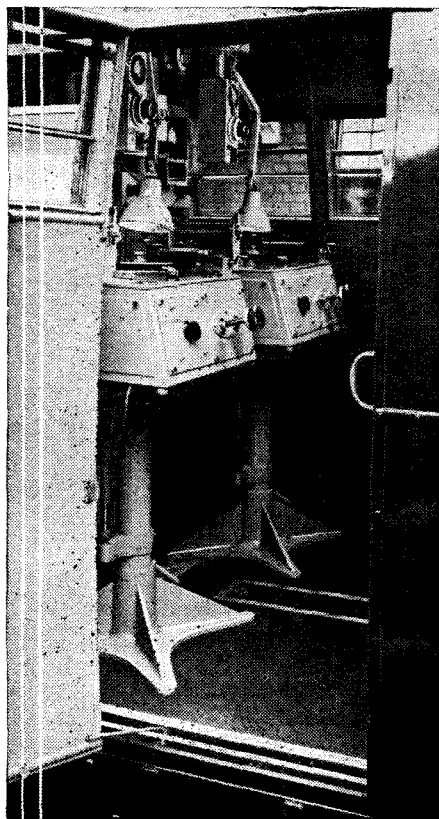

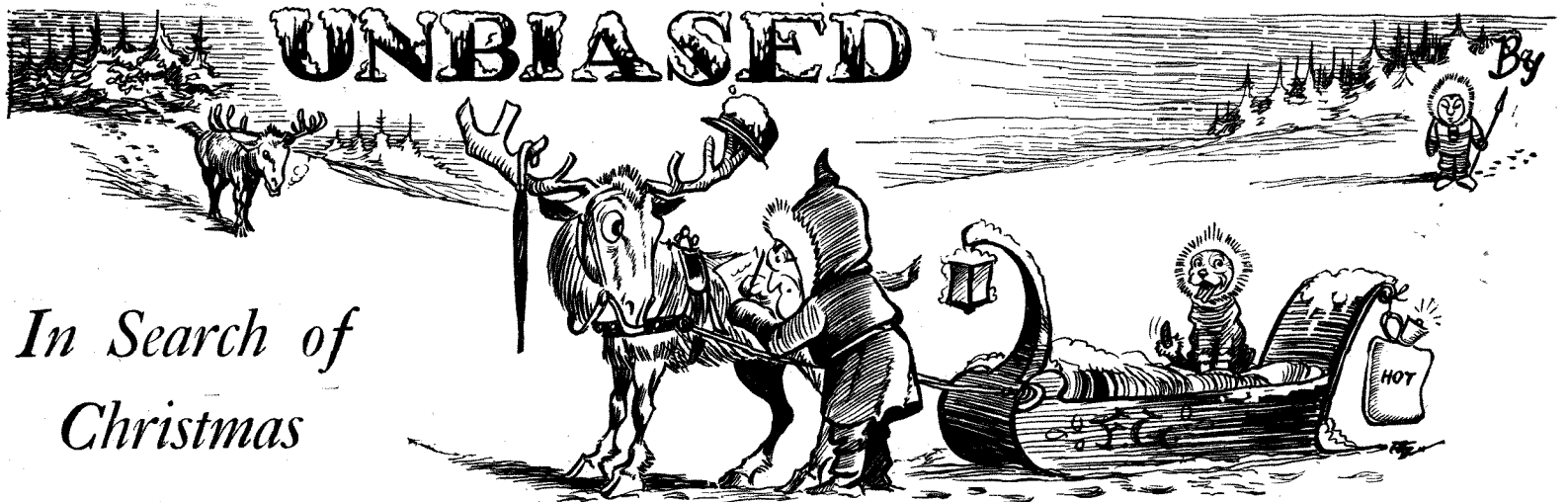

In Search of Christmas

I TRUST that you will forgive any slight symptoms of disjointedness and scrappiness in these notes this week in place of the smooth and flowing examples of Shakespearian prose which you are accustomed to expect of me, but I find it extremely difficult to keep up a fluid style of writing when even the very ink in my pen keeps on freezing, and I have constantly to get up and hold it in a candle flame before I can resume.

The truth is that I am writing these words in the frozen wastes of the Great White North—or, to be more precise, in Lapland—surrounded by reindeer and suchlike creatures, with the wind souging drearily through the pine trees, to say nothing of suspicious-looking Lapps who seem to take me for a new kind of tax collector who has descended upon them. Apart from the melancholy nature of my surroundings, I am suffering from chilblains, not only on my hands and feet, but also on my nose, and in addition I have a nasty cold and more than a touch of rheumatism.

The cause of all these evils of the flesh is, it need scarcely be said, the same as that which brought about all the troubles between Greece and Troy centuries ago, namely, women. You will remember that in that particular instance it was one woman who was at the bottom of all the trouble, namely, Helen of Troy, whose face was said by my fellow scribe, the ever-truthful Homer, to have launched a thousand ships. In my particular case the circumstances are rather different, and my present troubles are due not to one but to a number of women, and, while I would not be so ungallant as to suggest that their faces would launch a thousand ships, they would certainly stop a bus.

Many of you will probably recollect that I have invariably interested myself in the social activities of the village wherein

I live, more especially at Christmas time, when the vicar usually enlists my services in the interests of the village children at the great annual party which is held in the parish schoolroom. This year the usual women's committee which organises the wretched thing started their annual bickering and quarrelling over it early in October. After a large number of meetings, at which the customary pleasantries were exchanged about each other's personal appearance, it was proposed that wireless as usual should play a prominent part in the festivities.

On the Trail of the Lonesome Pine

There were unfortunately several dissentients to the proposal, in particular a cantankerous and formidable-looking specimen of the female species of *homo sapiens* who contended that wireless was far too modern to be associated with such an old-fashioned thing as Christmas, and, in any case, after the unfortunate contretemps of last Christmas, it ought not to be allowed. After a lot of sentimental slush had been talked about the good old

days when Christmas was Christmas, it was agreed by the committee that wireless should be permitted but that its modernistic effect should be offset by making all other aspects of the party of the real old-fashioned type. Since I was to be responsible for the wireless part of the entertainment it was decided that I was the proper person to be in charge of the old-fashioned off-setting stunt. The upshot of the matter was that I was despatched to Europe, to all the legendary haunts of Father Christmas, in order to study the local folk lore and to soak myself in the psychic atmosphere of this so-called festive season.

After wandering through the Black Forest and then crossing the frontier into

Bohemia and visiting the castle of Good King Wenceslas in the ancient city of Prague—where the local inhabitants regarded me as the emissary of an American film company looking for a setting for a Christmas feature film—I finally worked my way up north in my vain search for Santa Claus, and landed in Lithuania, where I picked up a hot scent, as every other person seemed to be named Claus, or something very like it. Unfortunately, my enquiries aroused the suspicions of the authorities and I was escorted from the



The village educational authority.

Christmassy city of Miklas across the romantic bosom of the River Schnitzki-Gomitcka and given a free pass to the Great White North. Needless to say, I lost no time in setting out for the land of reindeer and elk, where I am now.

Roboxmas

The real reason why the women's organising committee were so chary of letting wireless have its due share of the festivities was that they were afraid of a repetition of last year's unfortunate occurrence, and, after all, I suppose you can hardly blame them. At the party a year ago I attempted, rather unsuccessfully, I fear, to bring Father Christmas completely up to date by turning him into a radio robot. The technical part of the job bristled with difficulties, but such things are, after all, sent into this world for the express purpose of being overcome, and I flatter myself that the automatic Santa Claus which I eventually turned out was in a class by itself. The whole of the figure was driven by an intricate system of miniature electric motors, these being controlled by an ultra-short-wave receiver—



In the ancient City of Prague.

Free Grid

or rather a series of them—situated appropriately enough in the head of the figure. The robot was, of course, clothed in the conventional robes of the Yuletide saint, and was remotely controlled through a small portable transmitter, and, in the preliminary tests, behaved faultlessly.

There was only one snag, that being that there was no convenient place for me and the transmitter where I could see and not be seen, until eventually I thought of the chimney. After a great deal of argument I was able to persuade the village educational authorities, in whose headquarters the party was to be held, that the heating arrangements of their establishment needed to be completely modernised and the old-fashioned Yule log turned into an electric one. This having been done, it did not take me long to rig an eyrie for myself sufficiently far up the chimney to be beyond the radiations of the electric fire, and to arrange an inclined mirror in such a manner in the lower part of the chimney that I commanded a good view of the schoolroom. The fact that Father Christmas was to arrive by such a super-modern means as radio was advertised widely in the village, the only thing that was kept secret being the exact location of myself and the controlling transmitter.

The Mistletoe Bough

At the appointed hour everything seemed to go without a hitch, and my radio-controlled automaton made an impressive entry, and beyond treading rather heavily on the toes of the local schoolmistress there were no untoward incidents. The voice of Father Christmas was managed by means of a small loud speaker in the head, and owing to the distortion produced by the poor acoustic conditions in this confined space I had no difficulty in disguising my voice so that it fitted in well with the conventional figure of the saint. My radio robot under my skilful distant manipulation had distributed a large number of gifts from the capacious bag at its side, and, in the words of the Parish Magazine, a good time was being had by all when the first distant rumble of approaching trouble was heard. The regrettable part is that the whole affair would have gone off with flying colours had the distribution of gifts finished five minutes before it actually did.

I had unfortunately completely overlooked the fact that we were well within range of the experimental ultra-short-wave television transmitting station of one

of the two companies who are now doing their stuff at the Alexandra Palace. It was unfortunate that their transmitter should have been using kilowatts whereas mine was only employing milliwatts, but it was, of course, pure chance that the incoming modulation should have so acted on the controls of my robot that, instead of keeping its arms to the business in hand, it was led into certain unpardonable familiarities with the ladies present. My frantic efforts to regain control of it were completely unavailing, and breaking-point was reached when the automaton



Swept out of the room like a ship under full canvas.

approached the Squire's wife, a formidable female of uncertain years, and gave her a playful 'chuck' under one of her many chins.

The good lady at once rose in awful majesty and began to sweep out of the room like a ship under full canvas, and I realised at once that unless something drastic were done immediately there was a grave danger of all the other ladies following her lead, so causing a complete fiasco, to the great disappointment of the little ones for whose enjoyment the party had been organised. Accordingly I threw all caution to the winds and, reverting to my own natural voice, I at once began to explain, as best I could, the cause of the trouble.

Unfortunately, the technical education, to say nothing of the intelligence of the women and children of this country, as I have frequently complained, is at a deplorably low level, and the result was that not only was I disbelieved, but everybody came to the conclusion that I had been deceiving them throughout, and that the robot was no robot at all but consisted of myself in disguise, and, furthermore, that I was abusing my position in order to indulge in unseemly levity at the expense of the ladies present. The result was that the undercurrent of insubordination and

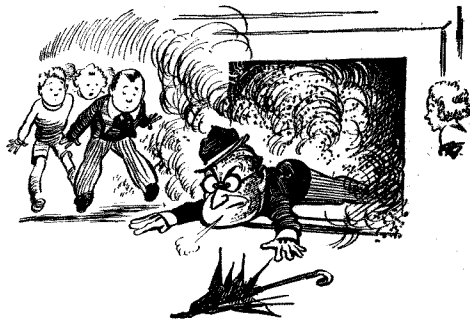

... my undignified position.

revolution which is for ever present in the breasts of the younger generation burst into the open and, with a reverberating crash, a volley of tangerines, nut-crackers and bananas smashed into the face of the robot, thus destroying hundreds of pounds' worth of delicate machinery at one fell swoop, the children thinking that I was inside the figure in person.

I can only suppose that in my surprise and anger at being the unwilling witness of this utterly wanton act of destruction I must have craned my neck a little too far and so upset the delicate balance of my little eyrie up aloft, as the next moment both I and my portable transmitter were precipitated violently down the chimney and arrived in the grate to the accompaniment of a confused medley of feminine shrieks together with tears and exclamations of fear on the part of the younger children who had imagined that Nemesis, in the form of Old Nick himself, with whom their nurses had so often threatened them, had at last materialised.

To make confusion worse confounded, in my efforts to extricate myself from my undignified position I unfortunately became entangled in the electric wiring of the lighting and heating installation and the fuses blew with a resounding report, the whole place being plunged into darkness. Needless to say, this did nothing to allay the fears of the children, and instantly Bedlam was let loose.

When candles were eventually brought and some semblance of order restored the sight that met my eyes was indeed a sorry one. Apart from the spectacle which I myself must have presented in the grate, the room was in wild confusion, the floor being a litter of trampled toys, oranges and other Christmas fare, mingled with the remains of my robot and about a hundred pounds' worth of auxiliary gear. Dotted here and there were groups of bawling children, while everywhere were beruffled-looking females frantically struggling into their outdoor clothes. To crown all, I found that I had fallen headlong through my viewing mirror, thus assuring myself of seven years' bad luck.

Greenland's Icy Mountains

However, the recital of all this does not help me much in my present uncomfortable situation. I have as yet to make my way to Iceland and Greenland. Judging by the unappetising names of some of the places around the inhospitable shores of the latter place, I entirely fail to appreciate what Hans Andersen and the brothers Grimm could see in it. I think I shall be content to pay a brief visit to Cape Desolation and to the Bay of Utter Despair. By that time I shall probably have gathered all the local colour I need and shall be able to bid a thankful farewell to the cape of that name. I had thought of going on to Labrador afterwards, but honestly I don't think my constitution would stand it.

In the meantime, I wonder if any of you would, out of the kindness of your hearts, do something for me pending my arrival back in the old country for Christmas, and that is to send me along, care of the Editor, any old-fashioned recipes or prescriptions you may know of for the alleviation of colds and rheumatism. I have always been a believer in these old-world homely remedies and I cannot help thinking that they are just what I want to ensure a really peaceful Christmas.

Broadcast Brevities

NEWS FROM PORTLAND PLACE

Maida Vale's New Organ

NO flourish of trumpets or widespread publicity greeted the advent on the air of the third of the B.B.C. organs; but on two or three occasions, unknown to listeners, it has been included in orchestral programmes from Maida Vale, and has already proved its worth as a welcome change from the Concert Hall organ and the instrument over which Reginald Foort presides in St. George's Hall.

Three-manual

The Maida Vale organ has been designed primarily for use with choral and orchestral work, and its purposes as a solo instrument have been of secondary consideration. It is a three-manual, and is enclosed in two expression chambers. It is constructed throughout on the extension principle, and is thus more resourceful for the comparatively small space which it occupies on the platform at the end of No. 1 studio.

For Accompaniments and Solos

The Great organ of fifteen stops has a very rich diapason chorus and the ensemble is dignified and powerful. The Swell organ of twelve stops, besides providing a "full swell" of the most brilliant and traditional kind, has a wealth of soft stops which can be used either for accompaniment or solo purposes.

Full Organ Effects

On the Choir organ of twenty-three stops are available some very delightful smaller ensembles of the diapason, string and flute tones. In addition, a bombarde is playable on this manual, giving the effect of solo tubas and a variety of reed choruses. There is also a separate six-rank mixture on this section, so that a Full organ contrasting with that of the Full Great can be obtained.

Luminous Stops

The Pedal organ of thirteen stops has a thirty-two foot register of actual pitch, besides a composite thirty-two foot which gives the effect of a reed bass. In addition, there are two sixteen-foot reeds and three five-foot stops of sixteen-foot pitch. This department provides a suitable bass for any combination in the organ. The control of the organ is by luminous stops, similar to the instrument in the Concert Hall, Broadcasting House. This control, besides being extremely simple to operate, allows the organist to see immediately which stops he has drawn.

All the thumb pistons are instantly adjustable to the console, so that a visiting organist can set his controls according to his requirements. The console is detached and movable on rubber-tyred wheels.

Television Greets a New Year

IT has been suggested that a special midnight show from Alexandra Palace on December 31st would be an excellent way of heralding the New Year which will mean so much to television.

Unfortunately, the scheme is not in the realm of practical politics. Already the Productions staff at "A.P." is taxed to the uttermost to provide 120 minutes of pictorial entertainment a day, and to add even

"kept alive" for two hours in one day.

A stage play is in preparation for at least three weeks, and the run may be expected to be not less than three months. In television there are new shows each afternoon and evening, with a run of one day.

So there will be no midnight television on New Year's Eve. There will, however, be a special "Hogmanay" feature towards the end of the normal evening programme, with the Television Orchestra in a very important rôle.

Breastplate Microphone

WITH a microphone as a sort of breastplate, John Watt will again this year visit



THE THIRD B.B.C. ORGAN. The console of the new Maida Vale organ photographed at the John Compton organ works during its construction. Although smaller, it is similar in many respects to that in the Concert Hall, Broadcasting House.

one extra hour to the programme output for 1936 might break the camel's back.

No Parallel on Earth

It is probably not generally realised that the handful of producers and stage managers at the Television station are actually performing tasks which have no parallel on earth. An army of staff in the average film studio has done a good day's work if it turns out three or four minutes of screen entertainment in one day. At "Ally Pally" the screen must be

the Chelsea Arts Ball and mix among the revellers in order to broadcast descriptions of the hilarious scene. It is an event of considerable anxiety to this well-known B.B.C. producer; for the microphone is connected to some sixty feet of flex, and as Mr. Watt moves about the crowded dance floor there is imminent danger of someone tripping over the wire. One of the B.B.C. engineers will do his best to prevent such a catastrophe and the consequent ruin of the broadcast by guiding the flex clear of the dancers'

feet during Mr. Watt's progress. Although this method has been used during Floor Shows, the size of the audience has not made it such a complicated matter as it will be at the Chelsea Arts Ball.

New Empire Wavelengths

THE use of an additional wavelength is being considered for Empire transmissions, due to the recent increase in Empire Service activity. As an experiment, it is proposed to go down to as low as 11.49 metres (26.1 Mc/s). The minimum wavelength at present in use is 13.93 metres (21.53 Mc/s). The new wavelength will be known as GFK and will come into operation very shortly, being used for transmission to Africa.

The Next "Scrapbook"

LESLIE BAILY and Charles Brewer are now collecting material for their next "Scrapbook," which will deal with the year 1919, when the world was staggering to its feet after the Great War. "Scrapbook for 1919" will be broadcast towards the end of January.

Airship and 'Planes in Record "O.B."

THE B.B.C. may glean some valuable hints for outside broadcasting by studying the lavish plans of America's National Broadcasting Company in connection with the forthcoming inaugural ceremonies of President Roosevelt and Vice-President Garner on January 20th next.

At least one airship and a number of 'planes are being chartered for a squad of flying commentators; in addition, there will be "ace" announcers stationed on top of the Washington Monument, in the dome of the Capitol, along Constitution Avenue, in the grounds of the White House and at the Presidential Reviewing Stand.

Graham McNamee or another veteran commentator will occupy the post of honour on the steps of the Capitol.

Relay by B.B.C. ?

Nor is this all. Microphones will also be in action on two mobile broadcasting units, at several micro-wave transmitters and also on an observation balloon which is to pick up the great waves of applause.

It is expected that the B.B.C. will relay part of the ceremony at about 2 p.m. (G.M.T.). It is not yet decided, however, whether the transmission will be picked up by Tatsfield from 2XAF (Schenectady), or by Transatlantic beam.

Christmas Wireless Fare

HOLIDAY PROGRAMME PLANS



THERE is little doubt that at no other time of the year are wireless receivers put to such continuous use as during the Christmas holidays. For whether it be at the family party or in the quiet of one's own room, listeners expect something seasonable in the way of entertainment. In fact, it would now be difficult even to imagine what Christmas would be like without wireless.

What, then, will be the fare for listeners during the festive season? From the programme details which are available at present, it is clear that the Director of Programme Planning, Mr. Charles A. Siepmann, and his satellites have again tried to suit the tastes of all classes of listeners.

Christmas Day

The day starts with a service from St. George's Chapel, Windsor, which will be transmitted by the National and Regional stations, and in the early evening another service will also be broadcast, this time from the Concert Hall, Broadcasting House, radiated Nationally.

From 9.20 to 11 p.m. comes "Henry Hall's Christmas Tree," which will be decorated with such well-tried favourites as Turner Layton, Haver and Lee, Oliver Wakefield, who will infuse a Yuletide flavour into his witty running commentar-

be having a hectic time during the holidays and the preceding days. They appear in the programmes on December 22nd and 23rd, twice on the 25th and twice again on the 26th, and so many engagements obviously necessitate intensive rehearsals.

Charles Brewer has for the last three years been responsible for the Christmas Radio Party. Its intimacy is surely the keynote of its success, although the apparent spontaneity of the remarks, etc., is actually due to very careful rehearsals. But for all that, it still comes over as a jolly party of friends. It is hoped that "the old Christmas gang" will again be present, including Tommy Handley, Clapham and Dwyer, and the Two Leslies. Besides these artistes, the majority of the Light Entertainment Department's producing staff and any stray B.B.C. official who may be on duty at Broadcasting House at

ENJOYING the joke put over by the Western Brothers during a Christmas party broadcast. Among those grouped around the piano are Stanelli, Henry Hall and Bryan Michie and on the right (side face) is Eric Maschwitz. Below Henry Hall is conducting his Music Makers with the Three Sisters, Molly, Marie and Mary and Dan Donovan standing before the microphone.



ies on dance tunes, and, of course, Henry's own "family," Molly, Marie and Mary, Dan Donovan, George Elrick and the Music-Makers, not forgetting the full orchestra. The B.B.C. Dance Orchestra will

the time will also be present at St. George's Hall. This annual broadcast brings the largest mail of appreciation of any programme of the year, possibly because listeners realise that these popular artistes

are giving their Christmas holiday for the public weal.

The Children's Hour will, no doubt, be enjoyed by many "older children," for it consists of Charles Dickens' "A Christmas Carol," adapted as a radio play by Philip Wade.

Boxing Day

This offers little more than any of the other fifty-one Saturdays of the year. It is, of course, the opening day of the pantomime season, and for those who are unable to go to a theatre there will be in the Regional programme during the afternoon "Sinbad the Sailor," or "A Life on the Ether Wave." There will also be a running commentary from Twickenham by Captain Wakelam on the annual rugby

match between the Harlequins and Richmond.

Throughout both days a considerable part of the programmes is occupied by light orchestral and dance music. Among the well-known combinations which will be heard are the Coventry Hippodrome Orchestra, Hastings Municipal Orchestra, Eugene Pini and his Tango Orchestra and the London Symphony Orchestra.

Many of us are apt to forget those who man the broadcasting ship throughout the Yuletide holidays and give us a consistent service to meet our requirements for the festive season. So, perhaps, during this season of good cheer we can spare a kindly and appreciative thought for them.

The times of the individual programmes will be given in the Listener's Guide pages in the issue of December 25th, which will be on sale on the previous day.

AN institution which is of great service to those who occupy their business in great waters and yet is little heard of by the man-in-the-street comes into the programmes this week. It is Trinity House, the institution watching over navigation around our coasts. Listeners will learn of the workings of this Corporation when H. L. Morrow presents a programme featuring it on Wednesday at 10.35 (Nat.) and



PILOTAGE will be dealt with in the Trinity House feature programme on Wednesday. These two "stills" from the film "Pilots of the Port of London" produced by Visual Education show (left) a pilot cutter coming alongside a vessel and (above) a pilot boarding a liner to take her up the river.

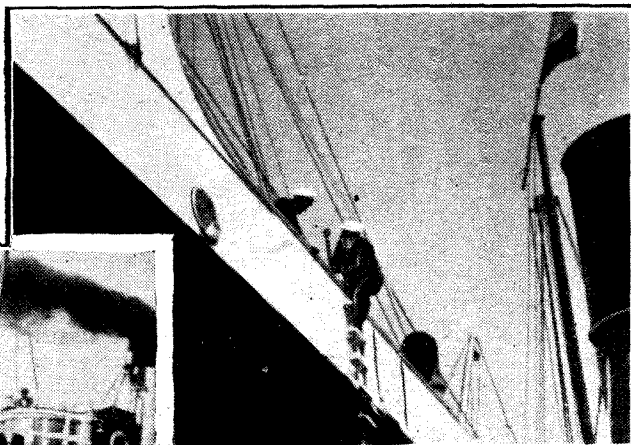

again Regionally on Friday next.

The early history of Trinity House, which is responsible for maintaining lighthouses, lightships and pilot services, is lost in the obscurity of the late Middle Ages. Originally a charitable institution, it has grown into the most important maritime organisation of the British Isles. Lighthouse-keepers, officers and crews of several East Coast Lightships and pilots of the Ports of London and Southampton will be introduced. At both of these ports the microphone will be taken on board an incoming ship, and listeners will be able to hear what actually happens on the bridge of a great liner as the Trinity House pilot takes over.

CARNIVAL

COMPTON MACKENZIE'S moving play, "Carnival," will be revived in the Regional programme on Monday at 8. It was first produced in 1929, and was again heard in 1923. Peter Cresswell will again be the producer. At the first broadcast in January, 1929, every studio at Savoy Hill was pressed into service, and arti-

ficial echo was used for the first time.

Harmon Grisewood, the original Maurice Avery, is now an announcer; he was first discovered by Peter Cresswell for this part, and thus began his long and successful association with broadcasting. Noel Dryden will play the leading rôle in the new production. Listeners will again hear Hermione Gingold as Maudie Chapman, Billie Sinclair as Irene Dale, and Marjorie Gabain as the spiteful Madge Wilson.

THE WEEK'S MUSIC

THE blind English composer, Herbert Ferrers, author of the operas, "Penelope" and "The Piper," will to-night at 8.15 (Reg.) conduct the first studio performance of his "Songs of a Roman Legion," with poems by Rudyard Kipling, which will be sung by the B.B.C. Men's Chorus accompanied by Section E of the B.B.C. Orchestra. Choral works by another English composer, Leslie Woodgate, will also be broadcast in this concert.

Yet another new work by an English composer will be given its first performance when May Harrison plays Gordon Jacob's "Fiddle Concerto" during the programme by the B.B.C. Orchestra (Section B) on Wednesday at 7.45

Details of the week's Television programmes will be found on p. 631.

Listeners' Guide for

LABOUR

DISCUSSIONS invariably make good broadcasts, and especially so when the subject is one of general interest. Such will be the case when "Non-union Labour" is discussed at the third meeting of "Midland Parliament" on Saturday at 8.15 (Reg.). Sir Charles Mander, Mayor of Wolverhampton, will be in the chair. W. M. W. Thomas and Austin Hopkinson, M.P., will speak as employers, and the Trade Union side will be represented by George Jones, of the Midland Miners' Federation, and Arthur Henderson, M.P.

REUNION OF WIRELESS LISTENERS

(Nat.). Gordon Jacob is Doctor of Music at London University and Professor at the Royal Academy of Music.

The special recital series for this week is headed "The Violin in Italy," and includes works by Pergolesi, Corelli, and Veracini. The first recital is of sonatas played by Eda Kersey on Sunday at 4 (Reg.). Instrumental music played by the Boyd Neel String Orchestra will form the second at 6 (Reg.) on Monday. The third, on Tuesday at 9.40 (Nat.), and the fifth, on Friday next (Nat.), consist of violin sonatas played by Jean Pougnet with Betty Humby at the piano. The fourth comes on Thursday in the National programme at 8, when works for two violins will be executed by Jelly d'Aranyi and Adila Pachiri, who, by the way, are sisters.

CINE-VARIETY

ERIC MASCHWITZ, the Variety Director, is experimenting with the possibilities of increasing co-operation between his department and the variety side of cinema entertainment. His first experiment is to be staged at the Regal Cinema, Kingston, on Tuesday at 9 (Reg.) when listeners will hear Florence Desmond, Clapham and Dwyer, Norman Long, and Gipsy Nina, with Harold Ramsay at the organ playing a selection of listeners' most frequent requests.

THE REV. W. H. ELLIOTT, who is so well known for his mid-week services from St. Michael's, Chester Square, has arranged a reunion of listeners at the Albert Hall on Thursday to mark the completion of five years of this popular broadcast. Within a few days of launching the idea he had received more than 11,000 applications, whereas the seating capacity of the Albert Hall is something like 7,500.

The evening will include community singing led by a choir, the music being provided by the Band of the Royal Air Force, and will conclude with a simple service typical of those heard from St. Michael's; this is the only part being broadcast and it will be heard Nationally at 10.



FRANCA SOMIGLI, who takes the part of Elsa in the opera "Lohengrin" which Milan is relaying on Saturday.

the Week

Outstanding Broadcasts at Home and Abroad

SWEDISH MUSIC

AN interesting programme of representative Swedish orchestral music will be heard from the Swedish stations on Tuesday at 9, played by the Radiotjänst Wireless Orchestra, conducted by the leader of the Royal Swedish Opera, Nils Grevillius.

OLYMPIC MEMORIES

A SYMPOSIUM of recordings of musical and sporting events from the eleventh Olympic Games will be broadcast from 6-9 on three evenings this week. It will include the more important items broadcast during the time of the Games. This programme will

be heard from Deutschlandsender, Breslau and Konigsberg on Monday, from Berlin, Leipzig, Munich and Hamburg on Tuesday, and Frankfurt and Stuttgart on Thursday.

OPERA

OPERA from the Continent is scarce again this week. Tonight (Friday) at 7.10 Prague and the other Czech stations give a representative concert of Czech opera music. It consists of excerpts from Smetana's "Two Widows," Dvorak's "Jacobin," Blodek's "In the Well," and a less familiar work, "The Dog-Heads" (Psohlavci), by Karel Kovarovic.

Saturday brings a part-relay by Beromunster from 8.45-10 of Mussorgsky's opera, "Boris Godunov," from the Municipal Theatre, Basle. Apparently it is the original version, not Rimsky-Korsakov's orchestration. The same evening (8-11) brings a full-dress performance of "Lohengrin" from the Royal Opera, Rome, broadcast, however, not by the Rome station, but

ST. MARTIN-IN-THE-FIELDS, seen from Trafalgar Square. The Rev. Pat McCormick will, as usual, give the address during the broadcast service on Sunday at 7.55 which will be relayed by both the National and Regional stations. He will afterwards make his annual appeal on behalf of St. Martin's Christmas Fund.

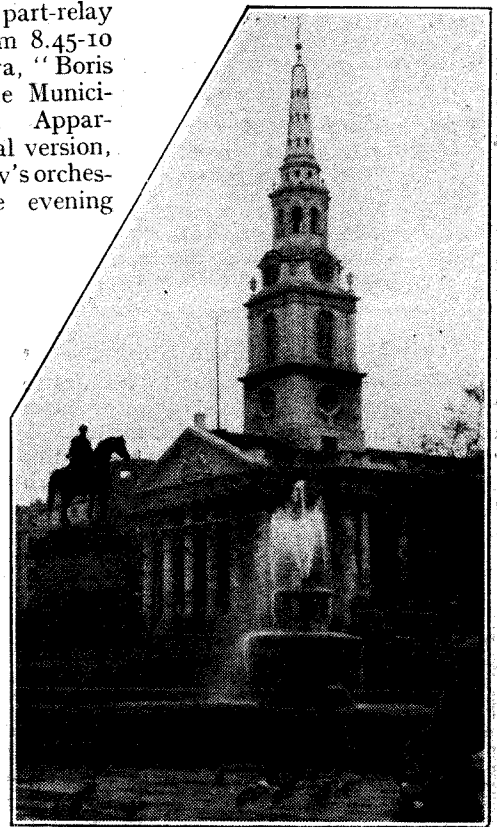

HIGHLIGHTS OF THE WEEK

FRIDAY, DECEMBER 11th.

Nat., 5.15, Yascha Krein and his Gypsy Orchestra. 8, Sandy Powell's Album. 9.20, Talk: "The Flotsam of War"—Philip Noel Baker. 9.40, Comic Opera programme.

Reg., 6, Peggy Cochrane—"A Tune a Minute." 7.30, B.B.C. Dance Orchestra. 8.15, B.B.C. Orchestra (E) and Men's Chorus.

Abroad.

Vienna, 6.35, Ravag Music Society's Subscription Concert—Vienna Symphony Orchestra and Adolf Busch.

SATURDAY, DECEMBER 12th.

Nat., 5.15, B.B.C. Dance Orchestra. 7.30, "In Town To-night." 9.20, Music Hall (including the Two Leslies and Alexander and Mose).

Reg., 3.30, "Madam Butterfly"—Act II from Sadler's Wells. 6.30, Cheerful Songs by the B.B.C. Men's Chorus. 9, Concert from The Colston Hall, Bristol.

Abroad.

Strasbourg, 8.30, Concert by the Vienna Boys' Choir.

SUNDAY, DECEMBER 13th.

Nat., 4, Advent Oratorio Programme. 5.40, "King Lear." ¶Leslie Jefferies and the Grand Hotel, Eastbourne, Orchestra.

Reg., 5, Orchestre Raymonde and Billy Mayerl. 6, Victorian Melodies—X. 9.5, Ninth Sunday Orchestral Concert

Abroad.

Paris PTT, 8.30, "La vie parisienne"—Offenbach.

MONDAY, DECEMBER 14th.

Nat., 7.20, Sixth "Entertainment Parade." ¶B.B.C. Orchestra (E) and Sadler's Wells Ballet. 9.35, Reginald Foort at the Theatre Organ.

Monday, December 14th, (cont.)

Reg., 6, The Birmingham Theatre Royal Orchestra. 8, Compton Mackenzie's "Carnival."

Abroad.

Leipzig, 8, Concert of Tyrolese Composers' Works.

TUESDAY, DECEMBER 15th.

Nat., 6.25, Pianoforte Recital—Stefan Askenase. 7, "Christmas in the Rockies"—The Rocky Mountaineers. 8, Harry Hopeful's Party. ¶The B.B.C. Orchestra (C) and Frank Lafitte (piano).

Reg., 6, The B.B.C. Military Band and Robert Easton. 9, Variety from the Regal Cinema, Kingdon.

Abroad.

Deutschlandsender, 8.40, "Richard Strauss and his Symphonic Works"—"Macbeth."

WEDNESDAY, DECEMBER 16th.

Nat., 7.15, Van Phillips and his Two Orchestras. ¶"Old Words to New Music." 10.35, "Trinity House."

Reg., 7.30, Songs from "The Princess"—B.B.C. Singers (A). ¶At the Red Sarafan. 8.45, Leslie Bridgewater Quintet.

Abroad.

Kalundborg, 7.45, Works of the Strauss family.

THURSDAY, DECEMBER 17th.

Nat., 6.20, "This Way Out"—John Hilton. 7.45, Introductory Talk to Contemporary Music Concert.

Reg., 6, Music of Montague Phillips—B.B.C. Orchestra (C) and Clara Butterworth. ¶"Old Words to New Music." 9.15, G. Thalben Ball at the Concert Hall Organ.

Abroad.

Hamburg, 7.10, "All Dance!"—Station Dance Band.

by the North Italian group, from Milan. Verdi's "Falstaff" comes from Rome at 8 on Sunday.

On Monday at 7.10 Hamburg gives a Heinrich Marschner evening from the Hanover studio. Heinrich Marschner was a fine old composer of the last century. He wrote some dozen operas in the dramatic tradition of the romantic school.

Milan and the North Italian group at 8 on Tuesday take Mascagni's opera, "Nerone," from the Royal Opera, Rome. The veteran composer himself conducts. Italian broadcasting has reason to be grateful to Mascagni. He actually allowed the premiere of this, his most recent opera, to be broadcast, and has persistently helped and encouraged broadcasting. Wednesday brings "Lohengrin," relayed by Rome from the Theatre Royal at 7.45.

DANCE MUSIC

ACCORDING to a German listeners' voting competition last year the most popular dance band leader is Barnabas von Geczy. This Hungarian band leader and violinist makes a reappearance in the Deutschlandsender programme at 9.30 on Sunday, when listeners can be sure of hearing dance tunes played in an individual style.

ITALO-GERMAN

FROM 8 to 9 on Wednesday a number of German stations,

including Deutschlandsender, Stuttgart, Munich, Leipzig and Berlin, will be relaying a public concert from Rome. This Italo-German charity concert has been arranged on behalf of the Italian Winter Help Fund and in aid of the necessitous members of the German Colony in Rome. The Auguteum Orchestra will be conducted by Molinari, and the vocalists will be Erna Berger (German) and Giuseppe de Luca (Italian).

FIRST PERFORMANCE

A MODERN Swedish mass, the Missa Solemnis for mixed choir, full orchestra and organ by Josef Jonsson, will be performed for the first time on Wednesday during a concert which is being broadcast at 7.45 from the Stockholms Konserthörsförening and radiated over all Swedish stations.

EDUCATIONAL MUSIC

A NEW line in education by wireless will be launched by the Danish broadcasting authorities on Sunday at 11 a.m., when a special orchestral concert will be relayed from the concert hall studio of the Copenhagen broadcasting house. The hall will be filled with an audience of Copenhagen school-children who are invited to listen to some popular classical works and have their significance and composition explained by an expert lecturer.

THE AUDITOR.

READERS'

PROBLEMS

Where Filters Fail

A CORRESPONDENT who lives in a semi-detached house is somewhat disappointed at the result of fitting a condenser suppressor at the point of entry of the mains.

Reduction of background noise is much less than had been anticipated, and we are asked to say whether it is likely that interference is being re-radiated from

the wiring of the adjoining house.

This is more than likely, and it is quite possible that our querist's aerial might be even more affected by radiation from his neighbour's wiring than from his own.

It would be an interesting experiment to try the effect of fitting a condenser suppressor to the neighbour's mains as well; indeed, this is the only course we can suggest, short of advising the erection of a screened aerial.

Low-Gain AF Stage

A QUERIST who proposes to add an intermediate audio-frequency stage to his receiver realises that quite a small amount of extra amplification will be required and also that it is undesirable to provide more gain than is necessary. He therefore proposes to use a coupling resistance of abnormally low value.

This does not seem to be the best way to go about it, as amplitude distortion will be increased by excessive reduction of the anode

THESE columns are reserved for the publication of matter of general interest arising out of problems submitted by our readers. Readers requiring an individual reply to their technical questions by post are referred to "The Wireless World" Information Bureau, of which brief particulars, with the fee charged, are to be found at the foot of this page.

AC and DC Interference Suppressors

SOME confusion still seems to exist as to the appropriate connections for plain condenser filters for AC and DC mains. A querist who writes for information on this subject should be guided by Fig. 1, in which diagram (a) represents the correct connections for DC supplies. Although this arrange-

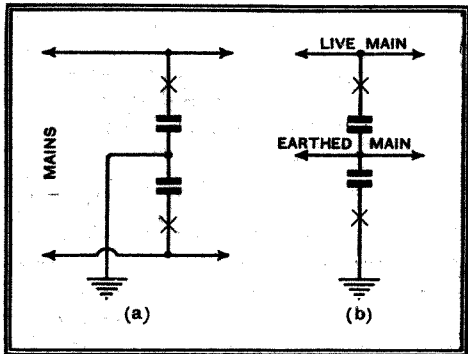

Fig. 1.—Basic anti-interference filter circuits, applicable either at the source or at the receiving end. Method (a) is for DC; method (b), which prevents the earth leakage that would otherwise take place through high-capacity condensers, is for AC supplies.

ment will also function on AC systems, it has the disadvantage of introducing appreciable leakage, and so the circuit of diagram (b) is to be preferred, as it almost entirely overcomes this trouble.

It should be observed that these circuits apply to all types of filters, whether connected as suppressors to interfering electrical appliances, as mains input filters, or as receiver-lead filters.

In the diagrams, the positions of fuses as commonly fitted are indicated by the letter X. It will also be noted that a ready-made filter unit comprising condensers and fuses may be correctly wired to either AC or DC supplies without internal alterations.

The QA Super

A CONSTRUCTOR of the QA Super notices that what he describes as a "bubbling" sound is produced when the receiver is tuned to a signal.

In our experience the effect described is invariably caused by a poor earth connection. If our querist finds it impossible to install a reasonably good "earth," a satisfactory alternative is afforded in most cases by connecting the chassis to one side of the mains through a condenser of between 0.01 and 0.1 mfd. As to which side of the mains gives the best results is a matter for experiment. The condenser used must, of course, be rated for working at the full mains voltage.

Another query on the QA Super relates to the provision of extra AF amplification, which may be necessary when the set is used with a rather insensitive pick-up.

This can be obtained by fitting a single-

pole change-over switch, wired so that, for gramophone reproduction, the lower end of R25 and one pick-up terminal are joined to the junction of R23 and R24 instead of to the junction of R20 and R21. The status quo must, of course, be restored for radio reception.

Through the HF Circuits

WHERE drastic tone correction is embodied in the LF circuits of a receiver as compensation for high-note attenuation in the RF or IF circuits, gramophone reproduction carried out by ordinary methods is bound to be more or less unsatisfactory.

A way out of the difficulty—and one which has distinct attractions for those using high-quality sets of certain designs—is, so to speak, to "play the records through the high-frequency circuits." This can be done by using the pick-up to modulate an oscillator valve placed in close proximity to the receiver.

To a correspondent who asks us to recommend a suitable modulation circuit we cannot do better than to refer him to an article on this subject that appeared in our issue of March 13th, 1936. The circuit re-

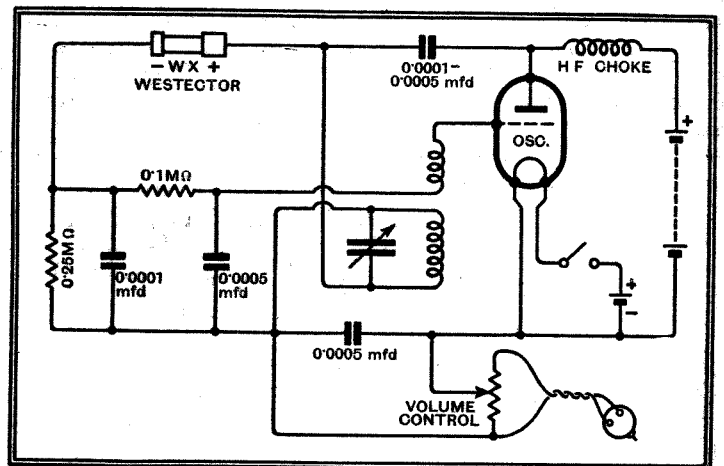

Fig. 2.—Using the pick-up as a modulator; a method of reproducing records when the receiver is unsuitable for the conventional system.

commended is reproduced in Fig. 2; although simpler arrangements could be devised, they are unlikely to prove so generally satisfactory.

The Wireless World INFORMATION BUREAU

THE service is intended primarily for readers meeting with difficulties in connection with receivers described in *The Wireless World*, or those of commercial designs which from time to time are reviewed in the pages of *The Wireless World*. Every endeavour will be made to deal with queries on all wireless matters, provided that they are of such a nature that they can be dealt with satisfactorily in a letter.

Communications should be by letter to *The Wireless World* Information Bureau, Dorset House, Stamford Street, London, S.E.1, and must be accompanied by a remittance of 5s. to cover the cost of the service.

Personal interviews are not given by the technical staff, nor can technical enquiries be dealt with by telephone.

load of the added valve. It would be better to use a normal value of coupling resistance and to insert an additional resistance between the anode of the valve and the coupling condenser, in such a way that this resistance, together with the following grid leak, acts as a potentiometer.

Is the Oscillator Oscillating?

IT is perhaps worth while to offer a reminder that the oscillator of a signal generator, or of any similar piece of apparatus, may be tested by the classical method applicable to the corresponding valve of a superheterodyne. A reader who is having trouble with a home-made testing oscillator seems to have overlooked this fact.

As to whether any valve is in an oscillating condition or not can readily be determined with the help of a milliammeter inserted in the "dead" end of the anode circuit. If a change of current is produced by short-circuiting the grid coil, all is well—or, at least, oscillation is taking place.

Ready for the Holidays?

TROUBLE-FREE
RECEPTION OVER
THE FESTIVE
SEASON

BROADCASTING comes into its own at Christmas time, and even if the programmes planned for the occasion hardly offer the interest of those of the past few years, they promise to be good enough at least to form an attractive background for the great family reunion. All the more reason why no hitch should occur in their reception, and it is the purpose of this article to suggest a way of carrying out a cursory overhaul that should reduce the risk of any serious breakdown.

So far as battery-driven sets are concerned it is hardly necessary to remind readers of *The Wireless World* to make sure that their LT and HT supplies are up to standard, and are likely to remain so over the holidays. But it is permissible—though rather unfashionable—to point out that no receiver can go on giving of its best indefinitely unless attention is given to the various contacts—switches, terminals, plugs and sockets, etc.—that are subject to corrosion. In those days when our receivers depended entirely on energy fed to them from the aerial this was a matter of vital importance; so much so that clean contacts sometimes made all the difference between good signals and no signals at all. Thanks to the vast reserve of amplification in modern sets that seldom happens nowadays, but the losses due to dirty contacts are there all the same, and manifest themselves by reduced sensitivity and selectivity, noisy background, and a general falling-off in performance.

Ensuring Low-resistance Contacts

Plugs and terminals are easily cleaned by a light rub with fine emery or sandpaper, followed by a wipe with a clean rag. Sockets are treated in a similar way, except that the abrasive paper should be twisted into the form of a spill and the cleaning cloth inserted with the help of a matchstick or something similar. Valve pins are dealt with in the same way as plugs, and if they are of the split "banana" type it is as well at the same time to open out the slots so as to ensure a close fit in the sockets.

Wave-change switches, even though they may give no indication of being out of order, are the better for periodical cleaning and adjustment, but the tyro should be very sure of his abilities before tackling this somewhat delicate operation. A method of cleaning, suggested in these pages by a service man of long experience, is to pass a strip of fine sandpaper, moistened with petrol, between the contacts with a to-and-fro movement; a pair of long-nosed pliers is generally required for carrying out the operation.

The question of replacing any valves that have declined in emission should next be considered. The enthusiast will already have a milliammeter, and will be *au fait* with the correct procedure for "breaking in" at a suitable point in each anode circuit; valves of which the current has fallen by 25 per cent. or more should be considered as due for replacement, at any rate so far as the output stage is concerned. Those who are not so well equipped, and are less familiar with their sets, may prefer to take the valves to a dealer for testing; the better sort of wireless shop, of the kind worth while encouraging and supporting, is now generally equipped with proper testing gear with which the operation can be carried out in the presence of the customer in a few moments.

Aids to Better Reception

On the question of replacements, it must be remembered that stocks of obsolete valves are not usually carried, and time may not allow a specimen of the original type to be obtained from the makers. But, except for valves that should really be museum pieces, a current type with characteristics sufficiently close to those of the original can generally be found. In such cases a certain amount of contriving may be necessary; a new type of valve holder may, for instance, be necessary, but the fitting and wiring of it will seldom present much difficulty; *The Wireless World* Diary gives the connections of all modern bases. Again, there is the possibility that the use of a "hotter" RF or IF valve than the original will produce instability, but as a rule this can be easily checked by reducing screen voltage by fitting a higher value of resistance in the feed circuit.

There is always a chance that the fitting of a new RF, IF or detector valve will impair the alignment of the tuned circuits. Now a complete "re-trim" of a superheterodyne is not a task to be undertaken lightly and without proper equipment, but there is not much to be afraid of in tack-

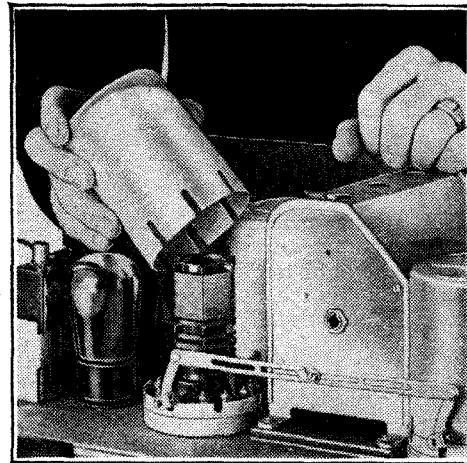

ling merely the two circuits that are affected by the replacement of a single RF or IF valve; a detector only affects one circuit, but a frequency-changer is rather more difficult.

Loud speakers are often adversely affected by the collection of dust and metal particles—it is a mystery where they come from—in the gap. Distortion produced by this cause is rather difficult to detect, but it is a fact that no speaker can work at its best in this condition; the trouble is that the deterioration is gradual, and so the ear becomes accustomed to the falling-off in performance. The presence of "foreign bodies" in the gap is generally shown by the presence of "brushing" noises. Ordinary dust may be blown out; not so iron particles. To get at these, the cone must be taken off, and the classical method of removing them is to use a strip of cotton wool saturated with vaseline, which is wiped round the inside of the gap by means of a strip of stiff card. Surplus vaseline should then be wiped off.

Re-centring of the diaphragm can be done with the help of a few packing strips of card of suitable thickness, spaced equally round the gap. Others prefer to carry out the operation by eye, patience, and trial and error.

Echoes and Television

"CATHODE RAY" had something to say recently about the "tunnel effect" on the 13-metre band, by which the echoes are produced by signals that have travelled once (or more than once) round the world. Most short-wave enthusiasts have probably heard this queer effect, and many will be able to bear out, from personal experience, his statement that the echo may follow the original signal after an interval of several seconds. These echoes proved a formidable obstacle to long-distance television when experiments with low-definition systems were made some time ago on the short waves. The primary image was often found to be accompanied by "ghosts," due to the tardy arrival of round-the-world impulses. When more work has been done on the long-distance reception of ultra-short waves, shall we find the same kind of thing occurring? If so, DX television by present methods may have to remain an unattainable ideal unless and until some way of laying the ghosts can be found. R. W. H.

Random Radiations

By
"DIALLIST"

Better Television Fare

MY recent criticisms of the television programmes were so strongly backed up by several of the lay papers that action was taken by the authorities much more quickly than is usually the case. There was a definite and immediate attempt to brighten up the Alexandra Park transmissions and to make the evening items less of a repetition of those given in the afternoon. For these improvements, much thanks! The programmes are certainly better, but I'm not convinced at all that we are yet working on the right lines. I stick to it that, if television is to become the great popular hobby that it deserves to be, it must be able to give us entertainment of a kind that we can obtain in no other way. Or, perhaps, entertainment that we cannot have otherwise so easily and so cheaply. That is what broadcasting has achieved in its particular line. By no other means could you hear with so little trouble and at such small expense the world's best singers and instrumentalists, the finest orchestras or the most eminent men and women in scores of fields.

A Broadcasting Parallel

How can television achieve something similar in its own way? First and foremost, it mustn't try to ape the cinema. Those who devise the television programmes must bear in mind that almost everyone goes pretty frequently to the "flicks," and that there's little attraction about paying a lot of money for apparatus that will show you mainly what you can see at any picture house. Broadcasting had a very similar problem in its early days; it had to discover how to do something that the gramophone couldn't do. In some ways its task was easier: a supply of records sufficient to provide even a single week's varied entertainment during the evenings would have cost quite a lot in those days, and still would, for that matter. Then the wireless set, even in the infancy of broadcasting, enabled its owner to obtain alternative programmes at will from several different stations. Broadcasting makes judicious use of the gramophone record as a valuable aid; but those who developed it were quick to discover that the real value of broadcasting lay in the fact that with its aid millions of listeners could hear instantly and simultaneously music or the spoken word sent out from concert hall or studio. It had thus all kinds of adaptations that were beyond the powers of the gramophone.

A Line of its Own

Working on these lines, oughtn't we to try first of all to discover what desirable ends can be achieved by television and not by the cinema. First of all, I'd place news. The theatre news reels run for three days as a rule. With television we could have an up-to-the-minute illustrated news bulletin once a day. Next, big public and sporting events. These could be televised direct by means of the electron camera and the mobile transmitter with radio link if the times were suitable; otherwise, they could be filmed and sent out later on. Think of the excitement of hear-

ing H. B. T. Wakelam on a Rugger International, or Howard Marshall on a Test Match, or R. C. Lyle on the Grand National, and of being able to see what they were describing. That *would* be worth paying for! Then there are famous entertainers whose effects depends not a little on make-up, facial expression and gesture. Some of them are severely handicapped by the limitations of "sound" broadcasting; on the television screen they can come into their own. Many speakers, too, would gain a lot if they could be seen as well as heard. These are just a few rather disjointed ideas,

WHERE THE PUBLIC CAN SEE TELEVISION DEMONSTRATIONS

Place.	Particulars.
Science Museum, South Kensington.	Free.
Waterloo Station.	Free to railway ticket holders (Southern).
Army & Navy Stores, Ltd., 103, Victoria St., S.W.1.	Free.
John Barker & Co., Ltd., High St., Kensington, W.8.	Demonstrations shortly.
John Barnes & Co., Ltd., 191, Finchley Road, N.W.3.	Free demonstrations from time to time.
Barries Radio (London) Ltd., 91, Ruislip Rd., Greenford, Middx.	Free at 9 p.m.
Bensteds, 22, Hill Street, Richmond.	Free at 3 p.m. and at 9 p.m., by appointment.
Beantalls, Kingston-on-Thames ...	Demonstrations shortly.
Bon Marché, Brixton, S.W. ...	Free demonstrations from time to time.
J. B. Cramer & Co., Ltd., 46, Moorgate, E.C.2.	Free.
Electrico (Croydon) Ltd., 97, George St., Croydon, and 30, Market Square, Bromley.	Free from 3-4 p.m. and from 9-10 p.m. by appointment.
Eric Rivers-Smith, Ltd., 21, Heath Street, Hampstead.	Free.
A. W. Gamage, Ltd., Holborn, E.C.1.	Free.
General Electric Co., Magnet House, Kingsway, W.C.2.	Free.
Gramophone Co., Ltd., 98-108, Clerkenwell Rd., E.C.1.	By arrangement with local H.M.V. dealer.
Hampton & Sons, Ltd., Pall Mall East, S.W.1.	Free from 3-4 p.m.
Harrods Ltd., Brompton Rd., S.W.1.	Free.
Hendon Motor Co., 48, Vivian Ave., Hendon Central, N.W.4. (not far from Hendon Central Underground).	Demonstrations daily from 3-4 p.m., and by appointment only from 9-10 p.m.
H. Holdron, Ltd., Rye Lane, Peckham, S.E.15.	Free demonstrations from time to time.
A. Imhof, Ltd., 112, New Oxford St., W.C.1.	Free.
H. Jenks, Ltd., 54, Ebury St., S.W.1.	Free.
Jones Bros. (Holloway), Ltd., Holloway Road, N.7.	Free demonstrations from time to time.
Keith Prowse & Co., Ltd., 159, New Bond Street, W.1.	Free.
Murdoch, Murdoch & Co., 463, Oxford St., W.1.	Free, by invitation.
Pratt's, 210, High Road, S.W.16.	Free demonstrations from time to time.
Pye Radio, Ltd., Africa House, Kingsway, W.C.2.	Free, by appointment.
Quin & Axtens, Brixton Road, S.W.9.	Free demonstrations from time to time.
E. Rogers & Sons, Ltd., 56, 58 & 64, High St., Weybridge.	Free.
Royal Arsenal Co-operative Society, Ltd., various branches in S. London.	Free.
Selfridge & Co., Ltd., Oxford St., W.1.	Free. Appointments have to be booked.
The Teleradio Co., 157, Fore St., N.18, and 497, High Road, Bruce Grove, N.	Free. Names have to be left in advance at various branches of the Teleradio Company.
Trewin Bros., Ltd., Queens Road, Watford.	Free demonstrations from time to time.
Thomas Wallis & Co., Ltd., Holborn Circus, E.C.1.	Free.
Wm. Whiteley, Queen's Rd., Bayswater, W.2.	Free.
Wyater-Blyth and Tracy, 5, High Street, Pinner.	Free, by appointment, 9-10 p.m. except Wednesdays.

but they may serve to show how television entertainment could be developed on lines of its own if the money is available. And there, perhaps, is the rub.

Those Sunspots

THE big sunspots that have been in evidence for some days prior to the writing of this note have attracted a great deal of attention from the man in the street. Several of the uninitiated have asked me whether they did not portend violent weather disturbances and interference with radio. This general interest is due apparently to the fact that in the ordinary way neither Mr. or Mrs. Everyman ever sees a sunspot, and so regards them as rare and awesome phenomena. Since the sun has been shining of late (when it has shone at all) through a veil of mist, it has been quite easy to stare it in the face; hence the spots, being largish, have been readily visible to any who cared to look at them. So far I haven't noticed any dire effects. Atmospheric haven't been serious even on the long waves, where they are usually at their worst when they are about. But short-wave reception, particularly on the 19-metre band, has been extremely good. As I write W2XAD is coming in with remarkable steadiness and so strongly that the manual volume control knob is turned less than half-way towards the "full on" position.

Worth Reading

I WONDER if you've come across that remarkable book, "Mathematics for the Million?" It was written by a mathematician, Mr. L. Hogben, to wile away the time during his convalescence after a long illness, and it is obvious that he thoroughly enjoyed writing it. And whether you're mathematically sound or wish that it hadn't been such a dry-as-dust subject when you were at school, you'll enjoy reading it. In my school-days I never could see the *meaning* of mathematics; the study of the subject seemed to entail chiefly the drudgery of working out absurd problems of kinds that you were never likely to meet in actual life. You remember those ridiculous ones about the pipes that filled cisterns and when the hands of a clock were exactly at right angles? What Mr. Hogben does is to show that mathematics is simply another form of language, and that it is directly applicable to all kinds of practical problems in the life of to-day. He takes you almost without your knowing it through the complexities of trigonometry, logarithms, graphs and the calculus. If you're one of those who shy like a frightened horse at sight of an equation in a wireless article, this book will soon alter your outlook.

Looking Back

THE other day a friend asked me round to look at a twelve-year-old set that he had unearthed from his lumber room. Its appearance moved us to mirth; we were

Random Radiations—

moved to still greater mirth when, at my suggestion, we connected it up and got it into action. The local high-power stations are only fifteen miles away as the crow flies, and its "selectivity" proved just not sufficient to separate them until we had rigged up a wavetramp. Once that had been done, there was plenty of volume from the loud-speaker horn (yes, *horn*); but the quality was such that we asked each other, as man to man, how I could ever have said to him, as I did a dozen years ago when I first heard it, that it was pretty near perfection; how, indeed, either of us could have stood it for five minutes without feeling green about the gills. And when you think that the transmissions in that set's youth were nothing like what they are to-day in fidelity, you'll agree that wireless old-stagers must have been made of pretty tough stuff.

. . . And Ahead

The weird appearance of this funny old set, its multiplicity of controls (three tuning variable condensers, one reaction condenser, five filament rheostats, two potentiometers and quite a few other things), its quaint cabinet, its trailing wires, its size and its appalling quality started a train of thought. If we laugh now at the sets of a dozen years ago, it's pretty certain that a dozen years hence those we now use will seem almost equally ludicrous; what is there about them that will give rise to smiles and exclamations? I think they'll seem enormously large for just broadcast receivers to the listener of 1948. By that time I predict that the standard set will be a television receiver (though I don't fancy it will contain a cathode-ray tube. The bulk of "local" listening will be done on the ultra-short waves, and valves of acorn size will be usual. The quality, owing to the

The Simplest Mains Set

Headphone Receiver for Home-Generated DC Supply

By DAVID SYMON

THE "Grid," slowly spreading its tentacles over the countryside, reached our village at last, and it was not long before the battery receivers of one kind and another which had served me faithfully since the earliest days of broadcasting gave place to a thoroughly up-to-date mains set.

This process was taking place in almost every house and cottage round about. Battery receivers were at a discount, and I was just preparing to consign my old and faithful servants to the rubbish heap when a friend called on me.

He lives in a big old house at the end of a long lane, and he had not "gone over" to the mains for two very good reasons. The cost would have proved staggering and, furthermore, he has a very efficient and modern lighting plant. His errand on this occasion was to ask me

a 50-volt one-valve mains set? Loud-speaker output was not required, and a triode valve as a leaky-grid detector would work rather better on 50 volts than on something higher. After a few moments' thought I sketched out the theoretical circuit shown here, and then came the question of translating it into components.

One of my discarded battery sets provided a reasonably modern dual-wave aerial coil, a first-class variable condenser, a reaction condenser and the necessary grid-condenser and leak. My chief problem was to provide some reliable and permanent method of breaking down 50 volts to the proper filament voltage, and I finally decided to use one of the old DE8LFs, a sample of which somehow had survived, almost unused, from 1927. A standard wire-wound 400-ohm potentiometer proved, on a prolonged test, to be

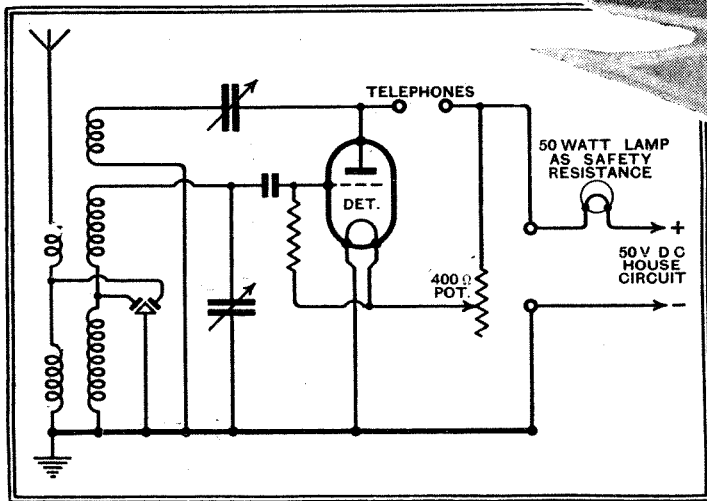
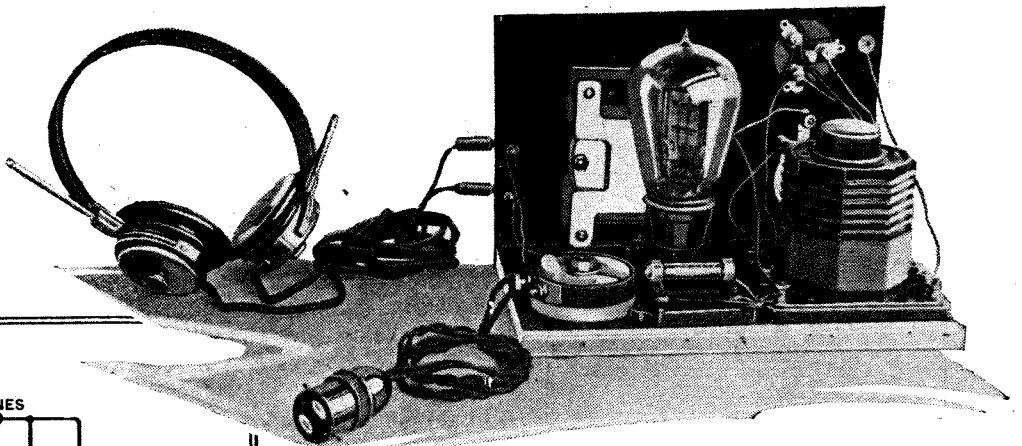

Both HT and LT currents are obtained from the low-voltage house-lighting plant.

Could anything be simpler than the circuit diagram? Smoothing equipment is unnecessary.

just capable of carrying 0.12 amp. continuously. On assembly and test, coupled to an outdoor aerial, we found that the set gave excellent results.

A modern 2-volt, 0.1 amp. battery valve might, of course, be used instead of the obsolete DE8LF, but it would require (on a 50-volt supply) a "breaking-down" resistance of nearly 500 ohms. However, that is not an insuperable objection.

The photograph shows the extreme compactness which it was possible to attain. When arranging the receiver in a cabinet, however, I decided that it would be wise to provide protection against accidental short-circuits. As a suitable lamp happened to be handy, it was inserted in circuit in the position shown, but any other kind of fuse with the appropriate rating would do as well.

Cookie nowadays has learnt the joys of "DX." No longer content with National or Regional, she often tunes in a concert from Hamburg or Stuttgart or Rome. And on these she has a stock comment—"The man talks a bit funny, but they *do* play their music lovely."

huge band of frequencies that can be dealt with, will *really* be very near perfection. Some sets may cover only wavelengths between 5 and 50 metres, medium and long-wave broadcasting being little used. There won't be such a thing as a battery set at the Show. Only one knob will appear on the radio set of a dozen years hence, for wave-change switching will be automatic, and a manual control will be unnecessary, since the set, when installed, will be adjusted to give the desired volume level on all stations. Well, there are my predictions, and if you want a fine chance of hurling the epistolary brick, file this number of *The Wireless World* and write to me in December, 1948, to tell me how wrong it proved to be!

whether I felt like helping him to make a one-valve set for use by his elderly and competent cook. She did not, he explained, like loud speakers, and had been very happy with a crystal set in her domain, but deafness was increasing and she needed a somewhat louder headphone signal for really comfortable listening. Could I suggest a circuit and specify the accumulator and HT battery which he would have to get?

At that moment came inspiration. Here was I, just released from the tyranny of batteries, there was my friend with 50 volts of clean DC available—why not

Interference from Television

A SIMPLE CURE DESCRIBED

By F. R. W. STRAFFORD (Research Department, Belling and Lee, Ltd.)

THE advent of the television service has unearthed a very unfortunate, and probably quite unforeseen, source of interference with broadcast reception on other wavelengths.

The interference is confined to a radius of approximately three miles from the television transmitter, and is characterised by the following effects:—

On medium and long waves the sound broadcast, together with a fluttering, low-pitched note of varying intensity due to

Fig. 1.—Typical input circuit, of which the selectivity curve over a comparatively narrow range of frequencies in the normal broadcasting spectrum is given in Fig. 2 (below).

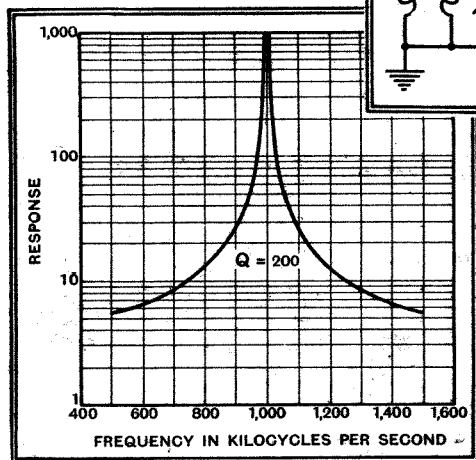

the framing impulses on the vision channel may be heard at all settings on the tuning dial. On short waves, from, say, 16 to 60 metres, the interference may possibly be independent of the dial setting, but is usually tunable at certain points on the waveband. A tunable interference is always tolerable if the tuning of maximum interference and the wanted programme do not coincide, but the type of interference which persists at all dial settings is quite intolerable.

There are several reasons why this interference is to be expected. In the first place, the technical requirements for efficient short-wave broadcasting call at present for a transmitter located as near as possible to the centre of a densely populated area, and so a number of listeners are likely to live under the shadow of the station. Thus, more persons are naturally subjected to the possibility of interference than in the case of normal broadcasting, where stations are remote from centres of population.

Secondly, it is not difficult to under-

stand why a signal of a given field strength on the ultra-short wavebands should produce more interference to medium- and long-wave reception than a signal of equal field strength located in the normal broadcast bands.

The reason is quite clear. The electrical selectivity of a tuned system does not necessarily increase *ad infinitum* as the frequency of distune increases. For example, a tuned circuit at 1,000 kc/s (300 metres) might attenuate a signal at 1,500 kc/s (200 metres) one hundred times or more. The attenuation to a signal of 45 megacycles (7 metres) might be only two to one.

This apparent inconsistency may be readily explained by reference to the elementary circuit of Fig. 1.

Assuming that such a circuit is tuned to 1,000 kilocycles, the selectivity curve would look

very much like that depicted in Fig. 2. Note that the curve is only drawn over a relatively small band of frequencies.

Now, at ultra-high frequencies, the circuit of Fig. 1 does not apply. The geometry of the coils for coupling and tuning is such that they cannot be regarded as simple inductances. In fact, they are rather more like simple capacities. The tuning condenser is possibly behaving as a condenser and inductance in series, since one must include the inductance on the wires joining the condenser to the coils. The circuit redrawn in terms of its behaviour at ultra-high frequencies looks very much like that depicted in Fig. 3.

Widespread Interference

Under these circumstances it is thus essential to draw the selectivity curve over a much wider range of frequencies. Hence Fig. 4 shows what might be reasonably expected in the simple case which has been outlined. This indicates that, while selectivity is maintained over a wide range of frequencies, it does not hold indefinitely because the simple circuit is in reality a complicated band-pass structure in which certain factors have been neglected.

Having indicated the lack of selectivity when subjected to ultra-short waves of a typical input circuit, designed for use on medium waves, it thus becomes clear that a television signal may possibly *ride through* all the tuned circuits of the receiver with little or no attenuation, and actuate the detector valve, thus producing interference. In these circumstances the

THE author explains why listeners in the neighbourhood of Alexandra Palace are subjected to interference on broadcast wavelengths, and describes a simple and inexpensive method of overcoming the trouble.

interference cannot be tuned out. Adjustment of the variable condenser may decrease the effect, but no actual resonance can be produced. The interference in this case is superimposed upon every transmission.

This type of interference is usually encountered in sets of the simple tuned RF type, and the majority of the complaints received come from users of such receivers.

Oscillator Harmonic Beats

Superhets, however, are not completely immune, and in the few cases observed the interference is tunable at certain points on the bands. These points occur when the oscillator frequency of the superhet is such that one of its oscillator harmonics beats with the television transmission to produce the intermediate frequency of the receiver. The normal processes of amplification and second detection then occur, and the interference is thus brought to the loud speaker, together with the normal programme.

At first sight it would appear that a simple resonant wavetraps tuned to the interference would be satisfactory, but, since the interference comes in at two different frequencies (the vision and sound channels of the television transmission), two wavetraps in series, one tuned to 41.5 megacycles, and the other to 45 megacycles,

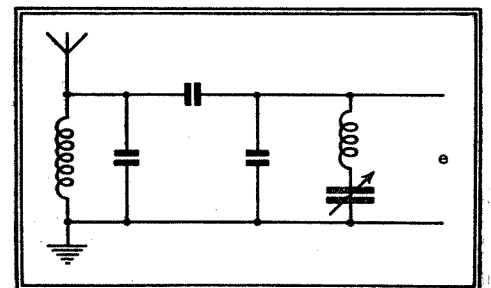

Fig. 3.—A normal circuit becomes very much like this, so far as its behaviour at ultra-high frequencies is concerned.

would be necessary. This method is expensive, and also involves rather difficult adjustments. Furthermore, it appears that such wavetraps might in certain cases have to be included in the earth as well as the aerial leads of the receiver, and possibly part of the wiring of the chassis.

Fortunately, such a complicated and expensive procedure is usually unnecessary,



How to Make Your Own Records

EXPERIENCES OF A READER
WITH A HOME OUTFIT

THIS season of the year, with its long, dark evenings, often presents a problem as to how to occupy one's time, and also, with Christmas approaching, what novel entertainment one can present to those friends who drop in during the festivities.

With this idea in mind, I was attracted by an advertisement in this paper which I thought worth while following up, it was a "Permarec" Home Recorder. I accordingly visited the maker's studios and introduced myself, quite truthfully, as a complete novice at recording. After a short demonstration I was sufficiently convinced in my own mind that there was something in this recording business, and decided to attempt it for myself. For a small sum I acquired a recorder (7in. type) and six discs.

A satisfactory feature of this unit is that it can be attached to any radiogram by a simple three-screw fixing, and, being a straight-line tracker, a clamp fixes on the centre pin of the turntable, thus transmitting the drive through bevel gears to the screw thread; a quick-release lever allows the whole unit, apart from the base plate, to hinge up, the disc then being placed on the turntable.

Discs Employed

The particular type of disc I carried out my tests on was of metal, coated with a soft chemical compound; the needle was one specially ground, and one must take care that it is inserted in the stylus of the cutting head at the correct angle, so that the cut material is directed into the centre of the disc, as otherwise it will pack behind the needle, eventually causing it to bounce. Apart from spoiling the disc, this will very likely damage the head. Let us suppose that the correct angle has been found after one or two tests, then the proper depth of cut can be found by examining one or two grooves through a magnifying glass. When the width of the groove is slightly less than the distance between the grooves, that is the correct depth of cut. This depth can, of course, be very simply adjusted by means of a threaded weight that screws along the arm of the cutting head. These two points play a large part in the success of recordings, and as soon as they have been mastered, recording a piece of music

from wireless can be tried. First of all make quite sure that the blank disc is free from all particles of dust or grit, and then, with the turntable revolving lightly, place the cutting needle about $\frac{1}{8}$ in. from the

***T**HOUGH the writer of this article had no previous acquaintance with recorders he was able to obtain excellent results with an inexpensive outfit and an existing gramophone unit. His experiences will be helpful to other readers.*

The Permarec home recorder mentioned in the text fitted to an existing gramophone unit.

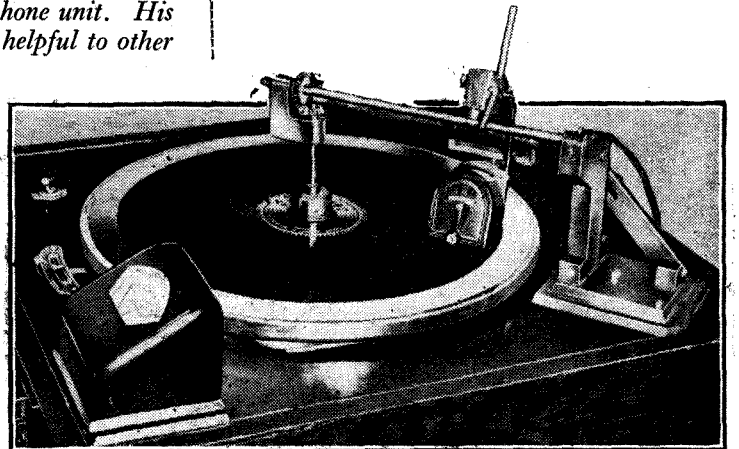

outer edge of the disc. Now, another important point presents itself—modulation or, in other words, controlling the volume of sound in such a way that no distortion or "blasting" occurs, at the same time making sure that the volume is not reduced to such an extent that the quality is impaired. It is of great assistance in correctly regulating this modulation to use a volume indicator; this is an instrument with a needle registering over a graduated scale. The average volume as indicated by this instrument that gives the best results should be noted, so that all recordings can be made at the same volume level.

The disc we are discussing now requires to be processed before it is ready for use. With a fine camel-hair brush remove every particle of waste matter from the surface of the disc, and then, taking care not to handle the surface, place it on an electric or gas oven (if necessary, special ones can be bought for the purpose), and leave it for $2\frac{1}{2}$ -3 hours at a temperature of approximately 200 deg. Centigrade. When this time has elapsed the disc becomes per-

manent, and can be played many hundreds of times. It may happen that when the record is played back for the first time the motor may slow down and stop; this, however, can be easily overcome by rubbing the surface of the disc with an oily rag, and no further trouble should be experienced. A big feature of records of this type is that they can be played with a standard loud-tone steel needle, a trailer, for preference.

So far, we have been discussing the 7in. disc, but all the above remarks apply equally to the 10in. and 12in. discs; the only difference is that the traversing

mechanism has a longer threaded screw. In many cases, however, the mere fact of using a larger disc may reveal that the existing motor is not sufficiently powerful to overcome the increased resistance, but excellent silent-running electric motors of adequate power can now be obtained at quite low prices.

Some readers may say that it is too much bother to process the records, and, being naturally impatient to hear the results of their labours, may want a disc that does not require processing. Well, there are several types from which to choose. The most satisfactory, to my mind, is the acetate one; this will give an immediate play-back with excellent results and practically no background noise, but, possessing as it does a harder surface, more weight is required on the cutting head, which can be ascertained by the same methods as described earlier, and a different type of cutting needle must be used. Coated glass is another medium used for recording, and here a sapphire needle has to be employed; aluminium discs are also

available, but with some of these types the record is not of a permanent nature.

Success will not come at first, but the results will be sufficient encouragement and inducement to persevere, the main points to watch being: (a) Depth of cut, (b) modulation, (c) thorough brushing of the soft type disc after cutting and before processing, and (d) temperature of oven. For best results the cutting needles should be changed after cutting two sides. Before cutting the second side make sure no material is adhering to the point of the needle.

When using a microphone the carbon type will be found to be perfectly satisfactory for ordinary recording purposes, and very good ones can now be obtained at quite low prices.

News from the Clubs

The Wrral Amateur Transmitting and Short-wave Club

The usual monthly meeting was held recently at King's Square Café, Birkenhead, when there was a junk sale and a raffle. The next meeting will be on Wednesday, January 6th, 1937. Hon. Secretary, Mr. B. O'Brien Caldly, Irby Road, Heswall.

The Exeter and District Wireless Society

At a lecture by E. H. Ware, a demonstration was given of *The Wireless World* holiday portable receiver, which proved to have a total HT consumption of only 2½ milliamps. Even in Cornwall the National programme from Droitwich was received with great strength. The Ferguson all-wave receiver, giving an output of 8 watts, was also demonstrated. Mr. Stanley Brown, A.M.I.E.E., lecturing recently on the manufacture of accumulators, emphasised the extreme accuracy—less than half of

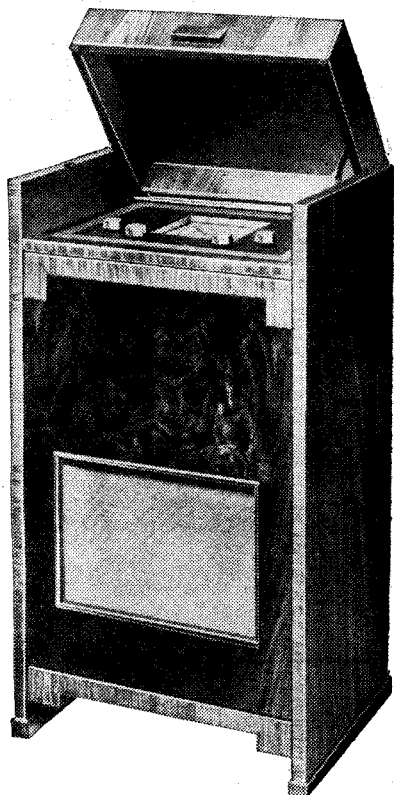

McMichael Model 362 in console form.

one per cent.—of the charge indicator-clock now incorporated in a large number of commercial cells. The society meets every Monday at No. 3 Dix's Field, Exeter, and those interested are asked to get into touch with the Hon. Secretary, Mr. W. J. Ching, Sivell Place, Heavitree, Exeter.

The International Short-wave Club

The London Chapter of the above organisation is giving a special demonstration of television reception in the R.A.C.S. Hall, Cavendish Grove, Wandsworth Road, S.W.8 (near Vauxhall Station, S.R.), at 8.30 p.m. on Friday, December 18th. The Chapter will be pleased to let readers have tickets if they will forward a 1½d. stamp to Mr. Arthur E. Bear, 100, Adams Gardens Estate, S.E.16.

The Harco Radio Club

Most of the members of this club are interested in short-wave adaptors, and for this reason morse code instruction is one of the leading features of the club. Meetings are held in the canteen lounge of G. A. Harvey and Co., Ltd., Woolwich Road, Charlton, S.E.7, at 7.30 p.m. every Tuesday, and not Thursday as previously announced. *Wireless World* readers are invited to attend any of these meetings. The secretary will be pleased to forward full details if a postcard is sent to him at Department HRC, 124, River Way, Greenwich, S.E.10.

The Croydon Radio Society

At a recent meeting of the above club a well-known music critic gave an entertaining lecture entitled "The Emotional in Music." He explained the difference between real emotion and the superficial sentiment expressed by the crooners, with whom he sympathised, as their efforts denoted certain sad forms of mental disease well known to the medical profession. The Hon. Publicity Secretary, Mr. E. L. Cumbers, 14, Campden Road, South Croydon, invites enquiries concerning the society's activities.

The Radio Society of Northern Ireland

This society, which has been in operation for over two years, has now a total of more than fifty members, including twelve transmitters. The society holds meetings on the first Wednesday in each month in the City of Belfast Y.M.C.A. Radio Club Room, Wellington Place, Belfast. A new rotary converter has been installed at the club's station, and soon its call sign, GI6YM, will be heard on the air and reports will be welcomed. Full details concerning the activities of the society may be obtained from the Hon. Secretary, 46, Victoria Avenue, Sydenham, Belfast.

McMichael All-Wave Console

THE Model 362 all-wave chassis is now available in a console cabinet in which a note of originality is provided by the sunk lid. The panelling is in figured walnut, and the loud speaker surround is of oxidised copper.

There are three waveranges, including a short waveband from 18.6 to 51 metres, and the tuning dial carries a subsidiary "band spread" pointer. The triode-pentode frequency-changer is preceded by a pentode RF amplifier, and followed by a single-stage IF amplifier and a double-diode-pentode combined detector and output valve.

The receiver is designed for AC mains, 200-255 volts, 40-100 cycles, and the price is 17½ guineas.

POINTS OF IMPORTANCE

in the Rola G.12

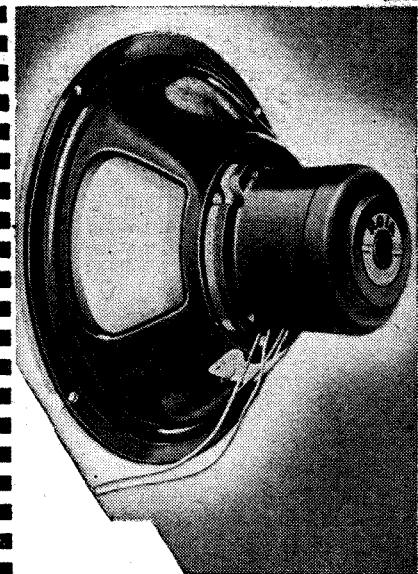

A1 AT LLOYD'S

A1 at Lloyd's is accepted by all as an unchallengeable guarantee of the sea-worthiness of a ship. To the real radio enthusiast "G.12 equipped" is just as assuredly a guarantee of the air-worthiness of a set. The Rola G.12 is a 12in. diameter, high fidelity, unit of unsurpassed tonal quality. Its very presence in a radio receiver indicates that the manufacturer has put quality first throughout. That the public has been quick to discover this is proved conclusively by manufacturers' sales curves of G.12 equipped sets this season. Ask for a demonstration without delay.

G.12 D.C. (as illustrated) Stripped and without Transformer ...	£3 15 0
G.12 D.C. Complete with Transformer, Mounting Stand, Handle and Base ...	£5 5 0
G.12 D.C. with Mounting Stand, Handle and Base, but without Transformer ...	£4 16 0
G.12 D.C. Stripped, but with Transformer ...	£4 4 0
(When ordering please state Field Resistance and Impedance of Transformer required.)	
G.12 P.M. less Transformer ...	£4 16 0
G.12 P.M. with Transformer ...	£5 5 0

For Public Address work both the P.M. and Energised Models can be supplied with a 15 ohm Voice Coil at an additional charge of 3/-.

Write for Folder A.

OVER 7 MILLION IN USE

ROLA

The World's Finest Reproducers

THE BRITISH ROLA CO., LTD.
MINERVA ROAD, PARK ROYAL, N.W.10.
PHONE: WILLESDEN 4322-3-4-5-6.

Brief descriptions of the more interesting radio devices and improvements issued as patents will be included in this section.

Recent Inventions

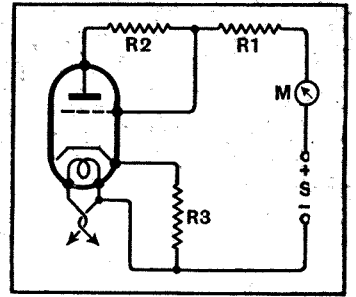

Emission tester for thermionic valves.

voltage source of alternating or direct current. Resistances R1 (2,000 ohms) and R2 (3,000 ohms) are connected as shown, the latter being tapped to the grid. The resistance R3 is only required in the case of an indirectly heated filament.

The source S drives a current through the circuit which is measured by M, its value for a given voltage being dependent on the emission from the filament. In practice the applied voltages are found to be automatically regulated, by the resistances shown, for various types of valves, and so tend to give a standard reading on the meter so long as the emission is good. When the emission falls off, the internal valve-resistance increases relatively to the external resistances, the automatic current-equalising action no longer holds good, and the meter reading falls below the standard.

E. R. Sawyer. Application date March 11th, 1935. No. 453167.

TUNED CIRCUITS

A RESONANT unit consists of a coil, an odd number of quarter-waves long, enclosed in a conducting cylinder which provides the distributed capacity. The cylinder is slotted longitudinally, and the coil is fitted with a ferromagnetic core. The two together form an artificial line with high impedance at one end and low at the other. The unit may be used to back-couple the plate and grid of a valve, or as an interstage coupling with a band-pass characteristic.

Marconi's Wireless Telegraph Co., Ltd., and N. M. Rust. Application date March 16th, 1935. No. 453842.

LOUD SPEAKERS

IN order to prevent dust from getting into the airgap of a moving-coil speaker, the diaphragm is fitted to a tube carrying the driving-coil, and a dust-proof cap is fitted snugly into the mouth of the tube. The cap is preferably made of cellophane or other transparent material, so as to facilitate the proper centering of the driving-coil.

E. K. Cole, Ltd., and A. E. Falkus. Application date June 19th, 1935. No. 451984.

mission line for coupling the valve to a transmitting or receiving aerial.

The magnetic field from an external winding constrains the free path of the electrons in the way usual in the magnetron type of valve.

Marconi's Wireless Telegraph Co., Ltd. (assignees of E. G. Linder). Convention date (U.S.A.) 2nd July, 1934. No. 453243.

AUTOMATIC TUNING.

RECEIVERS are now being provided with means for automatically correcting any initial mis-tuning of the circuits, so as to prevent the distortion which would otherwise occur when the set is worked "off resonance." Usually, the correcting circuit tends to come into operation whenever the incoming signal combines with the local oscillation to produce a "false" intermediate frequency, and it continues its work until the "false" frequency has been converted into the true intermediate frequency. When this is the case the circuits are correctly tuned.

guard plate, or electrode G, which is designed to prevent any secondary electrons produced by the impact of the "jet" stream on the anode from getting back into the lower part of the valve. The guard plate extends right across the glass tube and is fitted with side walls S, the discharge jet passing through a small aperture at its centre.

Marconi's Wireless Telegraph Co., Ltd., G. M. Wright, G. F. Brett, and N. M. Rust. Application date March 4th, 1935. No. 453137.

CATHODE-RAY RECEIVERS

THE picture is reproduced, not by fluorescence as usual, but by causing the electron stream to impact against a very thin sheet of tungsten or tantalum which has previously been heated to a point just below incandescence, the effect of the bombarding electrons then being sufficient to produce clear-cut visible effects by the extra heat they produce.

The metal screen S is shown in the figure end-on, facing the elec-

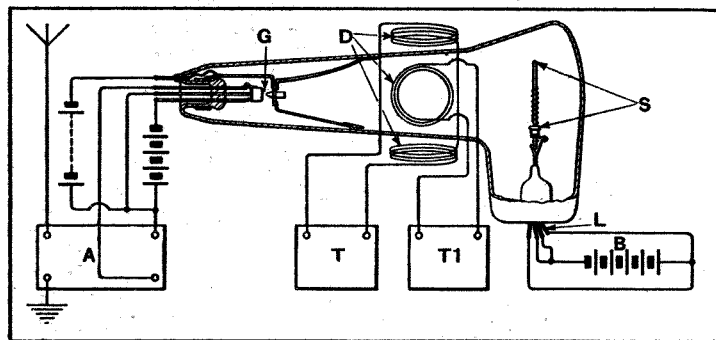

Cathode-ray tube for projecting image on to an external screen.

tron stream from the "gun" G of the cathode ray tube. The current required to keep the screen just below the glow-point is provided through leads L and a battery B arranged at one side of the flared end of the bulb. The usual deflecting or scanning coils are shown at D, and are connected to time-base circuits T, T1, the incoming television signals being applied through an amplifier A. The image produced in this way on a screen 2in. square is said to be so brilliant that it cannot be viewed directly. But when projected through lenses, it will give a clearly-defined picture up to five feet square.

F. S. Turner. Application date February 15th, 1935. No. 452368.

A VALVE FOR MICRO-WAVES

A VALVE capable of generating and amplifying waves a few millimetres in length is of the split-anode type, the two anodes being formed by the opposite faces of the segment of a ring. Actually a hole is drilled longitudinally through the wall of a thick ring, and the filament is placed inside. The leading-in wires for the anode are continued outside the glass bulb, and act as a trans-

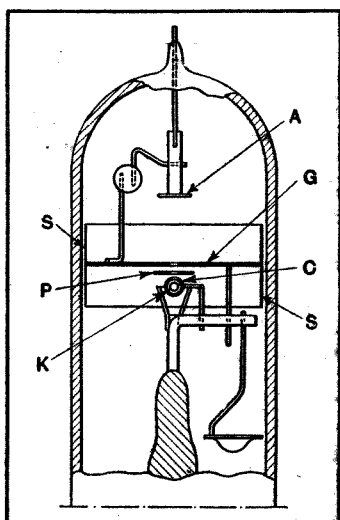

Electrode assembly in the "beam" valve.

The British abstracts published here are prepared, with the permission of the Controller of H.M. Stationery Office, from Specifications obtainable at the Patent Office, 25, Southampton Buildings, London, W.C.2, price 1/- each. A selection of patents issued in U.S.A. is also included.

The Wireless World

THE
PRACTICAL RADIO
JOURNAL
26th Year of Publication

No. 903.

FRIDAY, DECEMBER 18TH, 1936.

VOL. XXXIX.

No. 25.

Proprietors: ILIFFE & SONS LTD.

Editor:
HUGH S. POCOCK.

Editorial,
Advertising and Publishing Offices:
DORSET HOUSE, STAMFORD STREET,
LONDON, S.E.1.

Telephone: Waterloo 3333 (50 lines).
Telegrams: "Ethaworld, Sedist, London."

COVENTRY: Hertford Street.

Telegrams: "Autocar, Coventry."
Telephone: 5210 Coventry.

BIRMINGHAM:

Guildhall Buildings, Navigation Street, 2.
Telegrams: "Autopress, Birmingham."
Telephone: 2971 Midland (4 lines).

MANCHESTER: 260, Deansgate, 3.

Telegrams: "Iliffe, Manchester."
Telephone: Blackfriars 4412 (4 lines).

GLASGOW: 26B, Renfield Street, C.2.

Telegrams: "Iliffe, Glasgow." Telephone: Central 4857.

PUBLISHED WEEKLY. ENTERED AS SECOND
CLASS MATTER AT NEW YORK, N.Y.

Subscription Rates:

Home, £1 1s. 8d.; Canada, £1 1s. 8d.; other
countries, £1 3s. 10d. per annum.

*As many of the circuits and apparatus described in these
pages are covered by patents, readers are advised, before
making use of them, to satisfy themselves that they would
not be infringing patents.*

CONTENTS

	Page
Editorial Comment	635
Contrast Amplification: A New Development	636
Pentodes and Loud Speakers	639
Current Topics	641
Haynes Radio Television Equip- ment	642
Unbiased	648
Imperial Transportable	649
Random Radiations	650
Letters to the Editor	651
Listeners' Guide for the Week	652
New Apparatus Reviewed	654
Resistance-coupled Amplifiers	655
Broadcast Brevities	658
Wide Range Record Reproduction	659
Recent Inventions	660

EDITORIAL COMMENT

Empire Broadcasting Urgent Need of Development

THE Ullswater Committee in their Report on Broadcasting, recommended that the Empire broadcasting service should be expressly authorised and developed, and stated that they attached great importance to the service. They recommended that the additional funds required should be provided by the Corporation from its increased share of licence receipts. The B.B.C. itself expressed satisfaction with these proposals.

What, then, should be the position to-day with regard to the Empire service? We should at least expect that active steps would be taken to ensure that our Empire broadcasting should be as efficient as the long-distance short-wave transmitters of other countries. Our needs are so much greater because of the fact that the Empire extends all over the world.

The first short-wave transmitter in this country was established at Chelmsford, by arrangement with the Marconi Company, at the end of 1927. This, it will be remembered, followed a campaign of many months by *The Wireless World*, which originated the idea of an Empire short-wave station.

It is, perhaps, interesting to recall what we said at that time. We pointed out that even if we were deprived of broadcasting here, we still had other sources from which to obtain our news and entertainment, but that it was not so in distant parts of the Empire. We said then that if we delayed we should find that instead of broadcasting becoming a means of uniting the peoples of the Empire, it might become rather a menace to the Empire, for the reason that dependence upon the high-power broad-

casting stations of neighbours would increase and sections of the Empire would become subject to the influence of a national spirit which was not their own.

We should expect to lead the way in short-wave Empire broadcasting because of the start we had before any other European countries, except Holland, had made any move.

But what do we find? Few parts of the Empire are satisfied with the service by comparison with the efficiency of short-wave transmissions from other countries. The Empire broadcasting service has recently come in for considerable criticism in the Australian Press because it compares so unfavourably with the service from Germany.

Where is the Hold-up?

The Empire service boasts only two transmitters, whilst Germany already has six; with this handicap, is it surprising if the German service excels our own, and that the Empire receives its news first from a foreign source?

We know, from information which has been published in *The Wireless World*, that the B.B.C. have adequate plans prepared to improve the Empire transmission side, but why then is progress so slow? The promise has been that "by early next year" the new stations would be in operation, but anyone who has visited the site would indeed be an optimist if he thought the work could be completed "early next year" at the present rate of progress.

Surely it is time we became alive to the national importance of Empire broadcasting and ceased to stint our expenditure upon it. From a national point of view the Empire service may even be regarded as of equal potential importance to defence measures which are today receiving such urgent attention.

Contrast Amplification:

A NEW DEVELOPMENT

ALL well-known methods of volume expansion introduce a risk of harmonic distortion, which is particularly undesirable in the high-level, high-quality receivers with which "expanders" are normally used. Our contributor describes a system recently developed in America, which, it is claimed, introduces no distortion

By W. N. WEEDEN

VOLUME expansion is becoming an old story to many of us, but if all of the various schemes so far introduced or proposed are examined critically, it will be found that none is ideal. They all suffer from some shortcoming or other.

The first circuit to be used for volume expansion in America was probably that shown in Fig. 1. This was developed by the Bell Telephone Laboratories for use in the transatlantic telephone circuits. While this circuit was the first, it is still the best from an operating standpoint, although the additional transformers run the cost up too much for use in broadcast radio receivers or gramophones. One additional problem imposed by this circuit is the necessity for "matching" the two "76" valves at several points on their characteristic curves. Both tubes *must* reach cut-off, or some low value of plate current, with the same value of grid bias. Also, both should require the same grid bias in the normal operating region of 5 to 10 milliamperes. As the valves depart from a matched condition, harmonic distortion increases rapidly, due to the low-impedance anode load. In America it is difficult to secure tubes which will age at the same rate, thus necessitating frequent replacement of tubes with hand-picked substitutes, which is both an expensive and annoying procedure.

The Pentagrid Mixer

Fig. 2 is the diagram of a circuit designed by RCA around the 6L7 valve—a so-called Pentagrid Mixer Amplifier tube. This tube has two control grids, number 1 grid having a remote cut-off, while number 3 grid possesses a sharp cut-off. If a signal is applied to No. 1 grid the mutual conductance and gain may be varied over quite a wide range by varying the number 3 grid potential. This would seem an ideal arrangement, and is the one which has been used by two or three American manufacturers. If the characteristics of the 6L7 be examined carefully, it will be realised that distortion of the audio signal by the curvature caused by the remote

cut-off nature of the first grid is appreciable for large signals. Even when operated with a signal in the neighbourhood of 1 volt peak, the second harmonic distortion will lie between 5 and 8 per cent. All these tubes vary quite widely, many will be found having a sharper cut-off than the standard, and will thus cause even more distortion. Of course, much of this even harmonic distortion could be balanced out by the use of push-pull or

balanced circuits. So far, however, no one has attempted this.

A third method of volume expansion is shown in Fig. 3. Because this circuit has already been described in *The Wireless World* (Simplified Volume Expansion, April 24, 1936), little will be said here. Its advantages are simplicity and cheapness, and its disadvantages are inefficiency (waste of at least 50 per cent. of the available output power, which is usually none too great), and lack of control of degree of expansion. Also, as the level of reproduction is decreased from the standard for which the lamp bulbs were calculated,

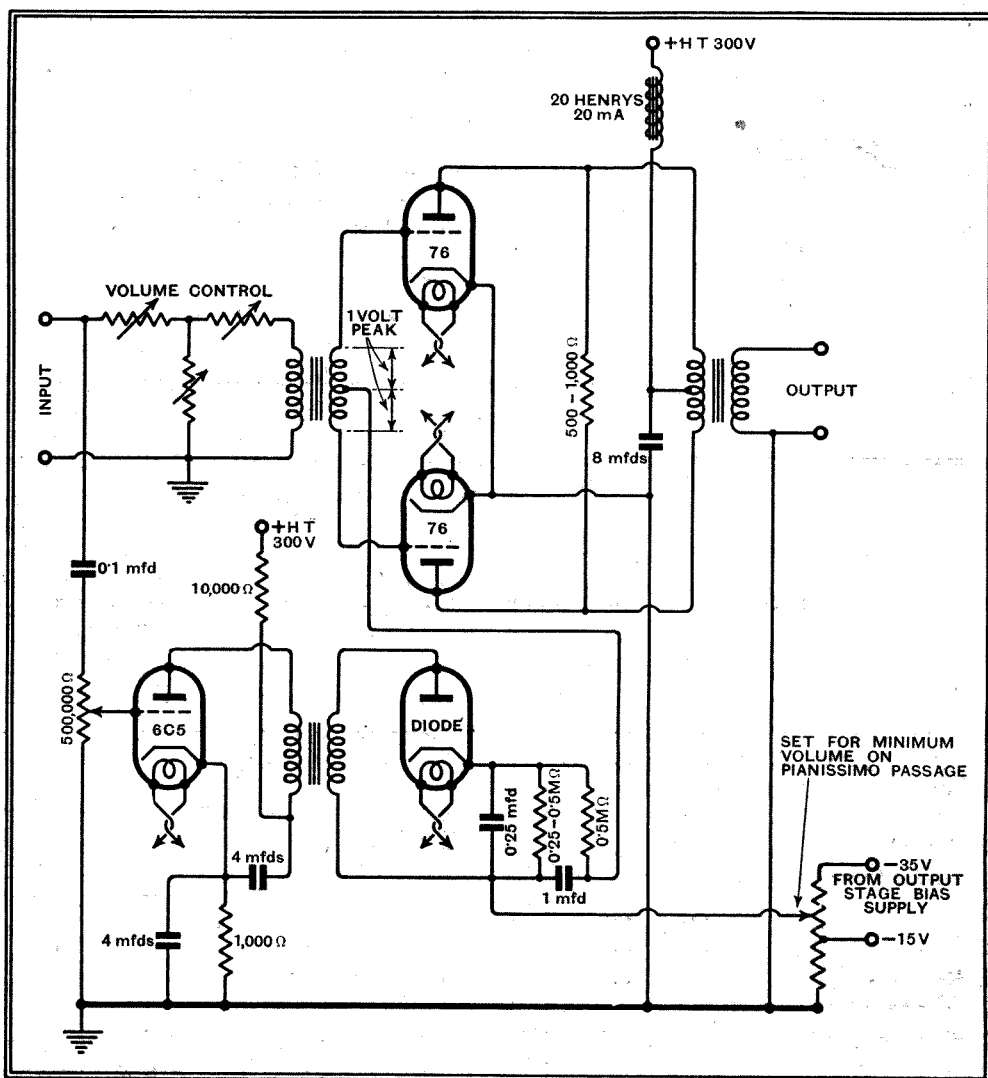

Fig. 1.—Original volume-expansion circuit, as used for transatlantic telephony.

Contrast Amplification—

the degree of expansion decreases rapidly. Thus it may be seen that this form of expander is very expensive in wasted output power and is also extremely inflexible. At the present, however, it is the only form of expander which can be added to an existing receiver or gramophone without rebuilding, and it can give some of the benefits of expansion.

Before taking up the next method, let

dance to vary from infinity to some low value. A volume expander working on this principle is shown in Fig. 6. It will be seen that such a circuit should cause no distortion, as the control valve is used only as a variable resistance, eliminating the effect of curvature of characteristics as encountered when the control valve is utilised as a variable gain amplifier. With this simple circuit, an expansion of 15-18 db. will be secured.

Continuing in the upper channel (amplifier), the signal must pass through a 0.05-mfd. isolating or blocking condenser, a 100,000-ohm resistor and a

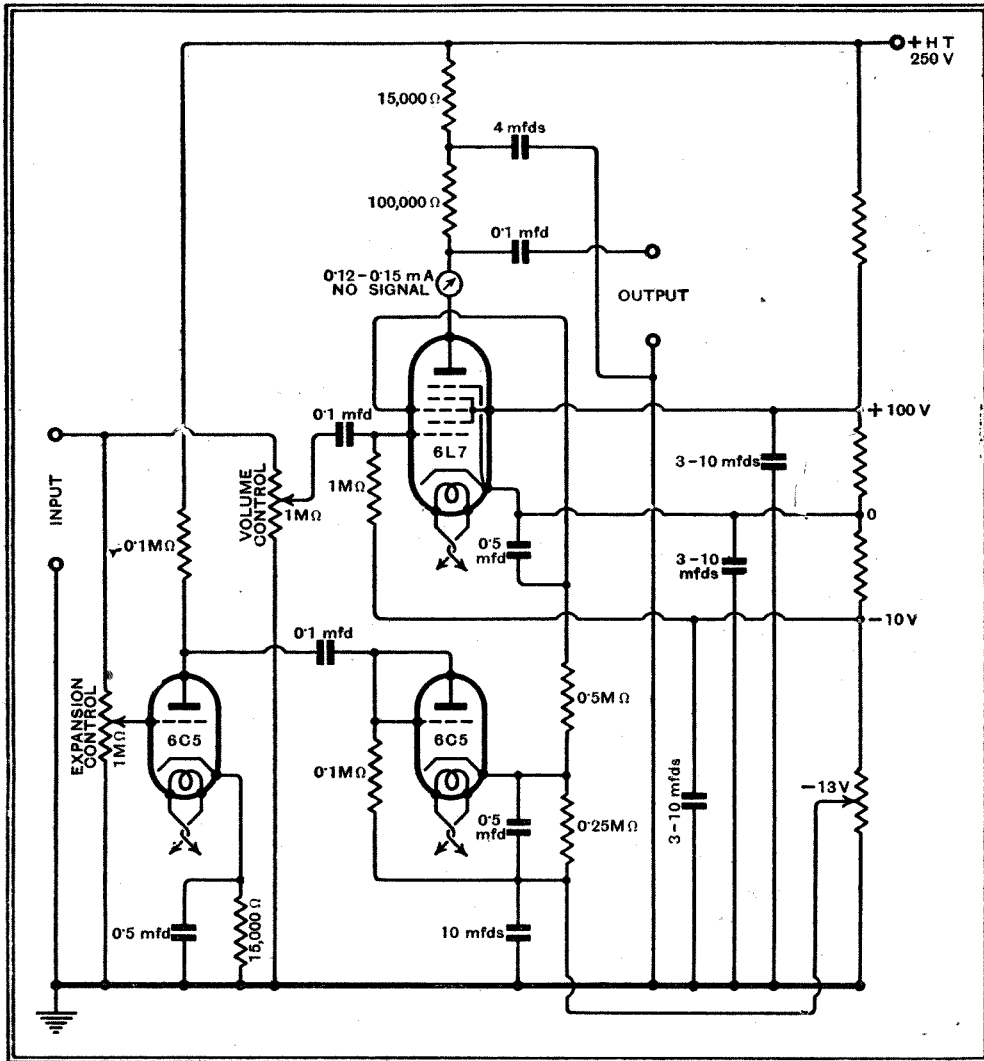

Fig. 2.—Expansion circuit developed by the Radio Corporation of America.

it be said that expansion is normally useful and desirable primarily when listening at realistic (high) levels. This implies that the power output is large, and it generally follows that the amplifier and speaker are designed to minimise harmonic distortion. For this reason, it would seem very inconsistent to use a device which may add 5 to 10 per cent. harmonic distortion. Therefore, the first criterion of an expander should be its freedom from distortion.

To proceed to Fig. 4, we see a conventional potentiometer used as an audio-frequency volume control. This can be modified to that shown in Fig. 5, where R1 remains fixed and R2 is variable. It is but a short step to substitute for R2 the plate resistance of a vacuum tube, arranging its grid so that rectified low frequency signals will vary its bias from cut-off to normal plate current, causing its impe-

A brief discussion of the action of this new expander may be of interest. In Fig. 6 the input is divided between the amplifier and the control channel, the two 1-megohm potentiometers being used to control the level and the degree of expansion. In this manner both can be set in-

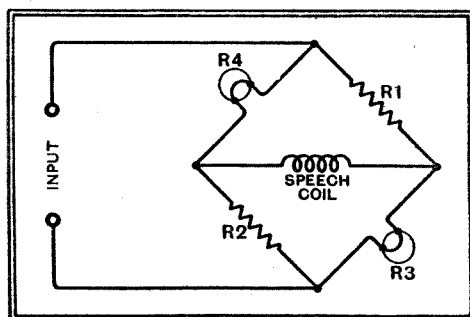

Fig. 3.—The Crosley volume expander, which needs a minimum amount of apparatus.

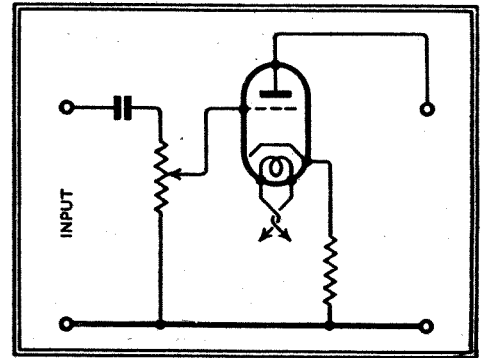

Fig. 4.—Explaining a modified system of expansion: this diagram represents a simple input volume control.

second 0.05-mfd. isolating condenser to the grid of V3, which is normally the second-stage audio-frequency amplifier. In series with the 0.1-megohm resistor is the plate-to-cathode resistance of V2, a remote cut-off pentode. This plate-to-cathode resistance is equivalent to R2 of Fig. 5, R1 being the previously mentioned 0.1-megohm resistor. The ratio of R1 to R2 is the determining factor in the signal developed on the grid of V3, and is controlled by the voltage on the control grid of V2. This in turn is equal to the voltage drop across the 0.5-megohm resistor in the plate circuit of V1, a sharp cut-off pentode, biased nearly to cut-off by the 8,000-ohm resistor in its cathode circuit, and operating as a plate rectifier. Thus with no signal on the grid of V1, its plate current is a minimum, as is the voltage drop across its plate resistor. Now if an audio-frequency signal is introduced, its plate current and the proportional voltage drop across the 0.5-megohm re-

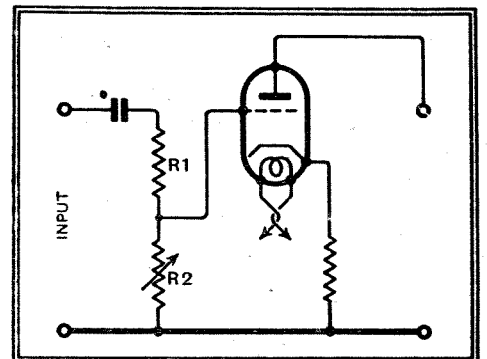

Fig. 5.—This arrangement of a fixed and variable resistance, acting as a potentiometer, is comparable with Fig. 4.

sistor will increase, making the high-potential end of this resistor more negative than with no signal. As this point becomes more negative, the control or No. 1 grid of V2 becomes more negative, increasing the plate resistance and the audio-frequency or signal voltage on the grid of V3. It will be seen that the plate voltage of V2 flows through the 0.1-megohm resistor connected thereto, and then through the 0.6-megohm and 0.1-megohm resistors—

Contrast Amplification—

all in series. The 1-megohm resistor and the 0.2- and 0.3-mfd. condensers between the plate of V1 and V2 constitute a filter to eliminate the rectified signal from the grid of V2. They also control the time constant or speed of action of the expander. The expander may be made in-

panders, which usually operate most satisfactorily with very low inputs, normally in the neighbourhood of 1 volt peak.

A last word in closing. Once an expander has been used, you will never be satisfied without one. In addition to its primary function of "volume range restorer," the expander possesses a second

stations were "there" near the last sunspot maximum, but that they were usually drowned by atmospherics. In support of this contention I may mention that in the summer of 1929, when I was recovering from a long illness, I always had a receiving set at my bedside and made frequent use of it in the sleepless small hours. On one night early in August, I logged and identified no fewer than 33 medium-wave American stations! It was a night quite free from atmospherics, and stations were to be found here, there and everywhere—despite the fact that August is usually regarded as one of the worst months in the year for DX reception.

Nowadays there are two factors which may have made all the difference. The first is that many U.S.A. stations have enormously increased their output power, so that they now have a chance of competing with, at any rate, the less violent atmospherics in signal-to-noise ratio. The second, that the superhet has come into general favour. It is much more sensitive than the average straight set, and it does not accentuate atmospheric interference so strongly as does the straight set operated close to the point of oscillation.

D. EXER.

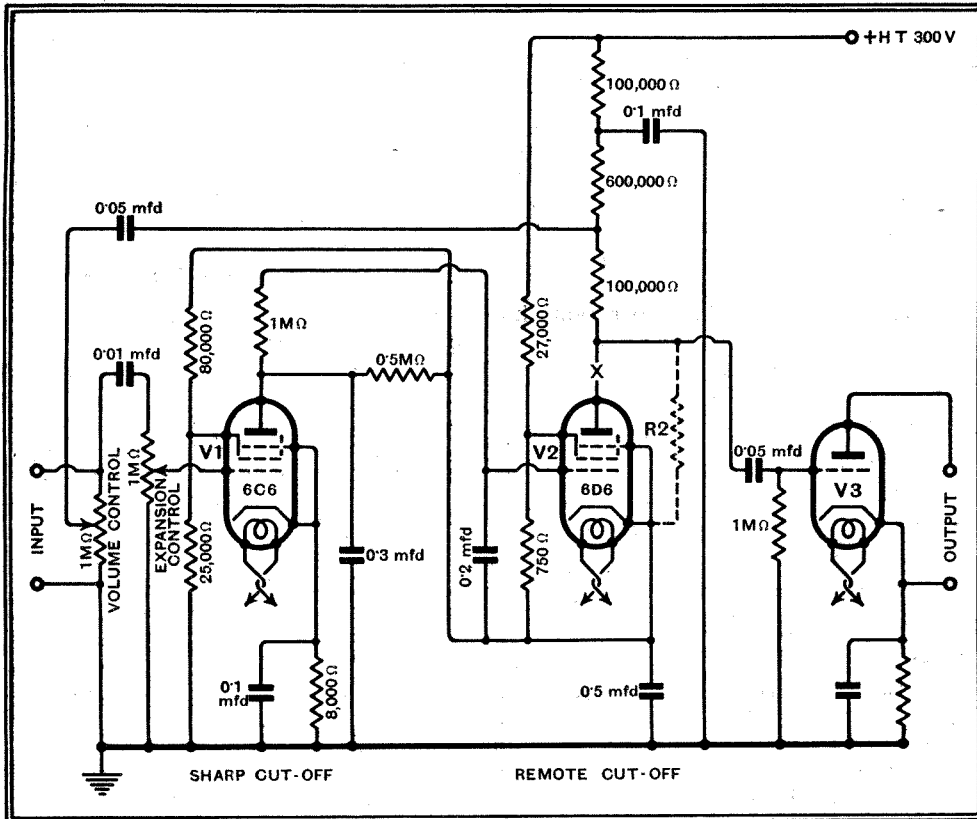

Fig. 6.—The new system of volume expansion, which works on the principle illustrated by Figs. 4 and 5.

operative simply by breaking the plate circuit of V2 at X. The input signal voltage may vary from a few volts to nearly 50 volts with little effect on the operation. This is in contrast to the action of any of the other practical ex-

virtue of almost as great importance—its ability to reduce noise (surface noise of a record; or man-made interference or static in radio reception) during soft passages of music, greatly increasing the pleasure of listening.

DISTANT RECEPTION NOTES

NOT a few people have remarked to me that it is odd, to say the least of it, that American medium-wave stations should be coming in so well just now, when we are well on our way towards a sunspot maximum. They find it particularly curious since of late a big group of spots on the sun's disc has been plainly visible to the naked eye.

The previous sunspot cycle culminated in a strange "double humped" maximum in 1927 and 1928. It was the first cycle during which sufficient detailed observations were made to enable any theories about the effects of solar activity on long-distance wireless reception to be formulated; it was also the first in which any short-wave broadcasting over great distances was attempted.

Old hands will remember that in 1923 and 1924, years in which sunspots were at a maximum, transatlantic stations were first heard in this country. So well were they received that many people heard KDKA, WGY and other stations on headphones with single-valve sets. A year or two later they had come to show so marked a decline

that "sitting up for America" ceased for the time to be a national hobby. There was a big improvement from the end of 1931 onwards, and by 1933 anyone who possessed a reasonably good set and did not mind remaining out of bed until 2 a.m. could be pretty certain of hearing America.

The short waves appeared to behave in a rather different way, improving as we neared a sunspot maximum. The earliest reception of KDKA on something over 60 metres was in 1925, and after that we had better and better results from stations on shorter wavelengths for some years.

Well, I am not at all satisfied that the decline in the strength of medium-wave American stations was entirely genuine at the last sunspot maximum. Remember that we were then all using straight receiving sets, which depended very largely upon the skilful use of reaction. And one disadvantage of the regenerative set is that it does bring out atmospheric interference to the full when you are working close to the point of oscillation.

I believe that U.S.A. medium-wave

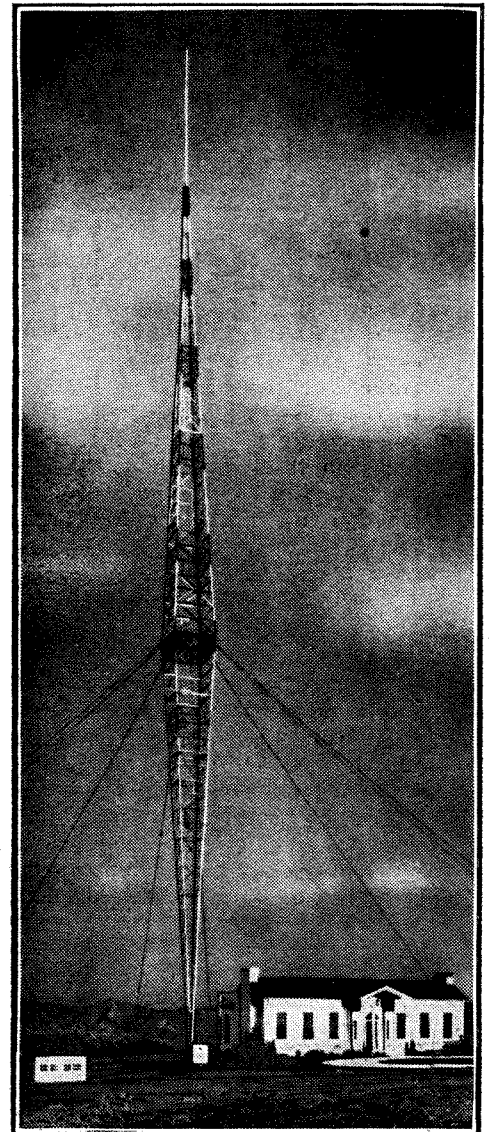

THE VERTICAL RADIATOR at WSM, Nashville, Tennessee, U.S.A., which works on 461.3 metres (650 kc/s). The station is at present rated at 50kW, but application has been made for permission to increase power to 500 kW.

Pentodes and Loud Speakers

WHY IT IS MORE DIFFICULT TO AVOID DISTORTION THAN WITH A TRIODE

OUT of a representative list of 337 receiver models on the market, 53 are specified with a triode output; the remainder employ pentodes. Pentodes outnumber triodes by more than five to one. If the total number of individual sets manufactured were made the basis of comparison the odds would be much greater, because most of the triode sets are specialised types having a comparatively small sale. In short, the pentode may be said to be the standard type of valve for working a loud speaker.

Whatever may be the reasons for this displacement of the triode from general use, nobody is likely to claim that it is on grounds of tone quality. That given by the pentode is, or can be, extraordinarily good. But it remains a fact that when loud speaker reproduction is, in certain respects, a trifle "off" (as one might say of an egg), it is still a custom to refer to it as "pentode tone." The description may be based more on the remembrance of early pentode results than those common to-day; but nobody thinks of talking about "triode tone" in any other than a commendatory sense. However good reproduction from a pentode *can* be when conditions are just right, there is still some ground for associating it with a tendency to be just a little more shrill, rough, or harsh than the best triode reproduction. And it cannot be questioned that whenever a designer turns his attention to a really high quality job, regardless (more or less) of cost, he selects a triode. And that in spite of the fact that pentodes are dearer!

Output Ratings

One may well be excused for being rather puzzled about this, because both sorts of valve are rated to give a certain "undistorted" output in watts, or more precisely a certain output not containing more than 5 per cent. harmonic distortion. For a specified HT power supplied to the valve the pentode gives a greater output; but this only thickens the mystery, for, other things being equal, the valve with the bigger reserve of power is the less likely to be driven beyond the 5 per cent. distortion limit—or any other distortion limit. For instance, supposing a certain triode is capable of giving 2 watts at 5 per cent. distortion, a pentode requiring the same feed current and voltage is likely to be good for about $3\frac{1}{2}$ watts, and presumably when it is delivering only 2 watts the distortion is less than 5 per cent. A reasonable conclusion,

then, is that the tone should be better.

Here is an apparent contradiction. One explanation is that harmonic distortion is not all of the same sort. It consists, of course, of the introduction by the valve of spurious tones 2, 3, 4, 5, etc. times the frequency of the original.

When reckoning the 5 per cent. limit the total harmonics are taken into account, regardless of the proportions in which the individual harmonics are present. In a triode stage working under proper conditions the 2nd harmonic is the most prominent. Incidentally it can be greatly reduced by using two triodes in push-pull, which is one reason why that is done in most high-quality amplifiers. Of all harmonics the 2nd is the least unpleasant. It is the octave above the original tone.

Pentode distortion, on the other hand, consists largely of 3rd and other odd-number harmonics, including appreciable proportions of quite high numbers. These contribute far more unpleasantness than the same total percentage where 2nd harmonic predominates.

That is one thing. Another is that the

of the "signal"; not the much smaller resistance to DC.)

But a loud speaker (including its transformer) is not the same thing as a pure resistance; there is some inductance to complicate matters. Combined with the resistance it comprises the *impedance*.

By "CATHODE RAY"

Even the resistance is rather indefinite, because within the range of frequency to be reproduced—say 80 to 4,000 or 30 to 10,000 c/s according to the type of set—it may vary appreciably. The effect of the inductance increases in proportion to the frequency, so the impedance as a whole rises. The question occurs then, which, if any, of these values of impedance is the one that should be equal to the "optimum resistance" for the valve?

For the triode the problem can be satisfactorily solved. The position is that any load resistance *greater* than optimum causes a reduction in output *and* harmonic distortion (Fig. 1a). The same is practically true when the impedance is not a

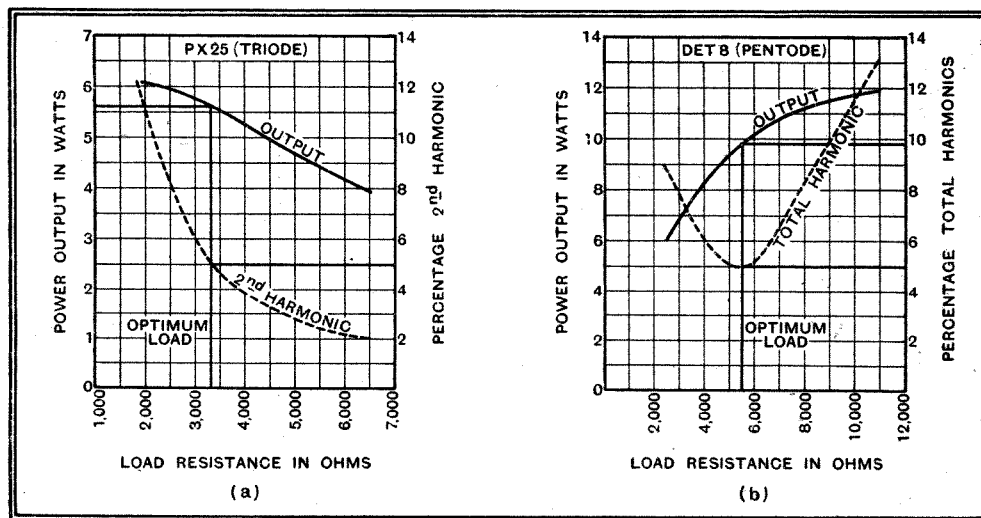

Fig. 1.—Curves taken from data published by courtesy of the General Electric Company showing in diagram (a) how output and harmonic distortion depend on load resistance in a triode. Similar curves relating to a pentode are given in diagram (b). Note that harmonic distortion increases each side of optimum resistance.

valve ratings are worked out or measured under conditions that do not strictly represent real life. There is a certain "optimum load resistance" into which a valve delivers the largest power with the least distortion. Naturally one aims at making the loud speaker resistance—looked at from the valve side of the output transformer—agree with this. (The resistance in question is, of course, that measured with alternating current at the frequency

pure resistance. If then the *lowest* impedance of the speaker is made equal to optimum, any increase at other working frequencies is all to the good so far as harmonic distortion is concerned. The reduction in output is less welcome; apart from the loss of volume as such, it occurs unequally over the frequency scale; in other words, *frequency distortion* is introduced. Actually it is not so serious as might be imagined; a decrease in the

Pentodes and Loud Speakers—

electrical power put into the speaker at the top end of the scale is usually compensated to a large extent by the characteristics of the speaker itself.

The pentode is not so. Either side of optimum load resistance there is a comparatively rapid increase in harmonic distortion for a given power (Fig. 1b). Therefore unless the speaker has been well matched to the valve in the first place, results are not at all up to expectations. Even when everything has been as well designed and carried out as possible, the inevitable variations of load resistance, and still more those of impedance, are likely to introduce appreciable distortion. Moreover, by looking at Fig. 1b you can see that when the load resistance increases the output rises. So that even if the percentage of harmonics remained steady, instead of rising steeply as it actually does, the amount of harmonics present would tend to increase. This is subject to a further complication due to the fact that the high impedance is inductive. As a matter of fact, the whole business is a great deal more complicated than I have revealed,

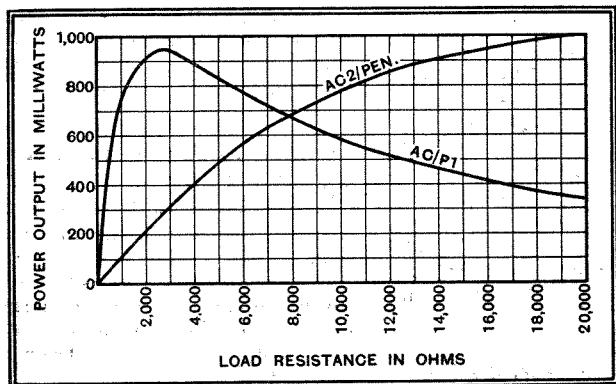

Fig. 2.—Comparative output curves of typical triode and pentode.

too much so to be discussed fully here. What I have given is the outline of the matter.

This rising output has still another unfavourable aspect. Harmonic distortion, by its very nature, causes shrillness. Most loud speakers, unless corrected by the conditions of use, tend as a result of upper frequency resonance to give shrill reproduction. At the same end of the scale the impedance rises; so the triode, as we have seen, helps to counteract such a tendency. But the pentode aggravates it. There is also a change of speaker impedance in the bass, which tends to cause similar unhappy results at that end of the scale.

Incidentally, with smaller valves of the types used in most receivers, working under typical conditions, the rise in pentode output is more marked than Fig. 1b suggests; see Fig. 2, taken from AC/PT and AC/2Pen valves.

The foregoing indictment of the pentode may sound rather depressing, but of course it should be realised that the calamities named become really bad only when the valve is driven up to or beyond its limits of power.

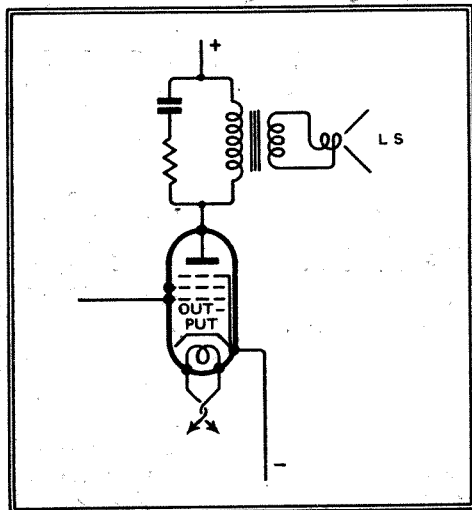

Fig. 3.—Tone correction circuit for minimizing load impedance variations.

The impedance of a good moving coil loud speaker does not vary to an enormous extent; but in the early days of pentodes the type in general use was the moving iron speaker, whose impedance is largely inductive. The result when driven by a pentode without suitable precautions was a piercing treble and no bass.

The "suitable precautions" just mentioned may now be considered. It is common practice to improve the rather doubtful quality of the pentode's output by shunting across the primary of the loud speaker transformer a condenser and resistance (Fig. 3). This is the familiar "tone correction circuit." So far as I have been able to find out, the choice of quantities here is never explained. So although it is a trifle more of an engineering matter than I usually discuss in these pages, there may be some excuse for its inclusion. To give readers who are not interested in design an excellent chance to miss it altogether, I shall make it into a separate article to appear later.

The Radio Industry

A NEW catalogue issued by F. W. Lechner & Co., Ltd., 61, Spencer Street, Clerkenwell, London, E.C.1, describes Kabi potentiometers, rheostats and switches (QMB and rotary).

We have received from the Radio Development Co., Aldwych House, Aldwych, London, W.C.2, a catalogue containing details of Epoch loud speakers, microphones, short wave and service components, valves, etc.

New PA speakers of the high impedance line type have been introduced by the G.E.C.; the units have a 5,000-ohm transformer primary and a 5-ohm speech coil to which direct connection can easily be made if required. Recent G.E.C. public-address installations include one at the Latchmere Road Baths,

Battersea and another on board H.M.S. *Royal Oak* has been commissioned. An output of 100 watts will feed 27 loud speaker points throughout the ship from an all-wave radio input, a microphone, or a gramophone pick-up.

Marconi-Ekco Instruments, Ltd., Electra House, Victoria Embankment, London, W.C.2, announces the introduction of three new instruments—an output power meter, a beat frequency microvolter, and a ganged condenser test bridge, the last-mentioned being produced in three different forms. Leaflets describing the instruments are available.

A notably attractive and well-prepared brochure entitled "That Which is Built Soundly . . ." has been sent to us by J. A. Crabtree and Co., Ltd., Lincoln Works, Walsall, the well-known manufacturers of electric accessories, fittings and switchgear.

Television Programmes

The principal items only of each day's programmes are given. The system to be used each day is given below the date. Transmission times are from 3-4 and 9-10 daily.

Vision	Sound
6.67 m. (45 Mc/s).	7.23 m. (41.5 Mc/s).

FRIDAY, DECEMBER 18th.
(Baird.)

3, David Seth-Smith with some animals and their keepers from the London Zoo. 3.15, British Movietone News. 3.25, Eric Wild and his Tea-Timers. 3.40, Film. 3.50, Music Makers—Yvonne Arnaud at the piano.

9, Roy and Alf—animal mimics. 9.10, Repetition of 3 programme. 9.25, Repetition of 3.25 programme. 9.40, British Movietone News. 9.50, Starlight—Frances Day.

SATURDAY, DECEMBER 19th.
(Baird.)

3, British Movietone News. 3.15, Variety with cartoons by Ernest Mills. 3.50, Film.

9, British Movietone News. 9.15, Variety. 9.50, Film.

MONDAY, DECEMBER 21st.
(Marconi-E.M.I.)

3, Display of new toys inspected by Harry Hemsley and his "children." 3.20, British Movietone News. 3.30, Joan Luxton's Children's Theatre Company.

9, Repetition of 3 programme. 9.20, British Movietone News. 9.30, Robert Spaight as Becket in scenes from "Murder in the Cathedral."

TUESDAY, DECEMBER 22nd.
(Marconi-E.M.I.)

3, Van Dock—quick-fire cartoonist and Vivienne Brooks in songs at the piano. 3.10, British Movietone News. 3.20, Royal Institution Lecture—G. I. Taylor explains with experiments why ships roll in a rough sea. 3.35, Film: "Beachmaster." 3.45, "Animals All!"

9, Nancy Logan in songs at the piano. 9.10, Film: "Morocco." 9.20, "Animals All!" 9.35, British Movietone News. 9.45, Starlight—Bebe Daniels and Ben Lyon.

WEDNESDAY, DECEMBER 23rd.
(Marconi-E.M.I.)

3, Guila Bustabo (violin) and the Television Orchestra. 3.15, British Movietone News. 3.25, Variety, including Ivor Moreton and Dave Kay, the original "Tiger Rag" pianists.

9, Repetition of complete afternoon programme.

THURSDAY, DECEMBER 24th.
(Marconi-E.M.I.)

3, Bransby Williams as "Scrooge." 3.15, British Movietone News. 3.25, Christmas Party—Old-time Music Hall.

9, Repetition of complete afternoon programme.

Current Topics

Christmas Greetings by Wireless

SPECIAL reduced rates are available for those who wish to send Christmas or New Year greetings by wireless to their friends overseas. Ten-word messages can be sent to Australia and New Zealand for 4s., and to Eastern Canada, New York, India, and South Africa for 2s. 6d. Such telegrams can be sent from any post office until January 6th, 1937.

New N.Z. High-power Station

THE new 60-kilowatt station which is being erected at Wellington, New Zealand, will be one of the most powerful in the Southern Hemisphere. The transmitting mast will be 700ft. high. The station will, it is hoped, begin testing very shortly.

New DF Station

THE number of air services over the Irish Sea has increased to such an extent that a wireless direction-finding station has become an absolute necessity, and one is to be established at Ronaldsway Airport, near Castletown, in the Isle of Man. The Air Ministry will bear the greater part of the cost of erecting it and half the maintenance costs.

PUBLISHER'S NOTICE

Next week's issue, dated December 25th, will be on sale on Thursday December 24th.

"The Girl Pat"

THE captain and crew who left England recently to man "The Girl Pat" took with them a special wireless telephone installation for use during the vessel's proposed world cruise.

Trouble in Sweden

THIS is not the only country where people are troubled by unscrupulous wireless listeners who allow their loud speakers to work with unnecessarily great volume. In Sweden there are ample means in the shape of police regulations to prevent people making a nuisance of themselves at night, but, according to the Swedish Minister of Justice, there is no law against excessive wireless and gramophone volume during the day, and the Government is contemplating the remedying of this unsatisfactory state.



Photos:
Bertram Par's

THEIR MAJESTIES KING GEORGE VI AND QUEEN ELIZABETH. The special interest which the King has always shown in wireless is particularly emphasised in the original design of an early broadcast receiver illustrated on this page.

"Tempering the Wind"

IN Norway listeners who live at considerable distances from a broadcasting station or in notoriously blind spots where reception is difficult only pay a quarter of the ordinary licence fee. There are 12,500 of these among a total of 225,000 listeners.

Great Britain Takes Second Place

THE total number of listeners in Germany on December 1st was 7,937,907, and it is confidently expected that the eight million mark will be passed by the New Year. The increase during the month of November was no less than 180,642. The latest figures available in the case of this country are those for November 1st when the total was 7,846,873. As the increase of the preceding month was only 59,593 it is exceedingly likely that we now no longer hold first place in Europe in the matter of listeners.

Radio Research Board for India?

PROFESSOR S. K. MITRA, of Calcutta, lecturing recently before Allahabad University students on the Ionosphere, explained that the existence of ionised regions at much lower altitudes than had hitherto been suspected had now been confirmed by British and American scientists. These layers, he explained, were first discovered by investigators at Calcutta. The professor dwelt on the extreme importance of establishing a radio research board in India;

the formation of a radio research station in the All-India Radio department did not, in his opinion, do away with the necessity for establishing a radio research board, as the work done by an organisation of the latter type would supplement rather than overlap the investigations carried out in the research laboratories of All-India radio.

France to Nationalise Radio?

IT is reported from Paris that the French Government has under consideration the question of nationalising the whole of the radio manufacturing industry. This idea is said to be in pursuance of the Government's plans to nationalise all industries having any connection with war activities. Radio will obviously be a most important factor in modern warfare.

Titles for Amateur Transmitters

THE titles of "Sniper of the Ether" and "Master of Short-Wave Connections" are to be conferred by the Government of the U.S.S.R. on certain amateur transmitters. The first-named title will be awarded to transmitters who establish two-way communication with all continents and with all regions of the U.S.S.R. The latter title will be conferred on those who, in addition to the qualifications already mentioned, have worked for not less than five years in the field of long-distance communication.

NEWS OF THE WEEK IN BRIEF REVIEW

Physical Society's Exhibition

THE twenty-seventh annual exhibition of scientific instruments and apparatus arranged by the Physical Society will be held at the Imperial College of Science and Technology, Imperial Institute Road, South Kensington, S.W.7, on January 5th, 6th and 7th, 1937.

N.R.E.A. Meeting

ON Thursday, December 3rd, the first annual general meeting of the National Radio Engineers' Association was held in London. After the usual routine business connected with the presentation of the balance sheet and the election of the Council for the coming year, plans were discussed for active organisation of forthcoming meetings and lectures. The hope was expressed that membership would increase to the same extent as in the year just completed. Full particulars of the Association may be obtained from the Hon. Secretary at 34, Bush Elm Road, Romford, Essex.

Small Ads. at Christmas

WITH the approach of the Christmas holidays slight alterations are necessary in our printing arrangements. Miscellaneous advertisements intended for the issue of December 25th must be received not later than first post on Saturday, December 19th.

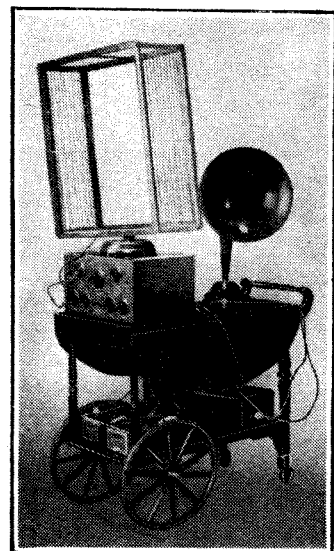

ROYAL RADIO.—H. M. the King's enthusiasm for wireless as long ago as 1923 is evident from this photograph, which was first published in *The Wireless World*, of the receiving equipment installed at White Lodge, Richmond Park, at that time. His Majesty's originality in the choice of design makes this transportable set of special interest.

Haynes Radio Television Equipment

PRACTICAL DETAILS AND COMPONENT VALUES

By F. H. HAYNES

IT is the purpose of these notes to fill the gap now so obviously existing between the many explanations which have appeared dealing with the working of the various television systems and the practical detailed instructions for the setting up of picture-receiving apparatus. Little has appeared concerning the circuits used in the manufacture of commercial television gear, and only sparse information has so far been available of

a kind likely to help the experimenter in pursuing what is undoubtedly one of the most attractive developments of radio.

The accompanying circuits are designed around those valves which are readily obtainable. Economy has been exercised in the number of components and types selected, while variables have been included so as to admit of every possible adjustment without need for modification of values.

Cathode Ray Tube High Tension Supply

A CONVENIENT housing for the tube may readily be constructed, using $\frac{1}{2}$ in. plywood, and provided with a removable side or panel to facilitate the handling of the tube and giving access to the various resistances and condensers which may be assembled inside and around the base cap. All condensers and resistances shown, with the exception of R93, R94, C88, and C89, are assembled inside the tube housing, and the spindles of the resistances R87, R89, and R92 protrude through and are fitted with $\frac{1}{4}$ in. extension handles made from $\frac{1}{2}$ in. ebonite rod with $\frac{1}{4}$ in. hole. The heater transformer T5 (b) is placed outside the container and immediately behind the tube socket in a position where its field will not influence the working of the tube. The HT transformer T5 (a) with its valve and pair of condensers and resistances forms a separate unit. The meter M2

may either be interposed in the outgoing negative lead or, if it is required to be at earth potential, in the position shown, but it should be kept away from the narrow part of the tube.

All wires of opposite polarity must be at least $\frac{1}{2}$ in. apart, and it should be remembered that the covering of leads with sleeving provides little protection against the sparking across of the high voltages. It should be noted that the secondary of the heater transformer is at high potential above earth, as are also the three controls as well as the leads passing to the receiver unit. It is essential, of course, that the heater current be applied before the HT supply. The grid of the CR tube should also be fully biased by sliding the contact on R92 to the right (in reference to the diagram) so that a stationary bright spot on the screen is avoided.

THE LIST OF PARTS WITH CIRCUIT REFERENCES

R84	50,000 ohms, $\frac{1}{2}$ watt, Dubilier metallised resistance.
R85	25,000 ohms, $\frac{1}{2}$ watt, Dubilier metallised resistance.
R86	3.5 megohms (7/0.5 megohm 1 watt Dubilier metallised resistances).
R87	0.5 megohm, Dubilier potentiometer, Type B.
R88	1 megohm (2/0.5 megohm 1 watt Dubilier metallised resistances).
R89	0.5 megohm, Dubilier potentiometer, Type B.
R90	100,000 ohms, 1 watt Dubilier metallised resistance.
R91	50,000 ohms, $\frac{1}{2}$ watt Dubilier metallised resistance.
R92	150,000 ohms, Dubilier potentiometer, Type B.
R93	250,000 ohms, 1 watt Dubilier metallised resistance.
R94	50,000 ohms, 1 watt Dubilier metallised resistance.
C84	0.1 mfd., 5,000 volt Dubilier oil immersed condenser, Type 951.
C85	1 mfd., 1,000 volt Dubilier oil immersed condenser, Type 950.
C86	2 mfd., 500 volt Dubilier paper dielectric condenser, Type LSA.
C87	2 mfd., 500 volt Dubilier paper dielectric condenser, Type LSA.
C88	0.1 mfd., 5,000 volt Dubilier oil immersed condenser, Type 950.
C89	0.1 mfd., 5,000 volt Dubilier oil immersed condenser, Type 950.
M2	0-2.5 mA., moving coil milliammeter.
V21	Rectifying valve, Osram Type Ur6.

T5	(a) HT transformer, 2 volts	} Haynes Type T90 TH
	4,500 volts	
T5	(b) Heater transformer, 1 volt + 1 volt, 2 amps, Haynes Type T20 H, or	} Haynes Type T40 H for optional 2-volt or 4-volt heater tubes.
	Heater transformer, 1 volt + 1 volt + 1 volt + 1 volt, 2 amps, Haynes Type T40 H for optional 2-volt or 4-volt heater tubes.	
Ediswan Type 12 H Cathode-Ray Tube:—		
	Heater volts	2.0
	Heater current	1.3 amps (approx.)
	3rd Anode voltage	6,000 max.
	2nd Anode voltage	1,200 approx.
	1st Anode voltage	400
	Max. input power to screen07 watt
	Grid bias	100/250 volts negative
	Sensitivity (mm. per volt)	950/V (where V is the potential of Anode 3)
	Peak-Peak Modulating voltage	20
	Modulation sensitivity in microamps. beam current per volt	1.5

Sound Receiver Unit

INCLUDED are circuit details of a superheterodyne attachment for use in front of a straight 2-RF tuner for sound reception.

Circuits of this class cause some small degree of interference to near-by sets by radiation from the aerial, and the intermediate frequency will need to be adjusted to permit of a setting of the tuning condensers C90 and C91 to a point where interference with the vision receiver, as evidenced by a "gauze" effect on the

image, is avoided. The normal IF position is at the lower end of the medium waveband, and the use of higher wavelength settings may render the tuning condenser C91 microphonic. It is better, of course, to use only a single superheterodyne for both sound and vision, selecting the two resultant intermediate frequencies by discriminating circuits connected in the anode of the triode-hexode frequency-changer.

THE LIST OF PARTS WITH CIRCUIT REFERENCES

C90	25 mmfds., max., pre-set air dielectric condenser, Cyldon.
C91	100 mmfds., + 100 mmfds., max. Cyldon Bebe type.
C92	25 mmfds., pre-set air dielectric condenser, Cyldon.
C93	25 mmfds., Dubilier ceramic dielectric condenser, Type CD.
C94	0.001 mfd., Dubilier mica dielectric condenser, Type 691.
C95	0.001 mfd., Dubilier mica dielectric condenser, Type 691.
C96	1 mfd. (part of triple 1 mfd., condenser block), Type BE/379 Dubilier paper dielectric condenser, 250 volts working.
C97	0.01 mfd., Dubilier mica dielectric condenser, Type 691.
C98	50 mmfds., Dubilier ceramic dielectric condenser, Type CD.
C99	0.001 mfd., Dubilier mica dielectric condenser, Type 691.
C100	2 mfd. (part of triple 1 mfd., condenser block), Type BE/379 Dubilier paper dielectric condenser, 250 volts working.
C191	3 mfd., Dubilier triple 1 mfd., condenser block, Type BE/379.

R95	35,000 ohms, Dubilier $\frac{1}{2}$ watt metallised resistance.
R96	10,000 ohms, Dubilier $\frac{1}{2}$ watt metallised resistance.
R97	25,000 ohms, Dubilier $\frac{1}{2}$ watt metallised resistance.
R98	25,000 ohms, Dubilier $\frac{1}{2}$ watt metallised resistance.
R99	50,000 ohms, Dubilier $\frac{1}{2}$ watt metallised resistance.
R100	500 ohms, Dubilier $\frac{1}{2}$ watt metallised resistance.
R101	25,000 ohms, Dubilier $\frac{1}{2}$ watt metallised resistance.

Lead K 210 volts-230 volts.

L15 5 turns No. 16 $\frac{3}{8}$ in. diameter, $\frac{3}{8}$ in. length, tapped 1st turn.

L16 5 turns No. 16 $\frac{3}{8}$ in. diameter, $\frac{3}{8}$ in. length, centre tapped.

L17 Short wave RF choke or 150 turns No. 40 swg., on $2\frac{1}{2}$ in. of $\frac{1}{2}$ in. dowel wood.

V20 Triode-hexode valve, Osram Type X4r.

SOUND RECEIVER UNIT

A single-valve ultra-short-wave converter can be used in conjunction with a broadcast receiver

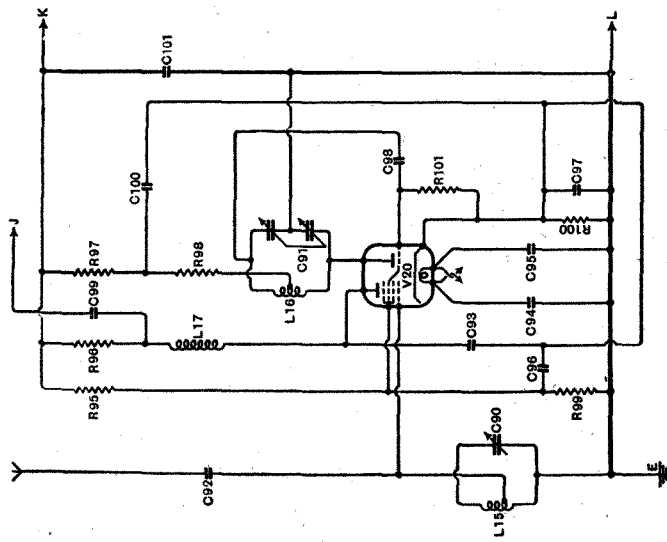

CATHODE RAY TUBE HT SUPPLY

In view of the high voltage employed, adequate insulation must be provided in all these circuits.

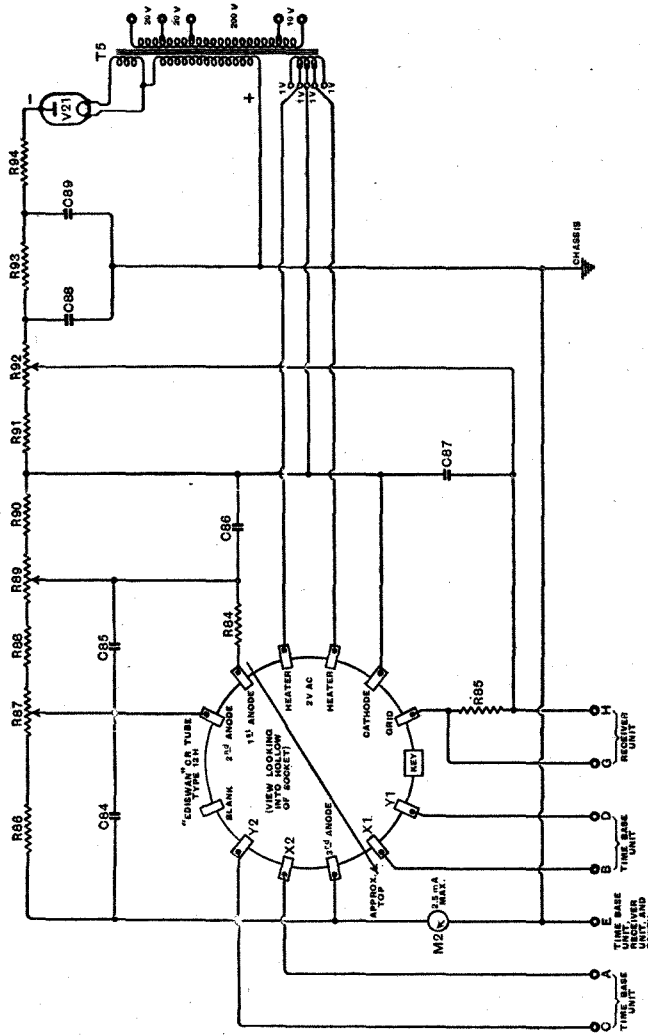

In this diagram are given the circuits of an ultra-short-wave converter for sound reception and of the high-voltage supply unit for the CR tube as well as the connections to the tube itself.

The Time Base

WHILE time base circuits of the hard valve type,* making use of normal receiving valves, are favoured by the writer, the amount of equipment involved leads to increased complication and cost. Soft grid-control relays V1, V2, are used in the circuit shown, and in most commercial television receivers with satisfactory results. The components may be assembled on a baseboard measuring some 2ft. square, the layout to follow the circuit diagram as closely as possible as to the disposition of the components. With the values given, sweep potentials will be developed sufficient to produce an image completely covering the screen of the CR tube. Adjustments of output amplitude if required may be obtained in respect of the vertical sweep (frames) by changes in C21 and C22 in relation to the setting of R33. For 50 frames† C21 and C23 may be series

* Circuit devised by A. C. Cossor, Ltd., and O. S. Puckle and shown in *Wireless World*, April 6th, 1934, page 238.

† The symbol following the frame and line numbers shown in the diagram is used to denote scanning frequency.

connected and a single condenser used for 25 frames. To assist in arriving at the correct values for 50 frames, the linear rectifying circuit of the valve V7 has been added, and, subject to the mains being connected in the correct direction, this arrangement will hold the frame synchronising.

Care must be taken to arrange that all coupling condensers in the line time base are of low capacity to earth if assembly is carried out on a metal baseplate. Earth capacity on these condensers or on the line C and D will reduce the length of the line scan, and consequently the width of the picture. Provision is made for adjustment of picture width by the controls R34 and R36, which serve also to make the line sweep of constant velocity.

The mains side of the heater transformer T1 (b) should be coupled up with the small transformer of the CR tube, and the transformer T1 (a) coupled with the CR tube HT transformer. Current must be applied to all heaters for some time before switching on the HT supplies.

THE LIST OF PARTS WITH CIRCUIT REFERENCES

- | | | | |
|------------|--|------------|--|
| R1 | 250,000 ohms, Dubilier $\frac{1}{2}$ watt metallised resistance. | C7 | 2 mfd., Dubilier paper dielectric condenser, 250 volts working. |
| R2 | 2/10,000 ohms, Dubilier 1 watt metallised resistances in series. | C8 | 2 mfd., Dubilier paper dielectric condenser, 250 volts working. |
| R3 | 10,000 ohms, Dubilier $\frac{1}{2}$ watt metallised resistance. | C9 | } 2 + 2 mfd., Dubilier oil immersed condenser, 1,500 volts working.
Type 95I. |
| R4 | 5,000 ohms, Dubilier $\frac{1}{2}$ watt metallised resistance | C10 | |
| R5 | 1,000 ohms, Dubilier $\frac{1}{2}$ watt metallised resistance. | C11 | 0.1 mfd., oil immersed condenser, 1,500 volts working, Type 95I. |
| R6 | 15,000 ohms, Dubilier $\frac{1}{2}$ watt metallised resistance. | C12 | 2/0.005 mfd., Dubilier mica dielectric condensers in series. |
| R7 | 5,000 ohms, Dubilier $\frac{1}{2}$ watt metallised resistance. | C13 | 0.1 mfd., Dubilier oil immersed condenser, 1,500 volts working.
Type 95I. |
| R8 | 1.5 megohms, Dubilier 2 watt metallised resistance, optionally in series with 0.5 megohm Dubilier variable resistance (potentiometer, Type B). | C14 | 2/0.005 mfd., Dubilier mica dielectric condensers in series. |
| R9 | 1.5 megohms, Dubilier metallised resistance, 2 watts. | C15 | 0.1 mfd., Dubilier oil immersed condenser, 1,500 volts working, Type 95I. |
| R10 | 1,000 ohms, Dubilier 1 watt metallised resistance. | C16 | 2/0.005, mfd. Dubilier mica dielectric condensers in series. |
| R11 | 250 ohms, Dubilier 1 watt metallised resistance. | C17 | 0.1 mfd., Dubilier oil immersed condenser, 1,500 volts working, Type 95I. |
| R12 | 1 megohm, Dubilier $\frac{1}{2}$ watt metallised resistance. | C18 | 2/0.005 mfd., mica dielectric condensers in series. |
| R13 | 2/50,000, Dubilier 1 watt metallised resistances in series. | C19 | 1 mfd., Dubilier paper dielectric condenser, 250 volts working. |
| R14 | 1 megohm, Dubilier $\frac{1}{2}$ watt metallised resistance. | C20 | 1 mfd., Dubilier paper dielectric condenser, 250 volts working. |
| R15 | 5 megohms, Dubilier $\frac{1}{2}$ watt metallised resistance. | C21 | 0.1 mfd., Dubilier oil immersed condenser, 1,500 volts working, Type 95I. |
| R16 | 5/100,000 ohms, Dubilier 1 watt metallised resistances in series. | C22 | Approximately 0.0002 mfd. (composed of 4/0.001 Dubilier Type 69I in series with 0.001 mfd. variable. A close value can be found by experiment, thus avoiding the use of the large variable). |
| R17 | 5/100,000 ohms, Dubilier 1 watt metallised resistances in series. | C23 | 0.1 mfd., Dubilier oil immersed condenser, 1,500 volts working, Type 95I. |
| R18 | 2/100,000 ohms, Dubilier 1 watt metallised resistances in series. | C24 | Approximately 0.0005 mfd. (composed of Dubilier 0.001 mfd., Type 69I, in series with 0.001 mfd., variable. A close value can be found in order to avoid the use of the variable). |
| R19 | 100,000 ohms, Dubilier 1 watt metallised resistance. | C26 | 1 mfd., Dubilier paper dielectric condenser, 250 volts working. |
| R20 | 10,000 ohms, Dubilier $\frac{1}{2}$ watt metallised resistance. | C28 | 1 mfd., Dubilier paper dielectric condenser, 250 volts working. |
| R21 | 10,000 ohms, Dubilier $\frac{1}{2}$ watt metallised resistance. | T1 | Consists of a pair of transformers: |
| R22 | 4/100,000 ohms, Dubilier 1 watt metallised resistances in series. | | (a) Eliminator transformer, Haynes Type T90 TBH.
1,500 volts 30 mA. 250-0-250 volts 30 mA. 4 volts 1 amp.
4 volts 1 amp. |
| R23 | 5/100,000 ohms, Dubilier 1 watt metallised resistances in series. | | (b) Heater transformer, Haynes Type T50 H.
4 volts 1 amp. 4 volts 7 amp CT. |
| R24 | 5 megohms, Dubilier $\frac{1}{2}$ watt metallised resistance. | L1 | 100 henries 30 mA, 900 ohms, Haynes Type L10. |
| R25 | 3 megohms, Dubilier $\frac{1}{2}$ watt metallised resistance. | L2 | 50 henries 60 mA, 600 ohms, Haynes Type L5. |
| R26 | 5 megohms, Dubilier $\frac{1}{2}$ watt metallised resistance. | L3 | 500 μ H. choke, Haynes Type LD2. |
| R27 | 3 megohms, Dubilier $\frac{1}{2}$ watt metallised resistance. | V1 | Grid-controlled rectifier valve, Osram Type GT1B. |
| R28 | 50,000 ohms, Dubilier $\frac{1}{2}$ watt metallised resistance. | V2 | Grid-controlled rectifier valve, Osram Type GT1B. |
| R29 | 50,000 ohms, Dubilier $\frac{1}{2}$ watt metallised resistance. | V3 | Power triode Mazda Type ACP1. |
| R30 | 50,000 ohms, Haynes volume control. | V4 | Triode, Osram Type MH4. |
| R31 | 50,000 ohms, Haynes volume control. | V5 | Power triode, Mazda Type ACP1. |
| R32 | 2,500 ohms, Haynes volume control. | V6 | Triode, Osram Type MH4. |
| R33 | 2,500 ohms, Haynes volume control. | V7 | Triode, Osram Type MH4. |
| R34 | 15,000 ohms, Haynes volume control. | V8 | Rectifying valve, Osram Type U17. |
| R35 | 5 megohms, Dubilier $\frac{1}{2}$ watt metallised resistance. | V9 | Rectifying valve, Osram Type U10. |
| R36 | 15,000 ohms, Haynes volume control. | | |
| R38 | 25,000 ohms, Dubilier $\frac{1}{2}$ watt metallised resistance. | | |
| R40 | 25,000 ohms, Dubilier $\frac{1}{2}$ watt metallised resistance. | | |
| C1 | } 2 mfd., + 2 mfd., Dubilier oil immersed condenser, earthed case,
working voltage 1,500, Type 95I. | | |
| C2 | | | |
| C3 | } 16 mfd., Dubilier triple 8 mfd., electrolytic condenser, case
insulated from earth, Type 920E. | | |
| C4 | | | |
| C5 | 0.1 mfd., Dubilier oil immersed condenser, 1,500 volts working, Type 95I. | | |
| C6 | 0.0005 mfd., mica dielectric condenser, Dubilier, Type 69I. | | |

Care must, of course, be exercised when handling both the time base and CR tube HT supplies. They should have their mains transformers wired together to a separate switch, and it is worth while devising some indicating arrangement to warn one of the danger that the HT circuits are in operation. To prevent the HT supplies being on without the heaters of the valves, the mains supply to the HT transformers should be drawn from the primary of one of the heater transformers, via the switch. Insulating extension handles should be slipped on to all controls associated with the HT circuits. Equally, care should be exercised to check over for the absolute correctness of all CR tube connections before applying voltages. A zin. extension around the front of the box work housing for the CR tube should be provided permitting of the fixing of a $\frac{1}{4}$ in. plate-glass cover to obviate the dangers of implosion.

THE TIME BASE A phase-reversing valve is used in each of the two time-bases in order to reduce the HT voltage and to avoid trapezium distortion.

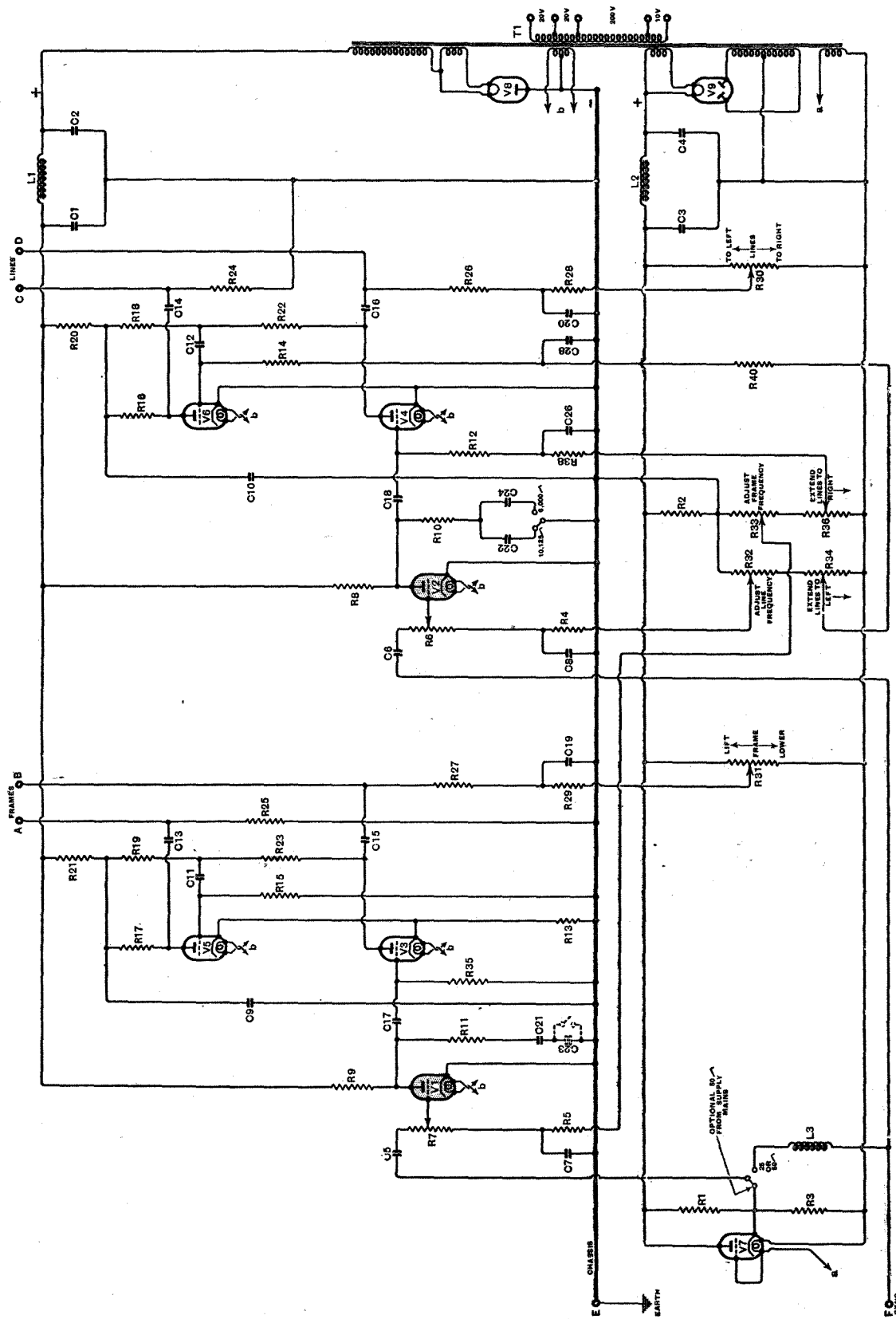

The saw-tooth waveforms are generated by means of gas-filled relays and are amplified to the requisite degree by pairs of triodes operating in opposite phase.

Vision Receiver

WHILE tuned transformer IF couplings may be favoured, it is explained that the single side-band choke-coupled arrangement adopted is much easier to construct, and avoids the extreme complication which results when attempting to adjust a large number of tuned circuits which may border on a regenerating condition. The choke-coupled system* provides a stable amplifier while solving the problem of embracing a wide side band of 5 Mc/s. The volume control R49 associated with the second IF valve V12 provides a safeguard against regeneration by decreasing the gain between successive stages.

It should be noted that the amplitude filter valve V16 receives only part of the available voltage output from the IF amplifier,

and is arranged to give uniform synchronising impulses to the time base with almost complete independence of the picture modulation.

As stated earlier, the two aerial frequencies representing sound and vision give rise to two intermediate frequencies with a given setting of the oscillator condenser C31. It is not necessary, therefore, to duplicate the triode-hexode and its associated circuits for sound and vision reception, but to interpose a tuned IF circuit commencing from the point marked X adjoining L9. If this is done, the condenser C30 may be omitted as well as the dipole for distances from the transmitter not exceeding some seven miles. Reference is made in the list of parts to the need for special insulation and low capacity between the windings of transformers T3 and T4.

* Shown by von Ardenne in his recent book "Television Reception." See also the *Wireless World*, April 26th and May 3rd, 1935, for design details of this type.

THE LIST OF PARTS WITH CIRCUIT REFERENCES

- | | | | |
|------------|---|------------|--|
| C30 | 25 mmfds., max. air dielectric condenser, pre-set, Cyldon. | R49 | 15,000 ohms, Haynes volume control. |
| C31 | 100 mfd., + 100 mfd., max. condenser, Cyldon Bebe type. | R50 | 1 megohm, Dubilier $\frac{1}{2}$ watt metallised resistance. |
| C32 | 25 mmfds., max. air dielectric condenser, pre-set, Cyldon. | R51 | 350 ohms, Dubilier $\frac{1}{2}$ watt metallised resistance. |
| C33 | 0.002 mfd., Dubilier mica dielectric condenser, Type 691. | R52 | 3,500 ohms, Dubilier $\frac{1}{2}$ watt metallised resistance. |
| C34 | 0.002 mfd., Dubilier mica dielectric condenser, Type 691. | R53 | 1 megohm, Dubilier $\frac{1}{2}$ watt metallised resistance. |
| C35 | 0.002 mfd., Dubilier mica dielectric condenser, Type 691. | R54 | 700 ohms, Dubilier $\frac{1}{2}$ watt metallised resistance. |
| C36 | 50 mmfds., Dubilier ceramic dielectric condenser. | R55 | 3,500 ohms, Dubilier $\frac{1}{2}$ watt metallised resistance. |
| C37 | 0.002 mfd., Dubilier condenser, Type 691. | R56 | 250,000 ohms, Dubilier $\frac{1}{2}$ watt metallised resistance. |
| C38 | 0.002 mfd., Dubilier condenser, Type 691. | R57 | 1,000 ohms, Dubilier $\frac{1}{2}$ watt metallised resistance. |
| C39 | 0.002 mfd., Dubilier condenser, Type 691. | R58 | 500 ohms, Dubilier $\frac{1}{2}$ watt metallised resistance. |
| C40 | 0.002 mfd., Dubilier condenser, Type 691. | R59 | 2,500 ohms, Dubilier $\frac{1}{2}$ watt metallised resistance. |
| C41 | 0.002 mfd., Dubilier condenser, Type 691. | R60 | 25,000 ohms, Dubilier $\frac{1}{2}$ watt metallised resistance. |
| C42 | 0.002 mfd., Dubilier condenser, Type 691. | R61 | 100 ohms, Dubilier $\frac{1}{2}$ watt metallised resistance. |
| C43 | 0.0001 mfd., Dubilier condenser, Type 690. | R62 | 5,000 ohms, Dubilier $\frac{1}{2}$ watt metallised resistance. |
| C44 | 0.002 mfd., Dubilier condenser, Type 691. | R63 | 25,000 ohms, Dubilier $\frac{1}{2}$ watt metallised resistance. |
| C45 | 0.002 mfd., Dubilier condenser, Type 691. | R64 | 500 ohms, Dubilier $\frac{1}{2}$ watt metallised resistance. |
| C46 | 0.002 mfd., Dubilier condenser, Type 691. | R65 | 25,000 ohms, Dubilier $\frac{1}{2}$ watt metallised resistance. |
| C47 | 0.0001 mfd., Dubilier condenser, Type 690. | R66 | 500 ohms, Dubilier $\frac{1}{2}$ watt metallised resistance. |
| C48 | 0.002 mfd., Dubilier condenser, Type 691. | R67 | 500 ohms, Dubilier $\frac{1}{2}$ watt metallised resistance. |
| C49 | 0.002 mfd., Dubilier condenser, Type 691. | R68 | 500 ohms, Dubilier $\frac{1}{2}$ watt metallised resistance. |
| C50 | 0.002 mfd., Dubilier condenser, Type 691. | R69 | 500 ohms, Dubilier $\frac{1}{2}$ watt metallised resistance. |
| C51 | 0.0001 mfd., Dubilier condenser, Type 690. | R70 | 500 ohms, Dubilier $\frac{1}{2}$ watt metallised resistance. |
| C52 | 0.002 mfd., Dubilier condenser, Type 691. | R71 | 500 ohms, Dubilier $\frac{1}{2}$ watt metallised resistance. |
| C53 | 0.002 mfd., Dubilier condenser, Type 691. | R72 | 500 ohms, Dubilier $\frac{1}{2}$ watt metallised resistance. |
| C54 | 0.002 mfd., Dubilier condenser, Type 691. | R73 | 500 ohms, Dubilier $\frac{1}{2}$ watt metallised resistance. |
| C55 | 0.002 mfd., Dubilier condenser, Type 691. | R74 | 500 ohms, Dubilier $\frac{1}{2}$ watt metallised resistance. |
| C56 | 0.002 mfd., Dubilier condenser, Type 691. | R75 | 1,000 ohms, Dubilier $\frac{1}{2}$ watt metallised resistance. |
| C57 | 0.0001 mfd., Dubilier condenser, Type 690. | R76 | 3,500 ohms, Dubilier $\frac{1}{2}$ watt metallised resistance. |
| C58 | 0.002 mfd., Dubilier condenser, Type 691. | R77 | 1,500 ohms, Dubilier $\frac{1}{2}$ watt metallised resistance. |
| C59 | 0.002 mfd., Dubilier condenser, Type 691. | R78 | 1,500 ohms, wire strip type. |
| C60 | 0.002 mfd., Dubilier condenser, Type 691. | R79 | 3,000 ohms (2/1,500 wire strips). |
| C61 | 0.002 mfd., Dubilier condenser, Type 691. | R80 | 3,000 ohms (2/1,500 wire strips). |
| C62 | 0.002 mfd., Dubilier condenser, Type 691. | R81 | 1,500 ohms, Haynes volume control. |
| C63 | 0.002 mfd., Dubilier condenser, Type 691. | R82 | |
| C64 | 0.0001 mfd., Dubilier condenser, Type 690. | L4 | 5 turns No. 16, $\frac{3}{8}$ in. diameter, $\frac{5}{8}$ in. length, centre tapped and also at two points half a turn off centre tap. |
| C65 | 0.002 mfd., Dubilier condenser, Type 691. | L5 | 5 turns No. 16, $\frac{3}{8}$ in. diameter, $\frac{3}{4}$ in. length, centre tapped |
| C66 | 0.002 mfd., Dubilier condenser, Type 691. | L6 | Two-start winding of No. 22 DCC. on bobbin $1\frac{1}{2}$ in. long \times 1in. dia. |
| C67 | 0.002 mfd., Dubilier condenser, Type 691. | L7 | |
| C68 | 0.002 mfd., Dubilier condenser, Type 691. | L8 | 20 turns No. 40 enam., winding space $\frac{3}{16}$ in. |
| C69 | 0.001 mfd., Dubilier condenser, Type 691. | L9 | 120 turns No. 40 enam., winding space $1\frac{1}{16}$ in. |
| C70 | 0.0001 mfd., Dubilier condenser, Type 690. | L10 | 150 turns No. 44 resistance wire. |
| C71 | 1 mfd., part triple 1 mfd., condenser block (with C74 and C75). | L11 | |
| C72 | 0.01 mfd., Dubilier condenser, Type 691. | L12 | |
| C73 | 0.01 mfd., Dubilier condenser, Type 691. | L13 | As L9. |
| C74 | 1 mfd., part triple 1 mfd., condenser block, Dubilier. | L14 | Smoothing choke Haynes Type L3. |
| C75 | 1 mfd., part triple 1 mfd., condenser block, Dubilier. | T2 | (a) HT transformer 250 volts + 250 volts, 120 mA. max., 4 volts 2.5 amps. Haynes Type 50 F. |
| C76 | 0.0001 mfd., Dubilier condenser, Type 690. | | (b) Heater transformer 4 volts, 10 amps, centre-tapped. Haynes Type 50 H. |
| C77 | 0.01 mfd., Dubilier condenser, Type 691. | T3 | 4 volts 1.5 amps., CT. Haynes Type LD5. } High insulation and low capacity between windings. |
| C78 | 0.01 mfd., Dubilier condenser, Type 691. | T4 | |
| C79 | 8mfds., part 8 + 8 mfd., Dubilier electrolytic condenser. | V10 | Triode-hexode frequency-changer, Osram Type X41. |
| C80 | 8 mfds., part 8 + 8 mfd., Dubilier electrolytic condenser. | V11 | |
| C81 | 8 mfds., part 8 + 8 mfd., Dubilier electrolytic condenser. | V12 | |
| C82 | 8 mfds., part 8 + 8 mfd., Dubilier electrolytic condenser. | V13 | |
| R41 | 500 ohms, Dubilier $\frac{1}{2}$ watt metallised resistance. | V14 | Variable-mu screened pentode, Osram Type VMP4G. |
| R42 | 25,000 ohms, Dubilier $\frac{1}{2}$ watt metallised resistance. | V15 | |
| R43 | 25,000 ohms, Dubilier $\frac{1}{2}$ watt metallised resistance. | V16 | Triode, Osram Type ML4. |
| R44 | 1 megohm, Dubilier $\frac{1}{2}$ watt metallised resistance. | V17 | |
| R45 | 350 ohms, Dubilier $\frac{1}{2}$ watt metallised resistance. | V18 | Screen-grid detector, synchronising circuit, Osram Type MS4B. |
| R46 | 3,500 ohms, Dubilier $\frac{1}{2}$ watt metallised resistance. | V19 | |
| R47 | 1 megohm, Dubilier $\frac{1}{2}$ watt metallised resistance. | | Single diodes, Osram Type D42. |
| R48 | 350 ohms, Dubilier $\frac{1}{2}$ watt metallised resistance. | | Rectifying valve, Osram Type U14. |

THE VISION RECEIVER

Single sideband reception is adopted together with a push-pull diode detector.

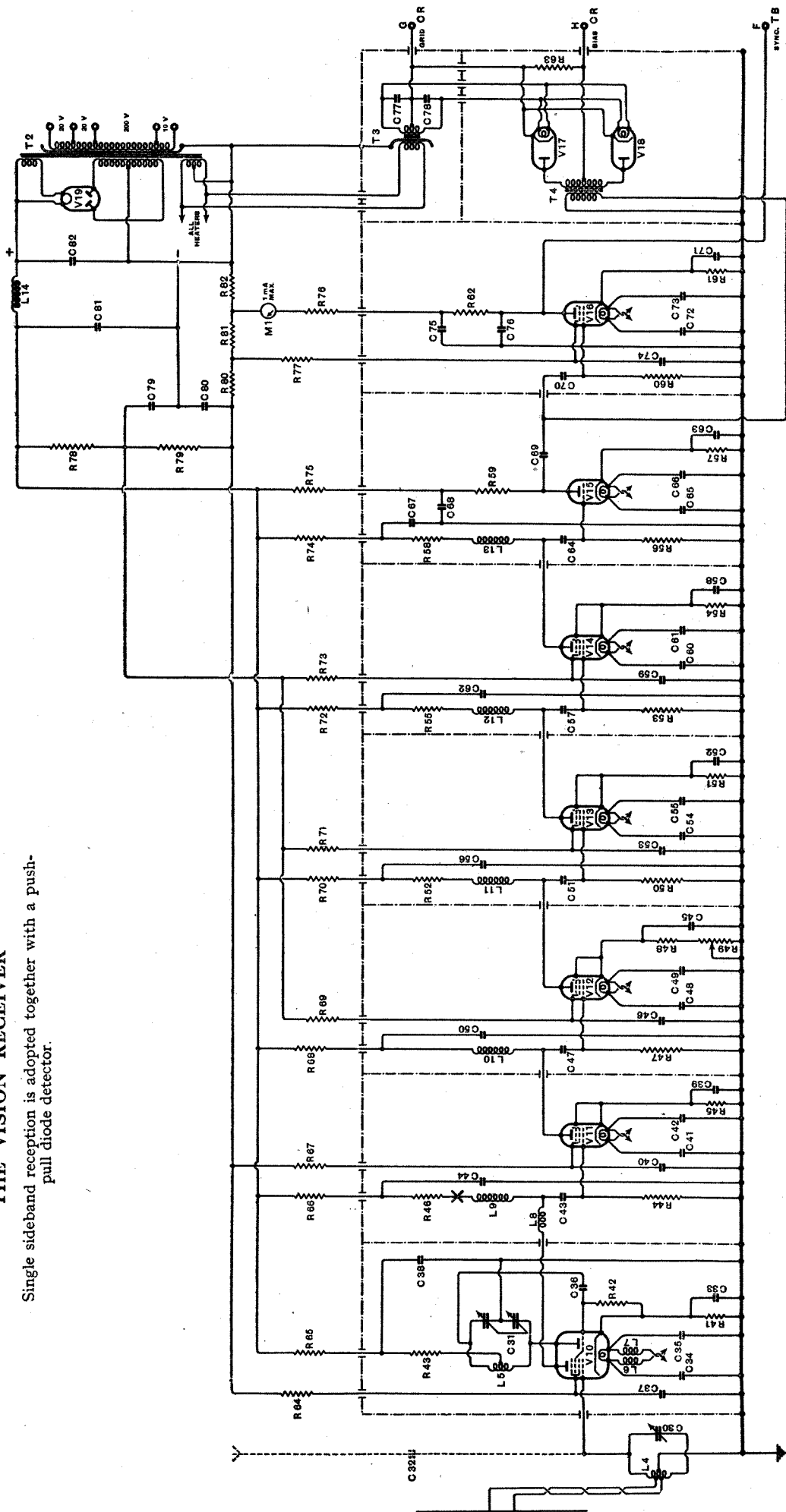

As the circuit diagram shows, the frequency-changer is followed by five IF stages and a push-pull detector. The valve V16 is an amplitude filter for separating the synchronising pulses.

UNBIASED

By FREE GRID

Sidelights on Soho

YOU frequently read a lot of rubbish in the daily papers to the effect that the number of broadcast listeners is reaching saturation point, but this is in all probability due to the crass ignorance of the average lay journalist when he steps into realms outside his somewhat limited intelligence, and there is, therefore, probably some excuse for it. The same excuse cannot, however, be put forward for the wireless manufacturer who is said to lie awake at night wondering how he is going to keep the wolf from the door of his humble cottage during the forthcoming years because he foolishly imagines that almost everybody who intends buying a set has already done so, and that there are no fresh markets to conquer.

In actual practice there are vast communities of people who are simply waiting for some enterprising person to produce sets suitable to their financial status and thereby reap a golden harvest. So far, the manufacturers have made not the faintest attempt to cater for this great class of people, with the result that they are sunk in abysmal ignorance concerning broadcasting, although I must confess that until recently even I had not appreciated that this ignorance was as great as I have since found it to be.

It so happened that on a recent evening when a running commentary on a pugilistic encounter was broadcast I and a friend were detained late at the office on special business, and so we did not emerge into the



Unceremoniously bundled out on to the pavement.

street until nearly 10 p.m., when the broadcast was in full swing. I was surprised to note that all the way down the street in which we found ourselves, there were little knots of people gathered at the partly opened doors of the numerous little cafés of rather doubtful type which infest this part of the Metropolis.

We naturally approached one of these groups and demanded what was in the wind, but were immediately hushed into silence by a few coarse epithets from the people around us. By using our own power of observation we eventually found that the people at the various café doors were eagerly listening to the account of the boxing match which was emanating from the receivers inside.

Naturally, in order to hear better, my friend and I immediately pushed our way into one of these establishments and made a request for coffee to the greasy-looking youth who shuffled up to take our order. Apparently this was the type of establishment where the C.O.D. rule was strictly enforced, and consequently the attendant youth held out his hand for payment immediately on delivering the evil-smelling beverage to us. To our embarrassment, we found that we were both penniless, having apparently left our money on the Crown and Anchor board with which we had been experimenting in *The Wireless World* laboratory. The offer of a cheque merely brought forth a volley of abuse, and we were unceremoniously bundled out on to the pavement, where we received further abuse from the people outside, owing to our interrupting their hearing of the broadcast.

Unbelievable Ignorance

It need scarcely be said that we lost no opportunity in trying to find out from our fellow auditors why it was that they were listening in this surreptitious manner in the street instead of by their own firesides as, of course, we could scarcely believe that such a vast concourse of people had, like ourselves, been detained at their offices on business. To our intense surprise we found that not a single one of them was a set owner, and, what was worse, some of them had not even the most elementary notion of the manner in which broadcasting was carried out.

This last piece of information we ascertained owing to the fact that outside one of the cafés a fierce argument was in progress as to whether it was then the eleventh or the twelfth round that was being dealt with by the commentator. It appeared that at the end of the tenth round the loud speaker had suddenly ceased working and, in spite of some frantic knob twiddling that was done by the proprietor of the café, several moments elapsed before the programme came on again. The greater part of the crowd were so ignorant that they appeared to be quite unaware of the fact that the fight was a real flesh and

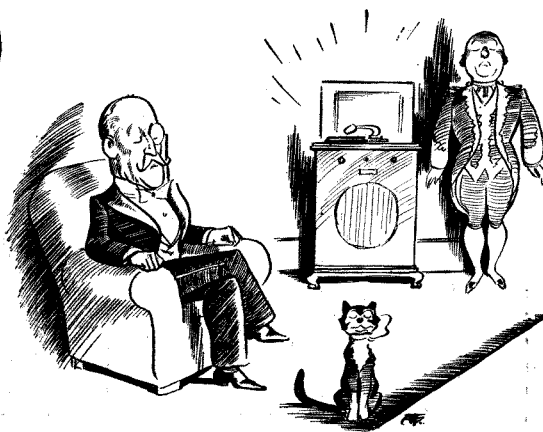

An attendant menial to change the records.

blood affair, but thought, apparently, that it was a piece of entertainment simply emanating from a sort of gramophone record inside the set, and that the temporary breakdown necessarily implied a corresponding hold-up in the "fight." Hence the difference of opinion concerning which round it was.

A Mad-Hatter Policy

THE ways of manufacturers, like the goings on of women, are strange and passing my comprehension. What moves me to make this remark at this particular juncture is the fact that I have just been reading all about the new sets with which a certain manufacturer is going to startle us next year.

This particular manufacturer has hitherto religiously eschewed the provision of a gramophone record-changer in any of his radio-gramophones for the somewhat naive reason that he thought people didn't really want them. However, he must have learned at last that such altruism as refraining from giving people what they didn't want simply won't work, for I notice that he is now going in for record-changers, short waves and such-like sinful vanities. What gets my goat, however, is the fact that the record-changer is to be chucked in in the very model where it will do least good, namely, the most expensive one. It is, of course, the very cheapest one which, by rights, ought to come first, as it stands to reason that purchasers of the least expensive sets are the very ones who want everything done automatically, as they can least afford to pay an attendant menial to change the record for them.

I am not blaming this manufacturer in particular; it is merely that his effort is the proverbial last straw. Other manufacturers are just as bad. In the case of the wares of some set makers, the purchasers of the very cheapest don't get any AVC, whereas the rich man who can afford to employ an expert operator to stand by the knob all the time and keeps things up to scratch gets it all done automatically for him. Still, this sort of injustice has always been the same in this life, and I suppose it always will. The man who can least afford to keep them usually has the most children.

Imperial Transportable MODEL P23

A NEAT BATTERY RECEIVER OF ORIGINAL DESIGN

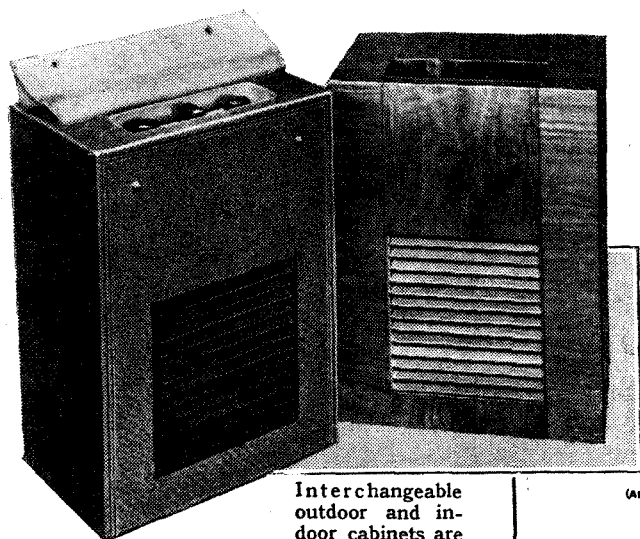

Interchangeable outdoor and indoor cabinets are available.

TO achieve the compactness required in a portable receiver most makers find it necessary to make the cabinet the foundation unit upon which the various components are assembled. There is no technical objection to this method of construction except perhaps from the point of view of possible future overhauls; but the alternative, though somewhat more expensive, plan of keeping the "works" entirely separate from the case has possibilities which seem to have been overlooked.

In the Imperial Transportable the carry-

ing case is really a cover which slides over the receiver unit and is held in position by two screws at the base. When the set is to be taken afield for picnics, etc., a robust leather-covered case may be used and in the intervening periods when the set is being employed as an ordinary

FEATURES. — **Type.** — Transportable receiver for battery operation. **Circuit.** — Pentode reflex RF and AF amplifier—pentode grid detector—pentode output valve. **Controls.** — (1) Tuning. (2) Volume (reaction). (3) Waverange and on-off switch. **Price.** — De Luxe model 8½ guineas. Interchangeable indoor cabinet 1 guinea extra. **Makers.** — Bellerset Radio Ltd., Clarendon Road, Montague Street, Worthing.

substitute for a screw-driver. The outdoor carrying case for the de luxe model is fitted with a waterproof flap which covers the controls, and the indoor model

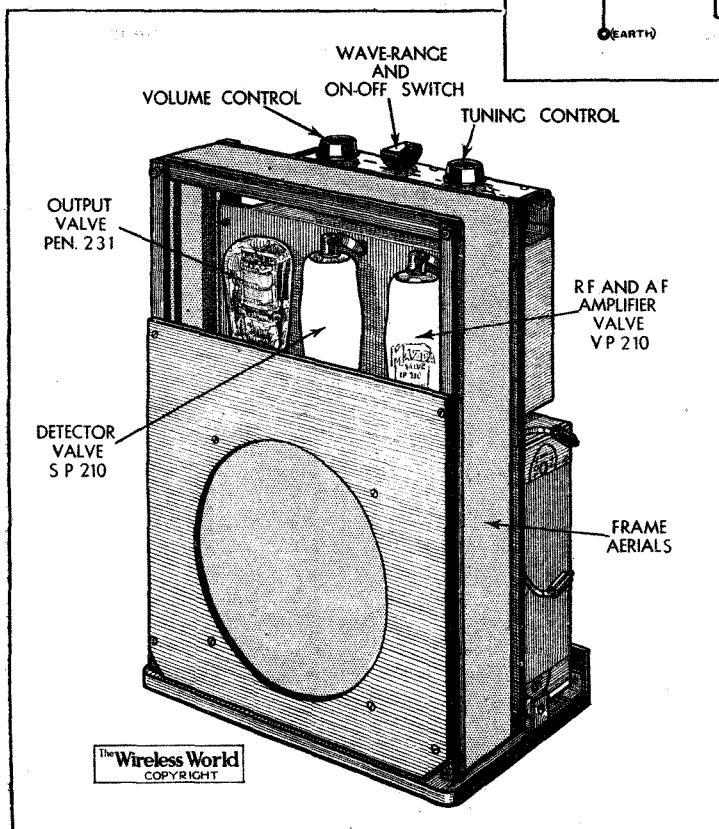
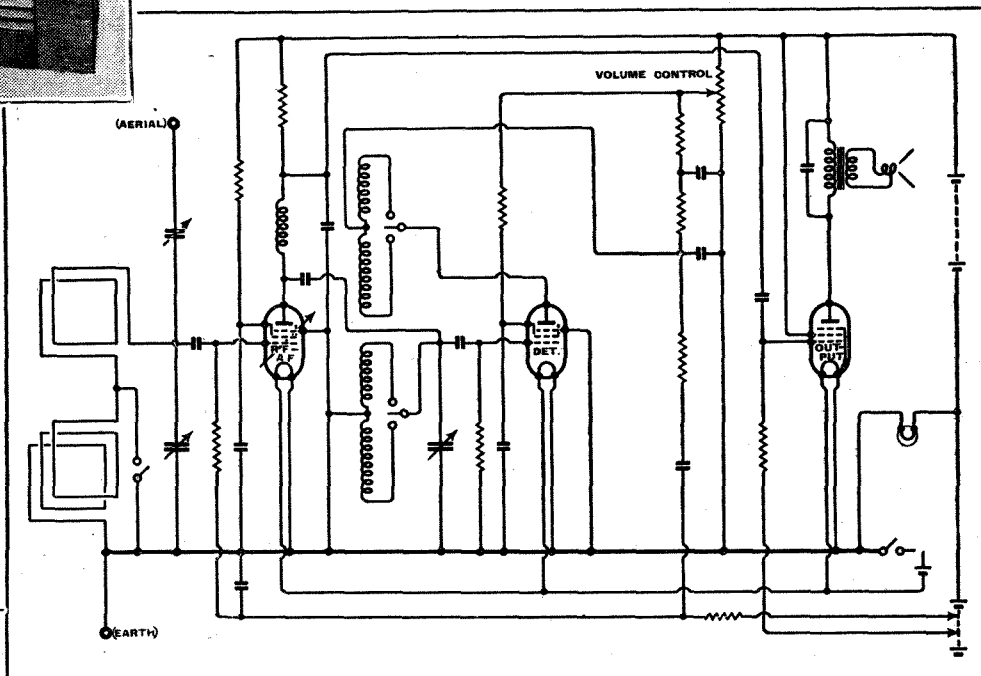

The Wireless World
COPYRIGHT

The reflex circuit, in which the first valve functions both as an RF and AF amplifier, provides a high degree of sensitivity.

domestic receiver a high-grade polished wood cabinet matching the furniture may be substituted. To exchange the cabinet is but the work of a moment, as the screws are provided with slots into which a coin may be inserted as a

The receiver unit, which is mounted on a turntable base, is entirely independent of the cabinet.

can, if desired, be provided with a small stool which converts the receiver into a console of armchair height. Loudspeaker louvres are fitted at both sides of the cabinet and the ebonised wooden slats are deflected downwards to afford protection from the weather.

It will be seen from the sketch that the receiver unit is unusually neatly arranged with valves and batteries immediately accessible. The main portion of the circuit is completely enclosed in a metal chassis with the controls projecting vertically upwards. There are three valves in the circuit, but these give in effect four stages as the first valve is reflexed and functions both as an RF and AF amplifier. All three valves are of the pentode type, the first two being metallised. The input from the tuned frame aerial passes through the first valve and is amplified at radio frequency before rectification by the second stage. The rectified signal is then passed back through a resistance-capacity filter to the grid of the first valve which then provides a first stage of audio-frequency amplification before the final output pentode

Imperial Transportable Model P23—

valve. Resistance-capacity coupling is employed throughout, and reaction is applied by fixed coils coupled to the tuned grid circuit between the first and second stages. The control of reaction is unusual and is effected by potentiometer control of the screen and anode voltages in the detector stage.

The loud speaker is a permanent magnet moving coil, and gives clear reproduction and ample volume before overload distortion sets in. The over-all sensitivity is such that it is possible to overload the output stage, but attention to the reaction control easily overcomes this difficulty. Reaction, incidentally, is by no means critical, and excellent range and volume are obtained with settings far below the threshold of oscillation. Having found the best average setting of the reaction control for the medium or long waveband no further attention is required, and the single knob tuning control may be turned from one station to another with perhaps an occasional movement of the set as a whole on its ball-bearing turntable to take

full advantage of the directional properties of the frame.

There can be little doubt that apart from the increased amplification resulting the reflexed circuit in this receiver is distinctly above the average in sensitivity. In Central London the North and West Regional stations provided an excellent programme at all times of the day, and Continental stations, such as Fécamp and Poste Parisien, are equally reliable. The long waves appeared to be equally good, and the selectivity is adequate for comfortable separation of Droitwich and Radio-Paris. The measured HT consumption in the set tested was 7.2 mA., and this figure remained practically constant for all settings of the controls. The LT current was 0.45 amp., which should give a service of no less than 40 hours on a single charge. The weight of the complete set is 17½ lb.

The sensitivity on weak stations and the neatness and originality of the general design are alone features which give this receiver an individuality which should appeal to those seeking for something a little out of the ordinary.

RANDOM RADIATIONS

The Time Difference

THE "all-wave" set (how I hate that misleading description!) has made the man-in-the-street pretty familiar with U.S.A. broadcast programmes, for several stations have been strongly received for some months now in the early evenings. W2XAD, for example, is as easy as shelling peas from about 5 p.m. onwards, and is usually at its best somewhere about seven o'clock. Many people therefore form their impression of American programmes from what they hear between, say, five o'clock and eight o'clock. That's rather a pity. These are the programmes transmitted between noon and 3 p.m. local time and they're certainly not the best that the U.S.A. stations can do. As a rule they are made up to a great extent of sponsored stuff and contain a great deal of advertising matter which, to us at any rate, seems deadly dull. Just as happens here, the evening programmes are the big things, and owing to the time difference you can't hear them unless you are prepared to begin operations at midnight and sit up into the small hours.

May I Suggest?

Here, for what it's worth, is a suggestion for the U.S.A. short-wave stations. The bulk of European listening to them takes place between 5 p.m. and 9 p.m. on the 19-metre band and between then and about 11 p.m. on higher wavelengths. That means a period of some six hours, corresponding to noon to 6 p.m. by local time. Instead of just relaying what was going from the medium-wave stations couldn't they put on special programmes? Why not, for example, Blattnerphone the main evening programme of the day before? American stations obviously want to be heard in Europe; some of them have made sure that they are heard by putting up and using directional aeriels. But Europe isn't going to listen to long "puffs" of products, many of which

aren't even known over here, unless it's very unsophisticated Europe giving its first "all-wave" set a run and in search of thrills rather than genuine entertainment. If we could have first-rate early-evening programmes from the U.S.A. short-wave stations they'd have a far bigger audience over here than any kind of directional aerial could ensure.

What is a Valve?

WIRELESS is full of queer and often quite inappropriate names for the apparatus which it uses. One of the most curious is "valve." It was, I imagine, first applied to the Fleming diode and for any diode or triode or pentode used as a detector it is good enough, since in these the unidirectional flow of current is the basis of the whole business of rectification. But it doesn't, somehow, seem too good a description of any kind of amplifier. The French are even less happy than we in their name—and this is unusual, since French is a language which prides itself on its exactness. They call it a "lamp," which was all very well in bright-emitter days (honest to goodness, a receiver was once produced with its five bright-emitters arranged in a chandelier!) but will hardly do now. In America the valve's early name was "audion," which suggested rather its audio-frequency uses and certainly would not fit in with AVC valves, oscillators, or squelch valves. The present-day American word is just "tube," which seems rather too general. Don't you think we need an international word that is worthy of so delicate and useful a piece of apparatus?

Improvement Needed

The valve has always been the Achilles' heel of the wireless set. In bright-emitter

days the filament, working at a very high temperature, was always liable to "blow up," and 90 per cent. of valves in those days came to a more or less untimely end through filament failure. The first dull-emitters were robust—I'm speaking of DER, DEV and DEQ—but they never became popular owing to their fantastic cost. The earliest dull-emitter to be widely used was the ".06" valve, which got its name from the fact that its filament required but 60 milliamperes of current. It wasn't a success because the cobweb filament was too fragile for ordinary use. Then came other battery valves with filaments needing from 0.1 to 0.25 ampere and they have proved their worth. The mains valve has always presented one big and very difficult problem: how to obtain and maintain efficient insulation between heater and cathode. Faults and breakdowns in battery valves are rare nowadays. At one time internal short circuits between the various grids of complex valves were not uncommon, but rigidly fixed electrodes have pretty well done away with that trouble. Even the microphonic valve—once such a nuisance—is not often found now. But the mains valve is still not as reliable as it should be, especially when one considers the price that we have to pay for it.

Hello, London!

THERE'S one very queer point in the October licence figures. London hitherto has always shown a bigish increase month by month, but for October there's a decrease and a substantial one. At the end of September 1,038,991 Londoners held receiving licences; at the end of October the total was down to 1,038,047, a reduction of 944. At first blush one might be tempted to think that here was proof that the saturation point had been passed; that a kind of boiling over had taken place. But I'm quite sure that that's not so, for, despite the London shrinkage, there was an increase of 59,953, or as near 60,000 as makes no matter, for the country taken as a whole. What, then, has happened to London? Can it be the recent decision at Marylebone Police Court that a loud speaker connected to a "community" receiver in a block of flats is not a receiving set and so need not be licensed? This is the time of year when big numbers of licences run out; London is largely a city of flat-dwellers; need we look any further for the explanation. As the "Flats Case" is to be the subject of an appeal I can't comment on it.

Hospitals and Television

NO, I'm not going to tell you how a doctor umpteen miles away may one day be able to examine your personal components by means of televised X-ray photographs. My purpose is to deal with the appalling interference that diathermy and other electrical therapeutic devices can cause with television reception. I want, too, to make a suggestion to those London hospitals that are in need of money—and that means most of them. Lately I've attended two television demonstrations, in both of which the images, after being perfectly clear and steady for some time, suddenly developed galloping St. Vitus's dance plus a kind of shimmy shake in a hailstorm. "Ah," sighed the demonstrator on each occasion, "It's that hospital again; I'm afraid it'll be like this for a quarter of an hour or so."

Random Radiations —

And it was. At the end of that time, or thereabouts, all became well again just as suddenly as it had become ill. Now, here's my suggestion for a way in which a good time may be had by all. Let the hospitals

make it known that they'll consult the interests of television viewers by refraining (except in cases of emergency) from using radiating apparatus between 3 and 4 and 9 and 10 p.m. and I'm sure they'll have some nice fat thank-offerings.

frequencies the tuned circuit is not a resistance and the balance is consequently upset. Thus all frequencies are passed on to the subsequent stages except that to which the circuit is tuned.

W. BAGGALLY, M.I.W.T.

Brighton.

Letters to the Editor

The Editor does not hold himself responsible for the opinions of his correspondents.

Valves

I WISH to record my personal thanks for your valve data issue of November 20th. I always find this annual list one of great value, and the extra information in this year's list, especially that dealing with valve capacities, makes the list invaluable to all serious amateurs.

Whilst I am in complete agreement with the suggestion that the multiplicity of types should be reduced by greater standardisation this, it seems to me, should be done very carefully. I notice one class of valve which already seems destined to disappear, viz., the low amplification triode having an AC resistance of 7-8,000 ohms. Your writer of the article on the valve data supplement mentions that the best valve for a grid detector or AF amplifier, from the point of view of quality, should have a resistance of 7,000-10,000 ohms.

The Osram MHL4 valve is a typical example and finds application in such an amplifier as the push-pull quality amplifier in the penultimate stage and also in the modified form of this amplifier used in the pre-tuned quality receiver.

The fact that the price of this class of valve is unchanged leads one to believe that manufacturers intend to discontinue them. Perhaps you could influence them to retain some specimens of this type at a price comparable to others, as there is nothing which quite takes their place in a quality receiver.

C. N. WILLS.

Weston-super-Mare.

WE have read with interest the letter from Mr. C. N. Wills, which refers to the Osram MHL4 valve.

It will be of interest to your correspondent and to other readers of *The Wireless World* to learn that there is no question of discontinuing manufacture of the MHL4 valve, but, on the contrary, this type is now available incorporating many modern mechanical features, although its electrical characteristics remain unchanged.

There is a demand in certain types of apparatus for a valve of the MHL4 characteristics, which are retained for this purpose, but the construction of the valve has been considerably improved by the introduction of electrode bonding and anchoring, dome bulb, etc., which make for better consistency, strength, and reduced microphony.

Due to existing tendencies in set design, however, the application of a valve with the characteristics of the MHL4 is limited to special cases, and the quantity manufactured is therefore extremely small when compared with other types which are in very large demand by the manufacturers of receiving sets. On account of the small-scale production the cost of manufacture is necessarily high, and it has not been found possible at the present stage, therefore, to reduce the price of this class of valve, as has

been done in many other types of broadcast valves.

THE GENERAL ELECTRIC CO., LTD.
Kingsway, W.C.2.

Rejecting Whistles

P. K. TURNER, in his article on "Rejecting Whistles," falls into so many errors in describing the action of my own whistle-eliminating circuit that it is manifest that he has himself failed to understand its action as set out in my *Wireless Engineer* paper (December, 1935). I shall be glad, therefore, if you will publish this letter so as to clear up any possible confusion in the minds of your readers on this topic. I will deal first with Mr. Turner's mistakes in the order in which they occur, and then give the correct explanation of the action of the circuit in non-mathematical terms: those who desire the correct mathematical theory are referred to my original paper.

Firstly, then, the circuit diagram (Fig. 8) is wrongly drawn: the lead going to the next valve *via* the grid condenser should connect to the junction point of the variable condenser and resistance, and not to the anode as shown.

Secondly, there is no question of negative feed-back being used. A moment's thought will show that it is impossible to reduce the output of a device to zero by the use of negative feed-back, for in that case there would be nothing to feed back, so that at zero output the feed-back circuit would be inoperative and so could not reduce the output to zero.

Thirdly, the argument of Appendix II is invalidated by the fact that Mr. Turner has misinterpreted the meaning of my R in equation (8) of my paper. This R is not, as he assumes, the same as his R'a, but is, in fact, roughly equal to this latter in series with the resistance running from variable condenser to anode, which latter is of the order of 10,000 ohms in practice. The only reason why it is sometimes desirable to cut down the gain of the stage incorporating the filter is connected with questions of band-width, and has absolutely nothing to do with the minimum output (which is always zero, no matter what the stage-gain may be).

The correct explanation of the action is as follows: The AC components of the grid voltage and anode voltage are in phase opposition; from which it follows that if a non-reactive resistance be connected between grid and anode, there will be a point on this resistance whose potential with respect to the cathode is zero: if a tuned circuit be substituted for the portion of this resistance between grid and zero-point, the conditions will be undisturbed provided the circuit is in resonance with the applied frequency and has the right value of resistance, since a tuned circuit acts as a pure resistance at the resonant frequency. But at all other

I MUST apologise to Mr. Baggally for having misrepresented him in my recent article, but at the same time he must bear part of the responsibility, for my comment on his system was based on a very careful study of his article in the *Wireless Engineer*. Not only did I study it, but I checked over the whole of the analysis and extended it in some respects for my own satisfaction. If, then, I completely misunderstood him, either I must be a complete ass, or his original article could not have been quite clear; and I refuse to admit the former alternative.

I might add that not only did I study his article and check the analysis, but I put the system into operation and found exactly what I have stated in my article.

P. K. TURNER.

Flex Lead Suppressors

IT is often more convenient to insert a suppressor in the connecting lead to a portable electrical device than to mount it on the device itself; it is for that reason that Belling & Lee produce suppressor units of suitable shape and with sufficient mechanical strength for use in the former manner.

The "two-core" pattern, for connection to appliances wired with twin cable, is well known; the three-core type, a later introduction, is housed in a neat bakelite casing of somewhat similar appearance, and in addition to a pair of condensers contains a 2,000-microhenry choke. Three-core suppressors are used, of course, on devices connected by "live," neutral and earth wires.

The Belling-Lee three-core flex suppressor. An interference-



suppressing device of this kind is inserted in the flexible connecting lead, as close as possible to the source of interference.

There has lately been some discussion on the permissible resistance of the choke, which, in three-core suppressors, is connected in the earthing lead. In the Belling-Lee device, the ohmic value has been kept down to such a low value that the total circuit resistance to earth under conditions arising when a fault exists should not exceed 5 ohms. Thus the frame of the appliance should never reach a dangerously high potential. Suitable precautions have been taken elsewhere in the design to minimise risk in the event either of a dead "short" or a leakage.

Listeners' Guide for the

THE spirit of Christmas pervades the programmes throughout this week, the B.B.C. having devoted more than usual attention to the choice of seasonal material.

On Tuesday the St. Hilary Players will again broadcast from St. Hilary's Church, Bernard Walke's vision of Christmas, "The Stranger at St. Hilary."

Seasonable airs and carols of many nations will be broadcast by the Leslie Bridgewater Quintet, with Constance Carrodus (contralto) as soloist, from the National station at 10.10 on Wednesday.

A shortened version of Robin Whitworth's pageant of Christmas, "Unto Us," which was broadcast last Christmas Day, will be heard, as "Unto Us a Child is Born," by National listeners on Christmas Eve at 9.20. It will be remembered that it includes passages from the Bible and from the works of Arnold Blake, Chesterton, Gwent-Johnson, De la Mare, Shakespeare and Tennyson. Music is played by Section C of the B.B.C. Orchestra from well-known compositions of Handel, Haydn, Parry, Warlock, Hely-Hutchinson, and others.

Subject to weather conditions being favourable, the annual Carol Service from St. Mary's, Whitechapel, will take place in the churchyard at 8 (Reg.) on Christmas Eve. This is essentially a B.B.C. Christmas broadcast, for the "Waits" will be the B.B.C. Chorus and members of the Military Band. During the broadcast the vicar, the Rev. Prebendary J. A. Mayo, will give a three-minute address. Should the weather be unsuitable the service will be held in the church. The annual carol service from King's College, Cambridge, will be heard by National listeners during the afternoon.

REVUE

The monthly revues, which were discontinued when the Variety Director went on holiday earlier in the year, will be revived on Tuesday, and judging from the title, "Folly and Mistletoe," should have a real

Christmassy flavour. It will be heard at 10 (Reg.), and includes many well-tryed favourites. All the sketches, etc., have been written from a seasonable angle.

STAR GAZING

THE second of the series of broadcasts under this heading will be given to listeners tonight (Friday) at 8 (Nat.) and on Saturday at 4.15 (Reg.). It features José Collins, the



famous actress and daughter of Lottie Collins. She started her stage career as a child and was Harry Lauder's original Scottish Bluebell. Miss Collins scored her greatest triumph as the Maid of the Mountains in the successful musical comedy of that name.

THE SECOND TEST

ALAN KIPPAX will again be heard giving eye-witness accounts of each day's play in the second Test Match between Australia and the M.C.C. at Sydney. At 8.30 a.m. today, Saturday, Monday and

Tuesday he will give his commentary, and at 1 each day a record of the account will be broadcast.

A FAMOUS RIDE

IN 1925 Aimé Felix Tschiffely began a ride from Argentina which ended nearly three years later in New York. This feat of horsemanship and endurance is all the more wonderful when it is remembered that he used the same two horses throughout. Laurance Gilliam has built a programme around this epic ride, in which Tschiffely himself will be heard, assisted by his wife, Violet Marquesita, the famous



HORSEMANSHIP. A. F. Tschiffely and his wife who will be heard in the National programme on Sunday. Inset are the two horses, Mancha and Gato which were used for Mr. Tschiffely's ride. They are shown in a dry river bed in Bolivia.

actress and singer. Records of South American music will form the background to what should prove an interesting and exciting broadcast, to be heard by National listeners at 9.5 on Sunday.

VARIETY

THE mid-week variety which will be heard Regionally on Wednesday at 8 includes Claude Hulbert and Enid Trevor, Elizabeth Welch, Jeanne de Casalis and Jean Sablon. With such brilliant artistes this should be well worth listening to.

DANCE MUSIC FROM BERLIN

AMONG the foreign items last week I drew attention to the broadcast from Deutschlandsender by the German dance band leader, Barnabas von Geczy. Listeners will have another opportunity of hearing him with his orchestra in a relay from Berlin of a programme of light music, "Melody and Rhythm," on Sunday from 6-6.30 (Reg.).

STREET SHOW

CHRISTMAS shoppers and sightseers in London are treated to a variety of entertainments in the highways and byways of the great Metropolis. In an half-hour's programme on Monday at 8 listeners will be entertained by a selection of these in a studio broadcast.

GANGSTERS

A NEW radio thriller has been written by Hector Stewart and Ray McLoughlin called "Men from the Other Side," which will be broadcast on Monday at 8.30 (Reg.) and again on Wednesday at 9.35 (Nat.). The story is written around a gang of American crooks who form a night club in London in 1936. The Effects Department will be in its element for this broadcast, which includes such noises as breaking glass, machine-gun fire, and the overturning of tables and chairs.

HOROLOGY

THIS year is the bi-centenary of the marine chronometer, and on Thursday at 6.20 (Nat.) Lieut. - Commander Gould, who is a favourite broadcaster in the Children's Hour under the pseudonym of "The Star Gazer," will give a talk about Harrison and his clocks which should appeal not only to horologists, but to everyone.

It was in 1736 that John Harrison's No. 1 machine, the first accurate marine time-keeper, was successfully tested at sea in H.M. ships *Centurion* and *Orford*. Until then no practical method of finding longitude at sea had been devised.

Details of the week's Television programmes will be found on p. 640.

Week

CONTEMPORARY MUSIC

A CONCERT version of Paul Hindemith's opera "Cardillac" fills the programme of the third of the series of Contemporary Music Concerts which will be broadcast to-night at 9.40 (Nat.). Paul Hindemith is one of the most distinguished composers of the younger generation in Germany to-day. The performance will be conducted by Clarence Raybould, and the singers include Arthur Fear, Miriam Licette and Dennis Noble.

TRAIN BROADCAST

THE conversation between a traveller in a German train and a traveller in an American train, carried out by means of a short-wave link, was broadcast from the N.B.C. stations



WOMAN COMMENTATOR. Thelma Carpenter, who will describe the women's billiards championship match which comes in the Saturday Contrasts.

HIGHLIGHTS OF THE WEEK.

FRIDAY, DECEMBER 18th.

Nat., 5.15, The Continentals. 8, Star Gazing No. 2—José Collins. 9.20, "Free Air"—a Talk on the Problems of International Flying. 9.40, Contemporary Music Concert.

Reg., 6, The Bighouse and Rastrick Band. 7.30, Carroll Gibbons and the Savoy Hotel Orpheans. 8, B.B.C. Orchestra (E) with Nicholas Tschaikow (clarinet). 9, Trinity House Programme.

Abroad.
Hilversum, 7.45, Bach Society's Concert.—Utrecht Municipal Orchestra.

SATURDAY, DECEMBER 19th.

Nat., 3, Saturday Contrasts—No. 4. 6.45, The Scots Military Ex-Guardsmen's Band. 7.30, "In Town To-night." 9.20, Music Hall.

Reg., 4.15, Star-Gazing No. 2—José Collins. 7.30, The Gershwin Parkington Quintet. 9, Biography of Admiral Cochrane.

Abroad.
Kalundborg, 7-12, "Two Centuries of Song and Dance."

SUNDAY, DECEMBER 20th.

Nat., 5.20, Chamber Music—Reginald Kell (clarinet) and the Kitcher String Quartet. ¶Fred Hartley and his Novelty Quintet. 9.5, Tschiffely's Ride.

Reg., 5, Erith British Legion Band. 6, "Melody and Rhythm" relayed from Berlin. 6.30, Sunday Orchestral Concert—X. 9.5, Recital—Peter Dawson.

Abroad.
Hamburg, 7, "Christelflein"—Christmas Fairy Opera (Pfitzner).

MONDAY, DECEMBER 21st.

Nat., 6.20, Kentucky Minstrels. ¶The Music Shop. 8, Street Show. 8.30, Solomon.

Monday, December 21st (cont.)

Reg., 7.30, Midland Orchestra—"Rhapsody." 8.30, "Men from the Other Side." 9.35, Scottish Dance Music.

Abroad.
Radio-Paris, 8.45, Conservatoire Concert by Ex-Students.

TUESDAY, DECEMBER 22nd.

Nat., 6.25, The B.B.C. Orchestra (E) and Jan van der Gucht. 7.20, B.B.C. Dance Orchestra. 8, "The Stranger at St. Hilary." —The St. Hilary Players. 10, "Folly and Mistletoe."

Reg., 6, Reginald King and his Orchestra. 6.40, The London Theatre. 9, "Pageant of Pantomime."

Abroad.
Deutschlandsender, 8, Berlin Philharmonic—conductor, Hans Pfitzner.

WEDNESDAY, DECEMBER 23rd.

Nat., 7.30, Melody out of the Sky—Jay Wilbur and his Band. 9.35, "Men from the Other Side." 10.10, Tunes of Christmastide.

Reg., 7.30, The World Goes By. 8, Variety. 9, B.B.C. Theatre Orchestra.

Abroad.
All German Stations. 7.15, Youth Winter Solstice Programme.

THURSDAY, DECEMBER 24th.

Nat., 8, Van Phillips and his Two Orchestras. ¶Strange to Relate. 9.30, "Unto Us a Child is Born."

Reg., 6, Upper Norwood Salvation Army Band. 8, Carol Service from St. Mary's, Whitechapel ¶Violin Recital, Paul Beard. 9, The Kentucky Minstrels.

Abroad.
Hamburg, 4.30-11, "Under the Christmas Tree"—Musica Sketches, Chimes, Carols and Band Concert.

Outstanding Broadcasts at Home and Abroad

on November 8th. Recordings of this extraordinary feat are to be broadcast from Munich at 9.20 on Monday, and as the conversation is in English it will be well worth listening to.

CHRISTMAS EVE

ALL German stations at 8 on Christmas Eve will broadcast the address of Herr Rudolf Hess, the deputy of Herr Hitler, at 8 when he speaks to German people at home and abroad. Following this at 8.20 German churches will ring in Christmas.

During the broadcast from Hamburg of "Under the Christmas Tree," which will occupy the programme from 4.30 to 11, a play by Breyholdt, after Dickens' "A Christmas Carol," will be broadcast at 10.10.

A RARE INSTRUMENT

DURING the broadcast from Leipzig on Wednesday at 8 of a musical play with the curious title, "Luck in Glass," Gerhard Nauwerck will play the glass harp, a rare instrument.

OPERA

THE most important transmission under this heading for Friday comes from Leipzig at 6.15 and lasts until 9. It is a gala performance of Weber's "Der Freischütz"—a transmission which will be taken by many stations on both sides of the Atlantic. Listeners are assured of an excellent rendering, for Hans Weisbach will be conducting the Leipzig Symphony Orchestra

FREDERICK BAYCO will be heard at the Theatre Organ during the "Melody Out of the Sky" programme on Wednesday at 7.30 (Nat.).



and the Station Chorus, and there will also be a distinguished cast.

The 8.45 transmission from Radio Paris on Saturday shows a continuance of the French policy—the support of national composers. The programme commences with a concert version of Magnard's "Berenice." Magnard's music is austere in character, which probably explains why

his works remain untried and practically unknown outside his native land. He was killed during the War and his house burned, and the only existing copies of a number of his compositions, including the original scores of his "Yolanda," were destroyed. Radio Paris draws upon the works of a living composer for the completion of this programme, this being Act I of Maurice Emanuels "Salamine."

From Sunday onwards even in the opera programmes the spirit of Christmas is prevalent. Hamburg's contribution at 7 is Pfitzner's fairy opera, "Christelflein," a hardy annual, always worth hearing.

Frankfurt announces an opera for 7.10 on Tuesday which is likely to be of great interest to English listeners, since it is based on Mary Tudor, Queen of England. The composer, Herr Wagner-Régeny, is one of the ultra-modern German school whose works are exceedingly acceptable to post-War Germany. The title of this three-act opera is "The Favorite," and the station musical director, Herr Rosbaud, is responsible for the studio production.

Radio Paris provides us with by far the most important foreign transmission of Thurs-

day with its 8.45 performance of Berlioz' "L'enfance du Christ"—an oratorio so well known that its bare announcement is more than sufficient to ensure it a very wide hearing, particularly as responsibility for the interpretation is in the excellent hands of Inghelbrecht, conducting the National Orchestra, the Virgin being sung by Mme. Martinelli.

THE AUDITOR.

New Apparatus

Reviewed

Recent Products of the Manufacturers

VIDOR SHORT-WAVE CONVERTER

THIS is an inexpensive unit developed by Vidor, Ltd., West Street, Erith, Kent, for use with any battery-operated broadcast set to extend the range so that the short waves can be received. It can be used with either straight or superheterodyne sets, though in the case of the former type it is essential that at least one RF stage be available.

The unit is quite easy to fit as, being a superheterodyne converter, its output is fed into the aerial circuit of the broadcast set so that all connections are made to existing terminals, and there is no need to look for contact points inside the cabinet, unless the

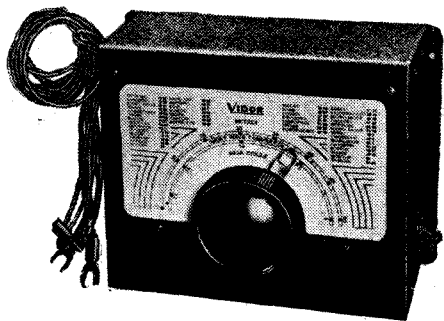

Battery-operated short-wave converter made by Vidor.

batteries are housed there; for the HT and LT supply for the unit can be taken from the set's batteries.

Tuning is quite simple as there is only one wave-range, which covers 13 to 50 metres, but as it takes in all the principal short-wave broadcasting bands it suffices for most purposes.

Using a popular type of receiver, viz., a small superheterodyne, all the high-power European short-wave stations were easily tuned in, and from time to time several of the American stations were heard at good strength.

As only the oscillator circuit is tuned and the aerial circuit is aperiodic on the short waves, some interference is inevitable, and occasionally signals are received on harmonics of the oscillator. Thus, a station working in the 19-metre band may be heard when the oscillator is tuned to 38 metres or thereabouts. However, this is not usually very troublesome, and there is no way of avoiding this without considerable elaboration, which, of course, would mean a big increase in the cost.

The unit undoubtedly serves its purpose well, which is to provide means for receiving the short waves in the cheapest possible manner.

Though costing only 47s. 6d., it is very well made and neatly finished. It is housed in a metal case measuring 6½ in. by 5½ in. by 3½ in. high overall and is fitted with a good slow-motion condenser drive.

On the whole it is a very satisfactory unit at the price.

C.A.C. ALL-WAVE SUPERHET COIL UNITS

SINCE preparing the review of the above coil units, which appeared in our issue of December 4th, information has been received that the complete outfit as supplied by the City Accumulator Co., Ltd., for 52s. 6d. includes, in addition to the coil units, two Litz-wound 456 Kc/s IF transformers, one of which has three tuned circuits, and also a local station filter.

FULLER SPARTA BATTERY

THE Fuller dry-battery with which our tests have been made is a standard capacity model of 120 volts and known as the Type F25. Conforming with usual practice the battery was discharged through a resistance, the value of which was such that at the commencement it allowed the maximum permissible current of 8 mA to flow.

Intermittent discharge was effected; this was arranged automatically, and allows for periods of four hours' working, followed by similar periods for recuperation.

On the graph giving the discharge curve only the actual working hours are shown, and the end-point is an arbitrary one which coincides with a voltage of 0.75 per cell. As this battery contains 80 cells it represents a battery voltage of 60.

Under these conditions of test the battery gave 400 working hours, which is a little above the average for this class of battery. Its total capacity to the end-point is 135 watt-hours, which gives 1.7 watt-hours per cell, a good performance for the size of the cell used in this battery.

The most interesting feature about the curve, however, is the high level maintained throughout the working period.

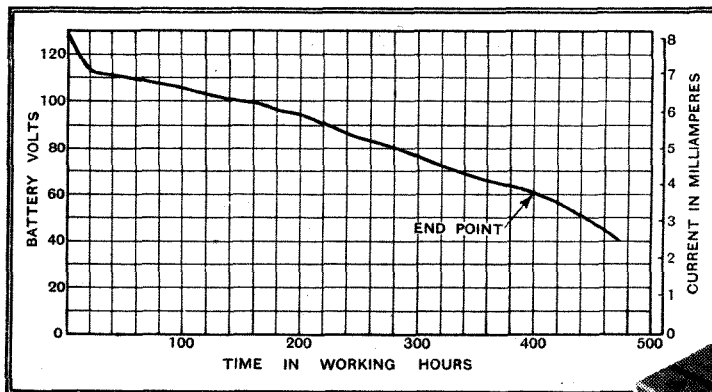

Discharge curve of Fuller Type F25 120-volt battery which reveals an effective life of 400 working hours when the maximum discharge current does not exceed 8mA.

The initial fall is not very pronounced even at the high rate of discharge chosen, and the voltage remains above the 100 mark for about 160 hours. For a voltage drop of this order, and assuming three hours' use per day, it will give 54 days' service. As, however, the recuperation periods will be much longer than allowed in this test, it might quite well serve for about two months before the voltage drops below 100, and even then the battery has not reached the end of

its usefulness, but will continue to operate the set, possibly with a somewhat reduced power output, for quite a long time to come.

The Type F25 is tapped in 12-volt steps. It costs 7s. 6d., and is made by the Fuller Accumulator Co. (1926), Ltd., Chadwell Heath, Essex.

RADIOMETERS VALVE TESTER ADAPTOR

SINCE the introduction of the Radiometers Allvalve Tester many new valves have come into use, and though the test set con-

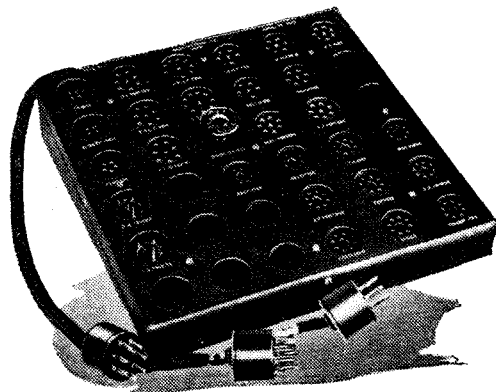

Adaptor unit produced by Radiometers for use with their U.V.T. Allvalve Tester.

tains 36 valveholders, all with different socket connections, it does not now suffice for all the valves available.

In order to extend its scope, Radiometers, Ltd., Dunbar Works, Dunbar Street, London, S.E.27, have produced a unit in the form of another valve panel having provision for a further 35 valveholders. This is connected to the main testing panel by a cable and a multi-pin plug, which supplies HT, LT and inserts the metres in the various circuits for testing purposes.

Only 27 of the 35 socket holes are fitted with valveholders, the blank sockets being for future needs. When new valves appear it is the makers' intention to supply wiring diagrams and valveholders for the panel so

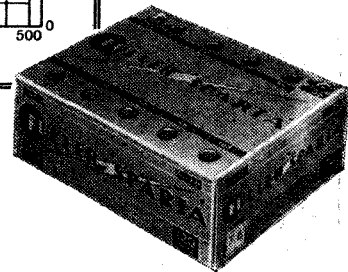

that the valve-testing set will always be right up to date.

The adaptor panel costs £3 13s. 6d.

Resistance-Coupled Amplifiers

PART V.—VALVE OPERATING CONDITIONS

THE method of operation of the resistance-capacity coupled amplifier and the choice of circuit values for the avoidance of frequency distortion have been fully treated in this series of articles, and it remains to deal with the selection of the operating conditions of the valve from the point of view of avoiding amplitude distortion. A valve is popularly supposed to have certain constants—AC resistance, amplification factor, mutual conductance—but actually it has not, or they hold only over a limited range of voltages.

The three so-called constants actually depend upon the voltages applied to the electrodes of the valve, and vary appreciably when the operating conditions are changed. When they vary during the cycle of input voltage which it is desired to amplify, amplitude distortion occurs, and it is important to make sure that over the range of input voltages likely to be encountered the variations are negligible. These "constants" are also used in the equations employed for calculating frequency distortion, and as they are likely to vary it is important to use the values holding for the particular operating voltages which will be adopted.

In this connection it must be remembered that the valve maker's figures are hardly ever the correct ones to use in the equations. In the case of triodes the figures are always quoted for an anode supply of 100 volts and zero grid potential—conditions hardly ever adopted in practice. The figures are consequently only useful in comparing different valves. It generally happens, however, that the amplification factor does not vary much with the operating conditions, and that under the usual conditions for an LF amplifier the AC resistance is about 25 per cent. higher than the maker's figure. In the absence of exact data, therefore, the maker's rating for μ may be taken and 25 per cent. added to his figure for AC resistance, and these values employed in the equations without any serious error. These remarks do not apply to tetrodes and pentodes.

Bias Resistance Lines

For accurate design, of course, anode-volts—anode-current curves are necessary, and accurate figures for the valve constants under any conditions can naturally be obtained from these. At the moment, however, we are concerned chiefly with the question of amplitude distortion. The method of dealing with this is most readily shown by considering a concrete

case. Let us suppose that we are intending to use an MHL4 valve with a coupling resistance R_1 of 25,000 ohms and a grid leak R_2 of 250,000 ohms, that our HT supply is 290 volts, and that we require an undistorted output of 35 volts peak.

To choose suitable values of components for the avoidance of frequency distortion, which has been dealt with in the earlier articles in this series, is only to complete half the design of an amplifier. If amplitude distortion is to be avoided, the valves must be operated correctly, and in this article the use of valve curves is explained

Fig. 12.—A set of anode-volts—anode-current curves for the MHL4 valve with a variety of load and bias resistance lines.

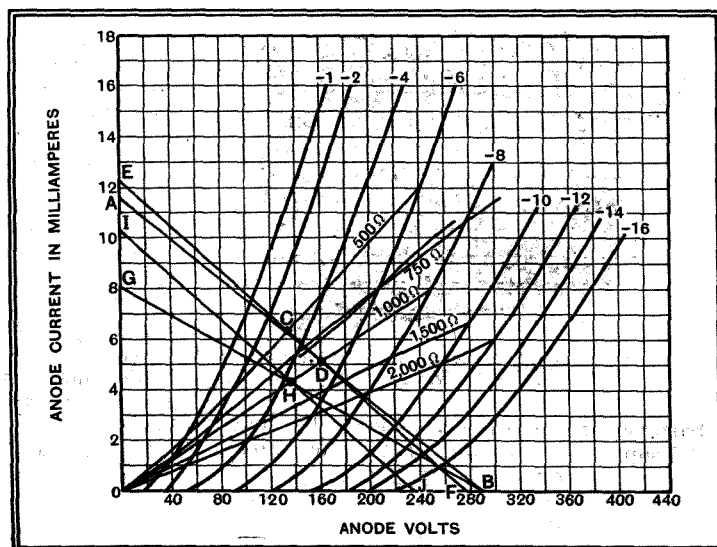

The valve curves are shown in Fig. 12, and adopting the procedure described in Part I we draw the line AB from 290 volts to represent the DC conditions for a 25,000-ohms resistance in the anode circuit. Now, as we shall use automatic grid bias derived from a resistance in the cathode circuit, since the valve is of the indirectly heated type, it is not convenient to choose a definite grid bias and then to use the resistance which will give this bias, for this will usually lead to a non-standard value of resistance. The grid bias is not often very critical, and it is much easier to choose a standard value resistance which will give approximately the right bias. We proceed, therefore, to draw a number of lines on the valve curves to represent a number of different resistance values, say 500, 750, 1,000, 1,500, and 2,000 ohms. These lines are plotted between the grid-volts curves and the current scale, and they are not necessarily straight. For each grid-voltage curve, calculate the current which would flow if that voltage were applied to the resistance: thus, for a 1,000-ohm resistance there

would be 1 mA. at 1 volt, 2 mA. at 2 volts, 3 mA. at 3 volts, and so on. Then join the points of intersection of the grid-volts curves with these currents. These are shown in Fig. 12 by the lines radiating from the zero point.

The intersections of these lines with the load line AB fix the operating points of the valve for the different resistances. If we choose a 500-ohm bias resistance, then with the 25,000-ohm load resistance and 290 volts HT supply we operate at the point C with an anode current of 6.3 mA., an anode potential of 134 volts, and a grid bias of 3.15 volts. Inspection of the diagram shows that the most likely values of bias resistance are 1,000 ohms and 1,500 ohms. Let us, therefore, try 1,000 ohms.

The operating point is D, the anode current 5.15 mA., the anode potential 161 volts, and the grid bias 5.15 volts. It should be noted that strictly speaking the HT supply should be 295.15 volts for this condition, since the bias must be deducted from the HT supply. In cases like this, where the bias voltage is only a few per cent. of the HT supply, the error introduced by ignoring this factor is negligible.

The A.C. Load Line

Now, although we have a load line AB, this line does not apply to AC conditions, for it represents only the DC load on the valve. The AC load on the valve is $R = R_1 R_2 / (R_1 + R_2)$, in this case 22,750 ohms. We must, therefore, draw a new line EF, representing this resistance through the operating point D, and this new line enables the AC conditions to be determined.

Instead of trying to determine everything directly from the diagram of Fig. 12, however, it is easier and more accurate to plot a new curve—the dynamic grid-volts—

Resistance-Coupled Amplifiers—

anode-volts curve. This is done by plotting the intersections of the AC load line EF with the grid volts curve, and the result for this case is shown in Fig. 13. The curve A is not straight throughout its length, so that distortion will occur if the signal voltages extend into the curved regions. The operating point is D for an anode potential of 161 volts. For an output of 35 volts peak the anode voltage should swing over the range 161 ± 35 , or from 126 volts to 196 volts. The diagram shows that the anode potential is 126 volts when the grid potential is -2.5 volts; since the normal grid bias is -5.15 volts, this corresponds to a change of grid potential of $5.15 - 2.5 = 2.65$ volts.

During the negative half-cycle of input the grid potential will change in the opposite direction by the same amount, so that it will reach $-5.15 - 2.65 = -7.8$ volts, and for this the anode potential will be 196 volts. This happens to be the correct figure to make the positive change of anode voltage equal the negative, consequently no distortion is introduced, and the operating conditions which we have chosen are entirely suitable. The stage gain is, of course, $35/2.65 = 13.2$ times.

Second Harmonic Distortion

The maximum output of which the valve is capable is limited by two factors. It will be observed that the curve of Fig. 13 is straight up to about -8 volts, but commences to bend when the grid voltage becomes more negative than this. If the signal voltage runs the grid into this region distortion will occur, and this places one limit to the maximum undistorted output obtainable. In the other direction the curve is straight, but grid current will flow if the grid potential is not sufficiently negative, and distortion, and possibly blocking, will again occur. The precise point at which grid current commences depends on the valve design, and is usually at about -1 volt with indirectly heated specimens. To be completely safe it is perhaps wise to design so that the grid is never less negative than -1.5 volts, but in general it is possible to work up to -1 volt.

Accepting this limit, the maximum input which can be applied to the valve operating under the conditions for which Fig. 13 has been derived is 4.15 volts peak, so that the grid potential swings between -1 volt and -9.3 volts. This causes the anode voltage to oscillate between 107 volts and 212 volts, the normal voltage being as before, 161 volts. We see that for the positive half-cycle of input, that is, the change from -5.15 volts to -1 volt, the anode potential changes from 161 volts to 107 volts, the magnitude of the change being $161 - 107 = 54$ volts. On the negative half-cycle of input, however, the magnitude of the change is only $212 - 161 = 51$ volts. The valve is being worked somewhat beyond the linear portion of its characteristic. Some distortion is consequently introduced, and the magnitude of

the second harmonic is given approximately by the formula

$$\text{Distortion (\%)} = \frac{100}{EMAX - EMIN} \left[\frac{(EMAX + EMIN)/2 - ENOR}{EMAX - EMIN} \right]$$

where the voltages are the maximum, minimum and normal values of anode voltage as read off from a curve such as that of Fig. 13. Applying this formula to the case under discussion, we have

$$\text{Distortion} = 100 \left[\frac{(212 + 107)/2 - 161}{212 - 107} \right] = 1.425 \text{ per cent.}$$

This is not a large amount of distortion, and it would often be considered unimportant. It is higher than one should tolerate in an LF stage when the highest quality is required, however.

At this point it may be pertinent to enquire what factors affect the maximum output obtainable. In the first place, grid bias is important. We have seen that there is a certain grid voltage at which grid current commences; with a given valve, HT voltage, and load impedance, there is another grid voltage at which the dynamic grid-volts-anode-volts curve commences to bend appreciably. The optimum grid bias is midway between these two points.

The second point of importance is the load resistance. There is no optimum value, and the output tends to increase indefinitely as the load resistance is raised. Naturally this applies only when a voltage output is required; it is not true when maximum power is required. This is also true only when the departures from linearity are due to variations in the AC

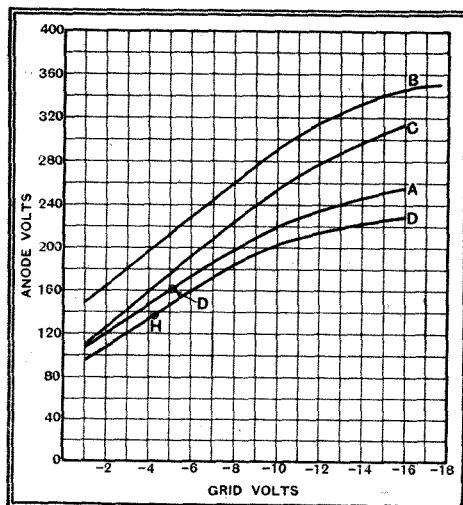

Fig. 13.—The dynamic characteristics of the MHL4 for certain operating conditions explained in the text.

resistance of the valve; it does not apply when it is the amplification factor which varies. We have seen that the stage gain is given by $A = gr$; this can be written in the form

$$A = \frac{\mu R}{R + R_a}$$

It is easy to see that if R_a varies with voltage, A will also vary with voltage, but to a smaller degree, provided that R and R_a are comparable in value. It is equally easy to see that when R is very much

larger than R_a (say $R = 100 R_a$), A is very nearly constant. It is clear, however, that if μ varies, then A must also vary irrespective of the value of R .

The amplification factor of triodes is usually fairly constant, but it is likely to change most when the anode current is very low, and a variation is more to be expected in valves of high mutual conductance than in those having only a moderate value of g . In general, therefore, the use of too high a value of load resistance is to be avoided, and under ordinary circumstances it is wise to make the resistance not greater than ten times the valve resistance. It is much better to err on the high side rather than the low, however, and under no normal circumstances should the load be less than twice the valve resistance.

The Output Obtainable

The output obtainable always increases as the anode voltage is raised, provided that one keeps within the rating for the valve, but it does not vary greatly with the type of valve. This statement may seem rather surprising. Ideally, the output would not vary at all from valve to valve, but in practice the output does tend to be greater with valves of low resistance than with high-resistance valves, because the low-resistance valves tend to have straighter characteristics. Valves of moderate g also tend to give a larger output than more efficient types, for the same reason. Thus, considering the MH41, MH4, MHL4 and ML4 valves, we should expect the output to increase in that order, and in fact it does tend to do so. The MH41 has both a higher mutual conductance and a higher AC resistance than the MH4, but its characteristics are not quite so straight. Similarly the MH4 and the MHL4 have nearly the same resistance but the former has the higher amplification factor, and is rather the less linear. The ML4 is of much lower resistance than the MHL4, but it has a higher mutual conductance. The writer has no special information regarding this valve, but its maximum output is unlikely to be appreciably different from that of the MHL4. It is not a very suitable valve for resistance coupling in view of the low gain obtainable and the high anode-current consumption.

Before concluding this section, it may be of interest to derive the conditions for a larger output. Suppose we want to feed a PX25A valve requiring 100 volts peak input; with a 500-volts HT supply and a 25,000-ohm load resistance the optimum condition is with a 750-ohm bias resistance, and the dynamic curve B of Fig. 13 is obtained. For 100 volts peak output on the positive half-cycle of input, the input is 6.2 volts peak, and there is 5.86 per cent. second harmonic distortion. If with the same HT voltage, however, we use a load resistance of 50,000 ohms we get the dynamic characteristic C of Fig. 13 and we can obtain an output of 100 volts peak with only 0.495 per cent. dis-

Resistance-Coupled Amplifiers—

tortion. The optimum grid bias is 7.8 volts and a bias resistance of 1,325 ohms is required.

In the foregoing no allowance has been

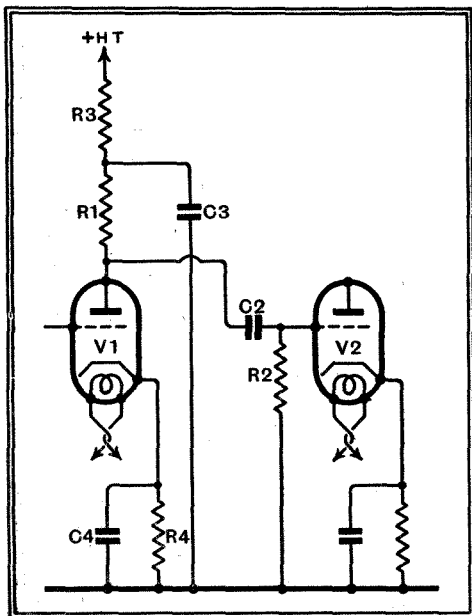

Fig. 14.—When computing the load, care must be taken to include all components relevant. The DC load is $R_1 + R_3$, but the AC load is R_1 in parallel with R_2 .

made for any decoupling. When this is needed it will inevitably cause a loss of voltage, so that if the same output is to be maintained a higher HT voltage will be needed. Referring to Fig. 14, the DC load line is for $R_1 + R_3$ (strictly, $R_1 + R_3 + R_4$, but R_4 is usually small enough to be neglected), while the AC line to be drawn

through the operating point is for R_1 and R_2 in parallel. Let us apply this in the case previously discussed for an HT supply of 290 volts, and let $R_1 = 25,000 \Omega$, $R_2 = 250,000 \Omega$, and $R_4 = 1,000$ ohms as before. Let us say that $R_3 = 10,000$ ohms will provide adequate decoupling. Then the DC load line must be drawn for a total resistance of $25,000 + 10,000 + 1,000 = 36,000$ ohms, and it is shown by the line GB in Fig. 12. The AC load line is the same as before, 22,500 ohms, passing through the operating point H at the intersection of the DC load line and the bias resistance line; it is the line IJ.

The dynamic characteristic can now be drawn and is shown by curve D in Fig. 13. The operating point corresponds to an anode potential of 136 volts, the anode current and grid bias being 4.35 mA. and -4.35 volts respectively. The maximum peak input is thus 3.35 volts, causing the anode voltage to swing between 95 volts and 180 volts. The output on the positive half-cycle of input is 41 volts, so that the gain is $41/3.35 = 12.2$ times. The distortion is 1.78 per cent.

Comparing these figures with those for the same valve without the decoupling, we find that the maximum input is 3.35 volts peak instead of 4.15 volts peak, and that the output is 41 volts peak instead of 54 volts. The amplification is 12.2 times as compared with 13 times, owing to the AC resistance of the valve being slightly higher at the lower anode voltage, and the distortion is 1.78 per cent. instead of 1.425 per cent. Evidently decoupling resistances should be no higher than are necessary for the avoidance of feed-back effects.

BOOK REVIEWS

Mathematics for the Million. By Lancelot Hogben. 648 pp., 200 illustrations. Second impression. George Allen and Unwin, Ltd., 40, Museum Street, London, W.C.1. Price 12s. 6d.

HOW mathematics has developed from the individual to the social, from a man counting on his fingers to the printing of log-tables, and according to our practical needs is the main motif of Prof. Hogben's book. While in hospital it was written "for fun," and we should be grateful to the friends who insisted on its publication. Every wireless man should have some maths., and here is a most attractive introduction which cannot fail to encourage the student to search farther. At the same time there is much entertainment included for those who are using figures every day of their lives, and they need not be put off by the "popular" title. Just as mechanical systems can be illustrated by electrical symbols, the author incidentally explains the non-mathematical way of thought to mathematicians. Readers are warned to make a note in passing of the folios that interest them particularly as there is no index. There is on page 106 (c) such an obvious error that quite possibly it was left in as part of the exercise. The experimenter who calculates his longitude from the Greenwich pips and a sundial might be disappointed with the result, but it should not take him long to discover why. In the writer's own words, "What you get out of

this book depends on your co-operation in the social business of learning." G. S.

Walls Dictionary of Photography. Edited by F. J. Mortimer, Hon. F.R.P.S., Editor of "The Amateur Photographer and Cinema Photographer" and of "Photograms of the Year." 636 pp. with numerous diagrams. Published by Iliffe and Sons Ltd., Dorset House, Stamford Street, London, S.E.1. Price 7s. 6d.

THE fourteenth edition of this well-known book has just been produced. Although it derives its name of dictionary from the fact that its contents are arranged in alphabetical order, it is actually a very complete reference book, invaluable to the professional no less than to the keen amateur photographer. The present edition has been brought completely up to date and deals fully with the latest developments in both still and ciné photography.

Collins' Diaries

IN the series of Collins' Diaries for 1937 are included the "Engineer's" Diary, the "Electrical Engineer's" Diary and Collins' "Wireless" Diary. All three productions, in addition to the Diary pages, include a very large amount of useful technical reference material.

MCCARTHY
for the finest value in
All-Wave Receivers!

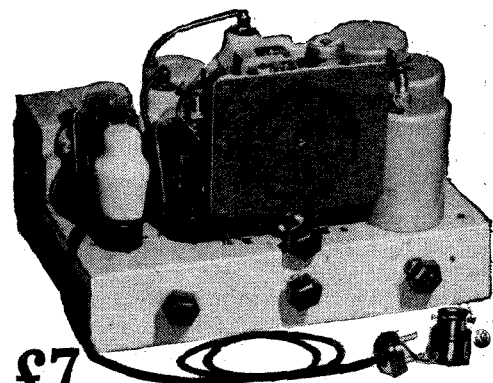

£7
6 VALVE ALL-WAVE SUPERHETERODYNE

(complete with B.V.A. Valves)

Improved edition of this popular receiver (praised "Wireless World" test reports). Heavier gauge cadmium-plated steel chassis. Iron-cored I.F. transformers give even better performance. No increase in price.

Brief Specification: 8-stage, all-wave band-pass superheterodyne, 7 tuned circuits. D.A.V.C. with "squelch" circuit valve for noise suppression. Illuminated "Airplane" dial. Octode frequency changer. 3.5 watts pentode. Switching for gramophone pick-up. Wave ranges: 16.5-50, 200-550, 800-2,000 metres.

"De Luxe" Model
MCCARTHY ALL-WAVE SIX

with
radio frequency
stage

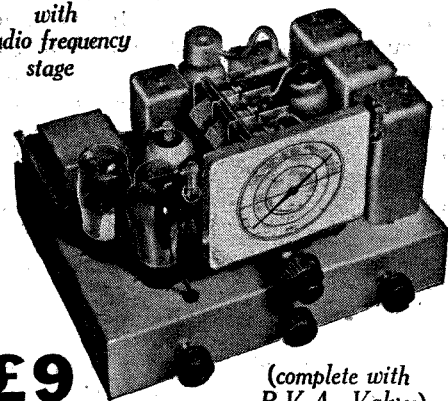

£9 (complete with B.V.A. Valves)

"De luxe" 6 valve receiver with 8 valve performance (specially recommended for tropical and foreign reception conditions). Built on special cadmium-plated 16 gauge steel chassis. Varley iron-cored I.F. coils. Litz-wound tuning coils. 3 wave-ranges—16.5-2000 metres. Illuminated "Airplane" dial with principal station names. Micro-vernier 2-speed drive.

Circuit comprises: Pre-selector radio frequency amplifier (operative on all wavebands), triode-hexode frequency changer, double band-pass coupled I.F. amplifier, double diode-triode detector. D.A.V.C. applied to 3 preceding valves. L.F. amplifier and pentode output. Variable tone control and volume control operate on radio and gramophone.

All McCarthy receivers supplied complete with valves, knobs, pilot lamps, leads, mains cable and plug. 12 months' guarantee.

Deferred terms on application, or through London Radio Supply Co., 11, Oat Lane, E.C.2.

Cash with order on 7 days' approval. Also write for illustrated catalogue of complete range of all McCarthy receivers.

MCCARTHY RADIO LTD.
44a, Westbourne Grove, London, W.2

Telephone: Bayswater 3201/2.

BROADCAST BREVITIES

NEWS FROM PORTLAND PLACE

Christmas at "B.H."

THE programme staff at Broadcasting House have drawn up their plans for Christmas Day and listeners have been told most of the details; but another very active side of the broadcasting machine from which a special effort is required on this day of days has not received the notice that is due to it.

Amid all the restless preparations of programme material, the Catering Staff are getting ready to provide throughout the day and night for a staff who look forward to their Christmas dinner at "B.H."

Turkey and Stuffing

Every member of the staff on duty, every artist whose work takes him to the microphone, has a free Christmas dinner awaiting him. From 8 a.m. onwards on December 25th the kitchen staff will be trussing and

at Maida Vale and Alexandra Palace.

Televised Operas

ALTHOUGH the television programmes at Christmas reach a peak value, it does not appear that there will be any great falling off of interest after the holiday season. Early in the New Year the first regular presentation of opera will begin in the Alexandra Palace studios.

The first operatic programme will, it is understood, comprise excerpts from "I Pagliacci" by the Vic-Wells Company, with costumes and scenery. The Television Orchestra will be in support.

Telev viewers may also expect a number of one-act plays. There are many "curtain-raisers" which should be ideal for television purposes, as their normal playing time is from 20 to 30 minutes.

markable as the total membership of the Orchestra is only 22.

The new miniature dance band—Eric Wild and his Tea-Timers—will be featured for the first time in the television programmes to-day (Friday).

Tributes from the Great

Actually, Mr. Hyam Greenbaum has formed one of the best orchestras—certainly the most versatile—now playing under the aegis of the B.B.C. This fact is readily conceded by distinguished conductors who have already visited Alexandra Palace.

When it was suggested that this very small orchestra should accompany the recently televised excerpts from "Mr. Pickwick," the "people who knew" hinted that Albert Coates, the composer, would demand a full orchestra or none at all. To everybody's surprise and delight, Mr. Coates, having heard it, declared that the Television Orchestra "would do splendidly," and he conducted it himself.

The Orchestra reached its top note in versatility one afternoon last week. First, under the baton of William Walton, the composer, it accompanied the

is much less prevalent. In fact, a smaller proportion of listeners' licence money is now going to pay B.B.C. employees on the sick list.

Every Thursday the Corporation's medical adviser attends at headquarters to inoculate against colds any member of the B.B.C. staff who hankers after a clean bill of health. Nor does this solicitous care stop at that. If the volunteer for inoculation does not "take" with the use of stock vaccine, he is sent to one of the large hospitals for autogenous vaccines. Gargles and throat lozenges are also available for those who require them, and a matron is in daily attendance to administer homeopathic doses to all and sundry.

Do Not Touch

THE close proximity of the Alexandra Palace sound and vision aerials, which carry very high voltages, makes it an impossible task to carry out a repair to one whilst the other continues to operate. This difficulty arose on Monday last when the aerial system was damaged in the gale, and an announcement concerning the non-radiation of the television programme was given on the normal broadcast wavelength.

Television Signal Strength

THE B.B.C. engineers are discreetly silent on the subject of ultra-short-wave field strength measurements in the

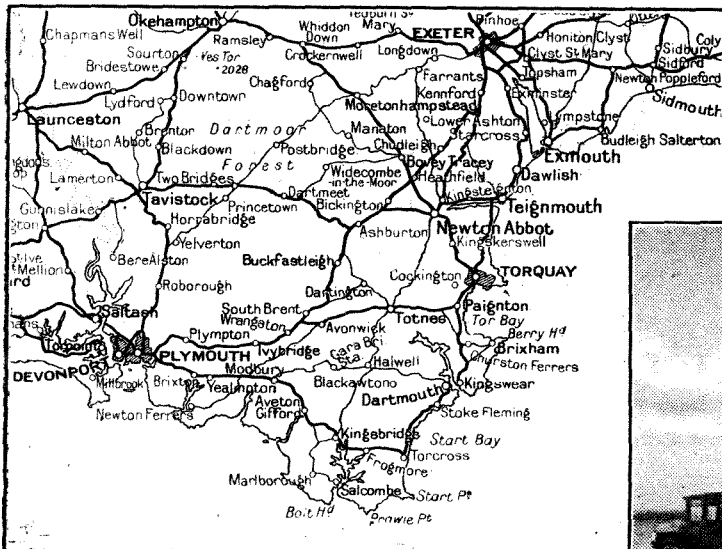

SOUTH-WEST REGIONAL.—As exclusively stated on this page three weeks ago the site for the new station has been decided. It is to be near Start Point, almost the most southerly position to be seen on the accompanying map. One of the B.B.C. vans, specially equipped for testing sites, is seen during a visit to the selected areas.

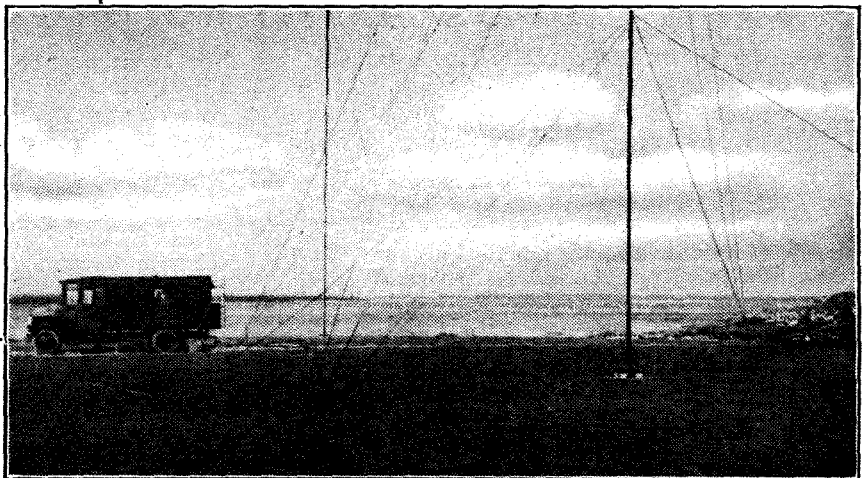

dressng turkeys in readiness for the mid-day meal.

This meal will include all the traditional Christmas dishes, and the catering staff, having cleared away the remains, will start preparing just as elaborately for the afternoon, the evening, and right on until 7 o'clock in the morning of Boxing Day; for the Empire staff and broadcasters must be provided for with the same generosity, as also must the people

Real Versatility

IF the B.B.C. Symphony Orchestra were to form a rhythm section from existing personnel the musical world would gape. Riots would probably ensue and questions might be asked in the House. Yet nothing of the kind has followed the formation of a rhythm section by members of the Television Orchestra, although the achievement is the more re-

Vic-Wells Ballet Company in "Facade"; then, with scarcely a break, it played for Sophie Tucker in her famous "red hot momma" songs.

The B.B.C.'s Dispensary

CASUALTIES due to influenza have bulked largely at Broadcasting House in past winters, but since the recent introduction of free inoculations, the tendency to catch cold

London area. It is true that polar diagrams exist, but the very high frequencies are behaving in such an inconsequential manner that no map which failed to give average signal strength over quite a long period could possibly be regarded as up-to-date for any length of time.

To publish a signal strength map on inadequate data might be damaging to the cause of television.

Wide Range Record Reproduction

DETAILS OF A NEW AMERICAN MAGNETIC PICK-UP

UNTIL quite recently a pick-up with a response up to 5,000 cycles was adequate for the best class of records, but with modern improvements in recording it will not be long before the demand for a level response up to at least 8,000 cycles will become general.

The chief obstacle to the extension up-

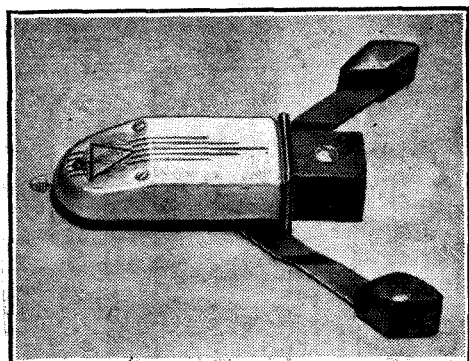

In the new "Audak" pick-up the needle is inserted from above.

wards of the frequency range of a pick-up is the mass of the vibrating armature system. This consideration led to the development in this country of the needle armature pick-up in which the mass was reduced to the absolute minimum, namely, that of the needle itself. Unfortunately, the efficiency of pick-ups of this type is comparatively low, as the steels which are the best from the point of view of needle wear do not exhibit correspondingly good magnetic properties; and hardwearing properties come first, as it is useless to achieve a good high-frequency response if the "flat" worn on the needle becomes comparable with the wavelength of the highest notes before the inside grooves of the record are reached.

The new "Audak" pick-up now in production in America appears to offer a solution of this problem, for the fundamental resonance of the vibrating system has been kept above 8,000 cycles, while at the same time the needle has been taken outside the magnetic circuit.

The principle of operation is shown diagrammatically in Fig. 1. The "armature" is in two sections. The main section with coil wound thereon is stationary, and is insulated magnetically from the pole shoes by two very small gaps. There is a third gap which is formed by the two pole shoes and the main armature. This gap is circular, and in it rotates the second part of the armature—the moving portion known as the "exciter." This exciter is of very small dimensions, and it changes the magnetic reluctance of the armature path by varying the size of the "control

air gap." This acts in much the same manner as a relay, generating a much larger voltage across the coil than could be expected from a conventional moving armature and magnetic circuit. The principle is, in fact, not unlike that of the Wheatstone bridge.

The exciter is attached to a duralumin needle-holder, and its moment of inertia is very small. Furthermore, the movement required to produce a given voltage is little more than 1-20th that of the conventional type of armature. Actually the amplitude at the tip of the exciter is less than that of needle-point.

With the balanced magnetic circuit little restoring force need be supplied to keep the vibrating armature centralised, and as a consequence of this the needle will

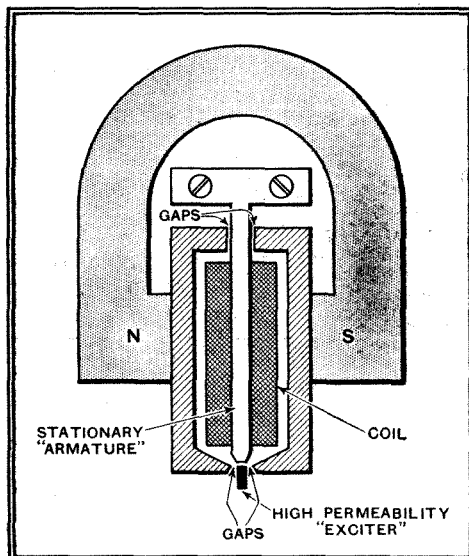

Fig. 1. Schematic section showing principle of the balanced magnetic circuit in the Audak pick-up.

follow the groove properly with a pressure of only 1½oz. instead of the usual 5oz. Counterbalance weights have been fitted to adjust the pressure correctly, and the record wear is correspondingly reduced.

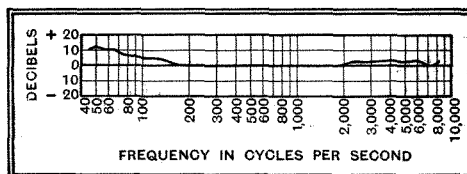
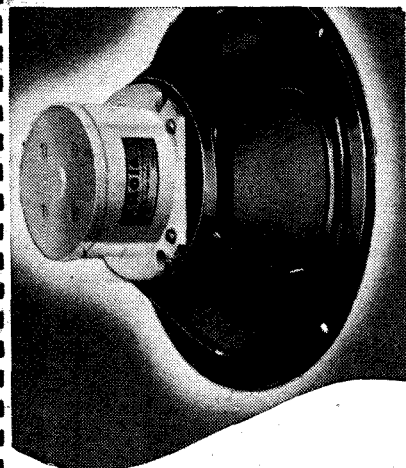

Fig. 2. Frequency response curve of the Audak pick-up.

The response curve is reproduced in Fig. 2, and it will be seen that it compares favourably with other components, such as microphones, in the chain of high-quality reproducing equipment.

POINTS OF IMPORTANCE in the Rola G.12



AS SAFE AS THE BANK

The Bank of England has always been a symbol of financial reliability. In the same way the presence of a Rola G.12 speaker in a radio receiver is proof of the reliability of the whole set. It shows clearly the fact that in choosing his components the manufacturer has examined all possibilities and stopped short at the best. Manufacturers have found this season that it is G.12 equipped sets that show the biggest sales increase. Listeners have found that no other speaker gives them such perfect reproduction. In whichever category you come it will pay you to see that your set is G.12 equipped.

G.12 P.M. (as illustrated) less Transformer	£4 16 0
G.12 P.M. with Transformer	£5 5 0
G.12 D.C. Complete with Transformer, Mounting Stand, Handle and Base	£5 5 0
G.12 D.C. with Mounting Stand, Handle and Base, but without Transformer	£4 16 0
G.12 D.C. Stripped, but with Transformer	£4 4 0
G.12 D.C. Stripped and without Transformer	£3 15 0

(When ordering please state Field Resistance and Impedance of Transformer required.)

For Public Address work both the P.M. and Energised Models can be supplied with a 15 ohm Voice Coil at an additional charge of 3/-.

Write for Folder A.

OVER 7 MILLION IN USE

ROLA

The World's Finest Reproducers

THE BRITISH ROLA CO., LTD.
MINERVA ROAD, PARK ROYAL, N.W.10.
PHONE: WILLESDEN 4322-3-4-5-6.

Recent Inventions

The British abstracts published here are prepared with the permission of the Controller of H.M. Stationery Office, from Specifications obtainable at the Patent Office, 25, Southampton Buildings, London, W.C.2, price 1/- each. A selection of patents issued in U.S.A. is also included.

Brief Descriptions of the more interesting radio devices and improvements issued as patents will be included in this section

ELECTRON "GUNS"

THE invention relates to the electrode arrangement of the "gun" part of a cathode-ray tube, or to the jet producing electrodes of a valve amplifier of the so-called beam type. In both cases undesired effects are liable to be produced (a) by stray electrostatic fields from the Wehnelt cylinder, and (b) by the return to the "gun" of secondary electrons produced by the impact of the stream on the collecting anode.

As shown in the figure the cathode K is located inside a con-

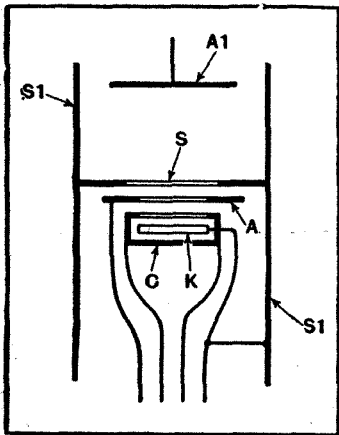

Arrangement of the electrodes in the cathode-ray tube described in Patent No. 454258.

control electrode C which is provided with a central slit running parallel with the cathode, in order to pass the stream through to an accelerator anode A. Between the latter and the main or collecting anode A1 is a screening disc S, which is welded to the walls of a cylinder S1 which extends downwards below the foot of the cathode (to which it may be connected) and upwards beyond the anode A1.

PIEZO-ELECTRIC CRYSTAL

TO stabilize its frequency a piezo-electric oscillator is enclosed in a hermetically-sealed container, which is safeguarded from temperature-variations by thermostatic control. The vessel is also filled with hydrogen gas at a pressure of over half an atmosphere.

One advantage of the arrangement is that hydrogen damps the crystal less, for a given pressure, than does ordinary air, and hence a higher pressure of hydrogen can be used than of air. This in turn allows a more uniform temperature to be maintained since the greater mass of gas gives more facility for the transfer of heat by convection. Another advantage is that hydrogen is (for a gas) a relatively good conductor of heat, which further assists in maintaining the crystal at a uniform temperature.

Marconi's Wireless Telegraph Co., Ltd., and G. F. Brett. Application date March 11th, 1935. No. 453500.

TELEVISION RECEIVERS

IN a combined sound-and-television receiver, the sound programme is handled by a super-regenerative pair of push-pull valves, V, V1, and the "quenching" frequency required to make them function in the required manner is derived from the usual scanning voltages applied to the deflecting plates of the cathode-ray television receiver.

Signals from the aerial are applied to the input of the valves V1, V2 through a coil L, which is back-coupled to the anode coil L1 in the regenerative sense and to the anode coil L2 in a degenerative sense. The time-base circuit supplying scanning-potentials to the deflecting plates P of the cathode-ray tube, as shown diagrammatically at S, is connected across a

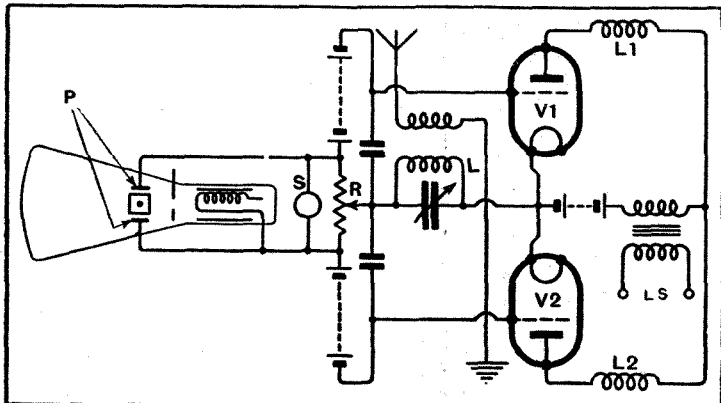

Method of utilising the scanning voltages for quenching in the sound portion of a television receiver.

This arrangement prevents both the undesirable features mentioned. Marconi's Wireless Telegraph Co., Ltd., G. M. Wright, and G. F. Brett. Application date March 27th, 1935. No. 454758.

resistance R, so as to supply "quenching" oscillations to the amplifier V, V1 which feeds the loud speaker LS. The arrangement is such that the "quenching" period coincides with the "fly-

back" period of the scanning-spot across the fluorescent screen of the television receiver. The relative duration of "quench" can be adjusted by shifting the point at which the cathodes are connected to the resistance R.

Marconi's Wireless Telegraph Co., Ltd.; and A. A. Linsell. Application date March 4th, 1935. No. 453135.

o o o o

MODULATING SYSTEMS

IN a broadcast or other transmitter the carrier-wave is arranged to "float" in amplitude, in sympathy with the strength of the modulating signal, in order to economise the total expenditure of power. As shown in the figure,

the push-pull amplifiers diminishes, and the effective HT voltage across PA becomes higher, with the result that the carrier-wave output keeps step with the strength of the applied signals. Modulation is due to the inclusion of the secondary coil S in series with the high-tension supply.

British Thomson-Houston Co., Ltd. Convention date (U.S.A.) October 4th, 1934. No. 453732.

o o o o

TUNING DEVICES

IT is known that a two-wire transmission line a quarter-wave long can be used as a resonant coupling or tuning element, particularly in short-wave working. It has also been discovered

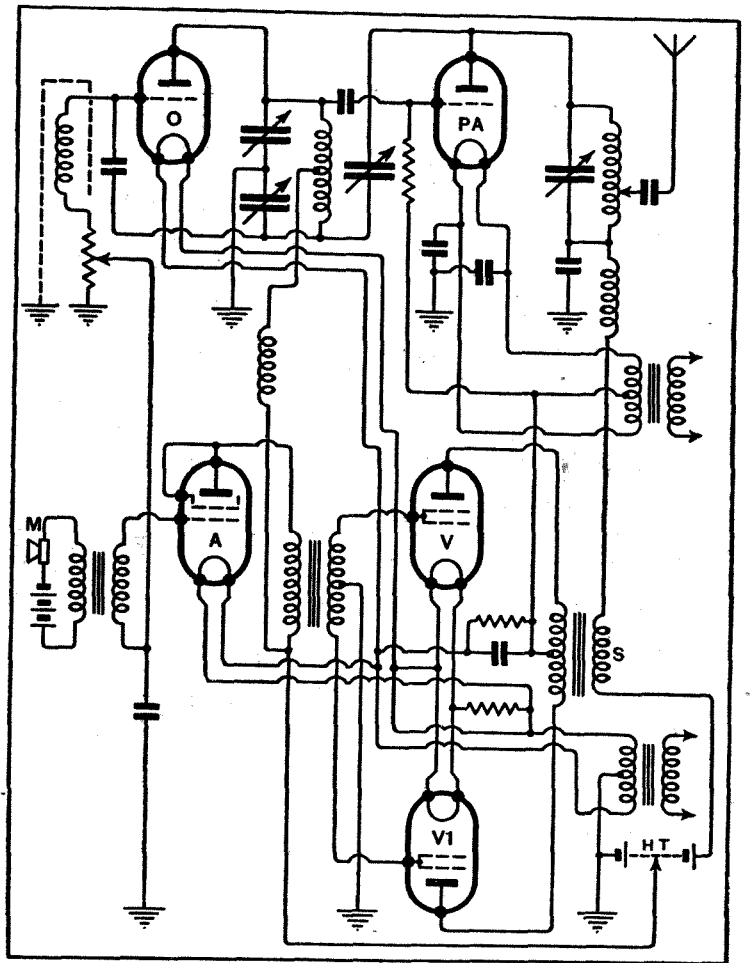

Circuit for carrier-wave modulation.

the microphone signals are applied from M through an amplifier A to a pair of Class-B amplifiers V, V1. Meanwhile the carrier frequency is generated at O and passed to a power amplifier PA. The amplifier A and the class-B pair V, V1 are all arranged in series across a common source of high tension HT.

So long as no microphone voltage is applied to the grids of the amplifiers V, V1, their internal resistance is high, and only a fraction of the total HT volts is effective across the amplifier PA, so that the carrier output from that valve is comparatively low. As the LF modulating voltage increases, the internal resistance of

that with a coaxial two-conductor line of this kind, when the centre wire is shorted to the outer tube or conductor at one end, the tuning of the quarter-wave resonator so formed can be varied within limits by displacing the inner conductor so as to make it eccentric with the outer tube.

The invention consists in so mounting the centre wire inside the tube that it can be moved to one side or other of the centre line, by rotating a cam-shaped end-block, thereby varying the tuning of the element as a whole. Standard Telephones and Cables, Ltd. Convention date (U.S.A.) May 17th, 1935. No. 451077.

The Wireless World

THE PRACTICAL RADIO JOURNAL
26th Year of Publication

No. 904.

FRIDAY, DECEMBER 25TH, 1936.

VOL. XXXIX.

No. 26.

Proprietors : ILIFFE & SONS LTD.

Editor :
HUGH S. POCOCK.

Editorial,
Advertising and Publishing Offices :
DORSET HOUSE, STAMFORD STREET,
LONDON, S.E.1.

Telephone: Waterloo 3333 (50 lines).
Telegrams: "Ethaworld, Sedist, London."

COVENTRY: Hertford Street.

Telegrams: "Autocar, Coventry." Telephone: 5210 Coventry.

BIRMINGHAM:

Guildhall Buildings, Navigation Street, 2.
Telegrams: "Autopress, Birmingham." Telephone: 2971 Midland (4 lines).

MANCHESTER: 260, Deansgate, 3.

Telegrams: "Iliffe, Manchester." Telephone: Blackfriars 4412 (4 lines).

GLASGOW: 26B, Renfield Street, C.2.

Telegrams: "Iliffe, Glasgow." Telephone: Central 4857.

PUBLISHED WEEKLY. ENTERED AS SECOND CLASS MATTER AT NEW YORK, N.Y.

Subscription Rates :

Home, £1 1s. 8d. ; Canada, £1 1s. 8d. ; other countries, £1 3s. 10d. per annum.

As many of the circuits and apparatus described in these pages are covered by patents, readers are advised, before making use of them, to satisfy themselves that they would not be infringing patents.

CONTENTS

	Page
Editorial Comment	661
The Year's Progress	662
Improving the Super-regenerative Set	665
Unbiased	668
Further Notes on Negative Feedback Amplification	669
Current Topics	671
Broadcast Brevities	672
New Apparatus Reviewed	673
Hylvoltstar "Battery-Mains" Receiver	674
Listeners' Guide for the Week	676
Letters to the Editor	678
The Pentode Tone Corrector	679
Random Radiations	680
Resistance-Coupled Amplifiers VI	682
Recent Inventions	684

EDITORIAL COMMENT

Service

Not a Synonym for Trouble

THE fact that a wireless receiver is so intricate a piece of apparatus, incorporating mechanical as well as electrical components always liable to develop defects, makes it fairly certain that however well a receiver is designed and however carefully constructed and tested by the manufacturer, there must always remain a possibility, and indeed a probability, that from time to time some attention will be necessary by way of maintenance and service. If we accept, then, that a wireless set, just like a motor car, will require occasional attention after purchase, the next point for consideration is how this problem of service should be tackled in the case of wireless sets.

The subject is one which has demanded the attention of manufacturers and dealers ever since broadcasting began, and even to-day no uniform method of dealing with the matter has been adopted.

Much of the trouble seems to arise from the fact that the public has not had the question of service put to them on a satisfactory basis. The guarantee given with a new motor car normally covers the replacement of parts which, during the period of the guarantee, are found to develop defects, but ordinary wear and necessary adjustments are the responsibility of the owner, and either he attends to these himself or pays for the work to be done at a service station or garage. If the same attitude towards wireless sets were adopted, it would clear up much of the present misunderstanding.

We do not wish to make excuses for the manufacturer who sends out his receivers carelessly constructed and improperly tested, but we believe that

manufacturers whose sets give undue service trouble will not survive, so that carelessness of this kind will find its own remedy. We would, however, like to see a clear statement from manufacturers as to just what their guarantee is intended to cover, and for the guarantee to be uniform. The facts should then be made clear to the purchaser, so that where ordinary servicing to his set is required he accepts it and the charges for it with the same good grace that he would in the case of his car.

Dealers in all parts of the country should take the question of service seriously, putting it upon a business footing and equipping themselves with the necessary apparatus and staff to ensure that they are competent to carry out the work to the satisfaction of their customers. To expect a completely trouble-free wireless receiver would be to ask an impossibility. If we accept, as we must, that service is an essential part of the radio industry, let it be tackled effectively and with a proper spirit, shown both on the side of the dealer and the customer.

New B.B.C. Governors

A Happy Selection

THE choice of Sir Ian Fraser, M.P. for St. Pancras North, and Dr. J. J. Mallon, of Toynbee Hall, as governors of the B.B.C., is a matter for very general satisfaction.

Sir Ian Fraser is particularly well known to our readers because of his long association with wireless and broadcasting interests.

His decision to retire from the House of Commons will be regretted, but the reasons which he has given for this decision are consistent with the high ideals of public service which have always characterised his actions.

The Year's Progress

DEVELOPMENTS IN WIRELESS COMMUNICATION

By LT.-COL. CHETWODE
CRAWLEY, M.I.E.E.

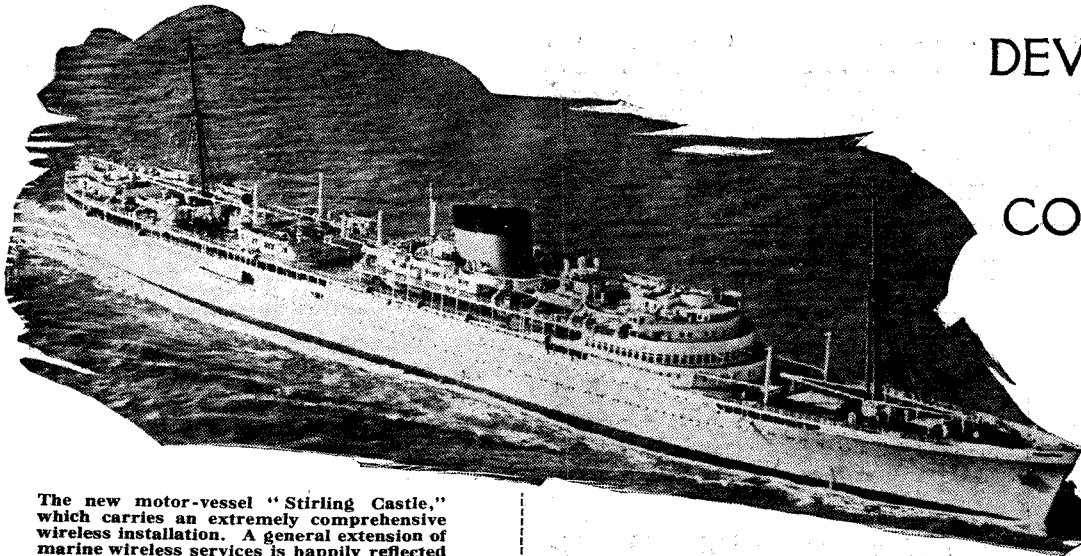

The new motor-vessel "Stirling Castle," which carries an extremely comprehensive wireless installation. A general extension of marine wireless services is happily reflected in increased safety of life at sea.

THE long-range telephone services continued to grow during the year, but at a much less hectic rate than was the case a few years ago when the field for expansion was almost clear. The reduction of rates, however, was a marked feature.

At the beginning of the year, Brazzaville, in French Equatorial Africa, was connected to the Brussels-Belgian Congo service, and San Domingo and Honduras were brought into the London-New York radio-telephone circuit. In February, there was an interesting ceremony conducted through the medium of this transatlantic circuit when Sir William Bragg, by lighting a candle at the Royal Institution in London, released electrical energy which was used for the opening ceremony of the Museum of Science and Industry in New York, the speeches in London and New York being broadcast throughout the United States. In March, a service was opened between this country and Kenya, Uganda and Tanganyika at a rate of £4 10s. for three minutes' conversation, and in July this circuit was extended to various towns in Kenya. In April, the England-Cairo service was extended by landline to Baghdad. In May, a service was opened between the Orkney and Shetland Islands, and also with Guernsey on a five-metre wavelength, this latter being the highest power ultra-short-wave commercial telephone link in the world.

In June, reduced rates for Saturdays were introduced on the Egyptian and Argentine circuits, and in July, important reductions in rates were made for the transatlantic service with the United States and Canada. In this service the rate for the three-minute call between this country and the first zone overseas (including New York and Montreal) was reduced from £6 to £4 4s., between 10 a.m. and 10 p.m., and from £4 4s. to £3 between 10 p.m. and 10 a.m., these reduced night rates being applicable throughout Sundays. Corresponding re-

IN this, the last issue of the old year, we follow our usual practice by publishing an authoritative article on non-broadcasting wireless developments of the past 12 months. Extensions of the long-distance radio-telephone and telegraph services are recorded, while increasing use is being made of ultra-short waves for communication at short ranges.

ductions were made for the other zones, and the rate for Cuba and Mexico was reduced from £7 16s. to £6, but with no further reduction at night. In August, the £6 rate to Japan was reduced for Saturdays to £3.

In August, too, the first zone in the telephone service with Atlantic liners was extended in a westerly direction from longitude 18 degrees west to longitude 35 degrees west. The lower rate of £1 16s. for three minutes was thus extended from 500 miles west of Land's End to about half-way across the Atlantic. Beyond this distance a double rate of £3 12s. is charged. In November, the rate for calls *via* New York, when direct calls to the ship are subject to delay, was reduced from £7 4s. to £5 8s.

In October, a service was opened to all parts of Porto Rico at £4 16s., and at the same time substantial reductions were made in the rates to the Bahamas, Columbia, Costa Rica, Dominica, Guatemala, Hawaii, Honduras, Nicaragua and Panama.

In November, for the first time, an exchange of speeches was conducted be-

tween a ship at sea and a public gathering in London. On this occasion a luncheon was being given to honour Sir George Brown, who was retiring from the European general managership of the Canadian Pacific Railway. Speeches at the luncheon were heard in the C.P.R. liner "Empress of Britain," which was on the outward voyage, 1,200 miles from England, and speeches made aboard the

liner were heard by those assembled at the luncheon in London.

On the telegraph side no new services were established directly with this country. Abroad, duplicate circuits were established in March between New York and Rio de Janeiro, Haiti and Prague, and a new circuit opened with San Salvador. In April, services were opened between Bangkok, Sierra Leone and Vienna, on the one hand, and Saigon, Mon-

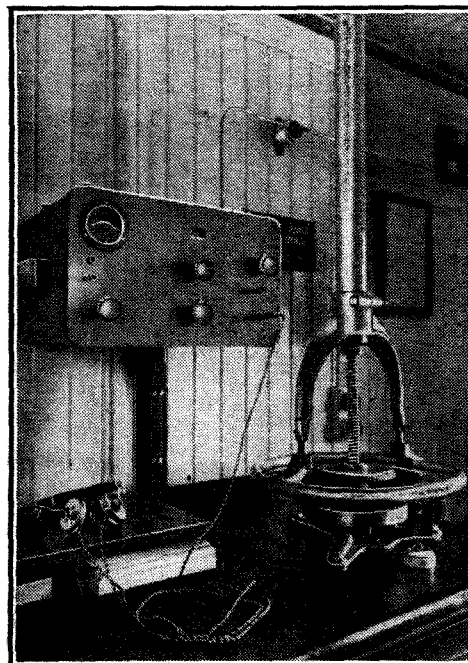

Siemens' direction-finding apparatus installed on board the M.V. "Imperial Star."

rovia and Oslo on the other. In May, Tokio and Vienna were connected with Oslo and Riga respectively, and, in June,

The Year's Progress—

Tokio, Rome and Aden with Tientsin, Addis Ababa and Makalla. In July, a circuit was opened between Tokio and Moscow, and in September between Beyrouth and Djibouti.

All direct wireless telegraph services with Ethiopia were closed on May 4th, and there are now only two circuits, one between Addis Ababa and Rome and the other between Addis Ababa and Asmara, both of which are conducted by the Italian Government.

In June, the Radio Corporation of America gave a very interesting demonstration of facsimile transmission on ultra-short waves of about 3 metres between New York and Philadelphia. The total distance was 90 miles, and there were two intermediate relay stations at visual distances. These intermediate stations were switched on and off automatically by a tone signal from

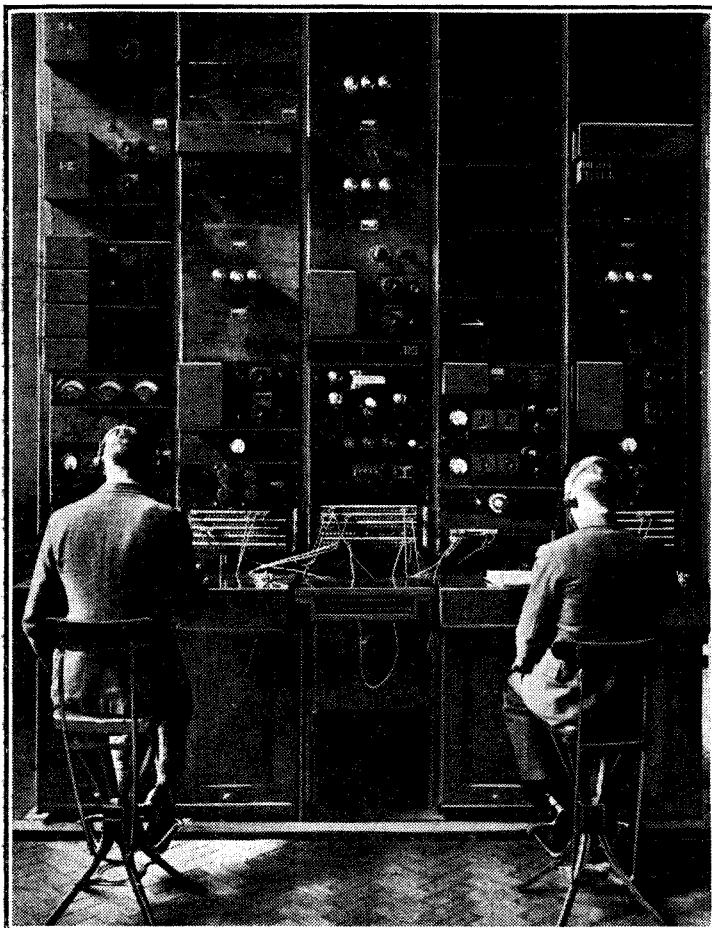

The Overseas Radio-telephone Exchange, Faraday House, London. This photograph shows technical operators at work on the Australian and New York circuits.

either terminal station. Six waves were used for the complete circuit, and were scrambled for secrecy. It was said that this demonstration showed such great possibilities for multiple transmission that wireless in the future might not only steal land line traffic, but might even dip into the mail bags.

The increased activity in shipping was reflected in the year's progress of the ship-to-shore wireless services. It is interesting to note that there are now about 15,000 ships fitted with wireless throughout the world as compared with about 14,000 five years ago. Of these, over 8,000 are still equipped with spark installations, the remainder having valve sets; arc transmitters have now passed away altogether.

The number of ships fitted with direction-finding apparatus has nearly doubled in the last five years, and is now well over 5,000. There is also a rapidly increasing number of small craft fitted with low-power telephone equipment suitable for communication up to a range of about 150 miles. It is interesting, too, to see how this fitting of vessels with wireless has affected the safety of the ships and the men they carry, and in this connection the

Chamber of Shipping has issued some informative figures. From these it appears that our shipping is now two and a half times safer than before the War, and foreign shipping nearly twice as safe. Of

the world's tonnage we own a third, but of the world's losses we suffer only a quarter. As regards crews, the loss for the four years before the war was 1 in 582 (or, if the "Titanic" and "Empress of India," which were exceptional losses, were omitted, 1 in 412), whereas in the period 1932-34 the losses were only 1 in 2,360, indicating that the losses are now about 4 to 6 times less than before the War. As regards passengers, for every 19 lost in the period 1910-14, only 1 was lost in the period 1929-33.

At the beginning of the year wireless was concerned in a dramatic episode of life-saving in the Antarctic. The American ex-

Receiving points at the P.O. Land's End station, which communicates with ships. The transmitting gear is seen in the background.

plorer, Mr. Ellsworth, and the Canadian airman, Mr. Kenyon, who had set out on exploration work near the South Pole, had

been missing since November 23rd, and on January 2nd "Discovery II" sailed from New Zealand in search of them, keeping in touch with civilisation by short-wave communication with Portishead Radio in England. The progress of the search was followed keenly throughout the world from the messages sent direct from the ship to Portishead across 10,000 miles of space, eventually culminating in the message, "Both alive and well," on January 17th.

"Greetings" at Sea

On April 1st the special inland telegraph service of "Greetings" telegrams was extended to radiotelegrams from ships at sea, the radios being copied on to the special greetings form at delivery offices and delivered to the addresses in the special envelope. The extra charge for this service is the cost of the indicator word, "Greeting."

On July 1st important reductions in ship-to-shore rates were introduced in this country. The old standard charge of 11d. a word for the ordinary full-rate plain language message had been in force here, and in most other countries, since the early days of ship-to-shore communications, and it had been felt for some time that, although there were lower charges for short-voyage ships, for tourist traffic and for ship letter telegrams some suitable time should be chosen for the reduction of the standard rate and the readjustment of others.

Ships' traffic, which had suffered in the slump years, was showing an encouraging upward trend, and for this, amongst other reasons, it was decided to reduce and readjust rates this year. Accordingly the standard rate was reduced from 11d. to 8d., which covers direct transmission to, or reception from, suitably equipped ships in all parts of the world, via Portishead Radio. The rate for messages sent from

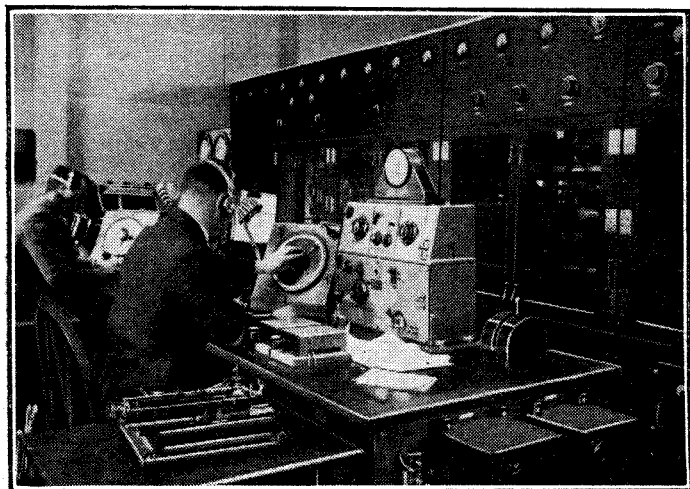

the high-power station at Rugby was reduced, too, from 1s. 6d. to 1s. a word. This service meets the need of ships in distant waters which can receive Rugby's transmissions, but are not themselves fitted with short-wave equipment which would allow of communication with

The Year's Progress—

Portishead. The rate of 4d. a word for short-voyage ships was not altered, but was made available to all ships regularly engaged on voyages of not more than 1,000 miles from a port in the British Isles, instead of being limited to those on voyages up to 200 miles.

An interesting monthly communication was conducted during part of the year by Portishead Radio with the Oxford University Arctic Expedition in North East Land. It was a land of evil reputation, as all previous expeditions, including that of Nobile during 1928, had met with disasters of one sort or another. This Oxford Expedition, led by Mr. A. R. Glen, was the first to winter there, and obtained a mass of very useful information, including, from the wireless point of view, data on signalling conditions in the ionosphere, collected for the first time from a position north of the auroral belt.

In June, the "Queen Mary's" maiden voyage to New York produced a record in wireless traffic for the trip which will take some beating. The total telegraph traffic handled on board amounted to nearly 132,000 words, of which Portishead Radio alone dealt with about 50,000, and the telephone traffic to 149 calls, totalling 826 minutes. In addition, 40 broadcast programmes were sent from the ship to America, England, France, Denmark and Holland, occupying 647 minutes.

The equipment in the "Queen Mary" has already been fully described in this journal,* and it will be remembered that it consists of four large transmitting plants, eight receivers and a self-contained emergency set, as well as a DF installation and equipment for two life-boats.

During the year there has been a considerable addition to the number of small ships, mostly fishing craft, fitted with wireless telegraphy and telephony, and the traffic of these vessels with the shore is increasing satisfactorily. More than half this traffic is carried out with Wick Radio in the north of Scotland, and arrangements have now been made to increase the capacity of that station by placing the receiving aerials at about a mile from the station, thus allowing of the simultaneous working of more than one channel.

All the coast stations are equipped with telephony for this communication with small craft, and for the last couple of years the telephony set in the coast station at Seaforth, near Liverpool, has been linked up experimentally to the land lines, so that communication could be carried out direct between the ships and subscribers on shore. It was considered that the same facility should be provided from an East Coast station, so a similar link service is being opened at Humber Radio.

Some interesting experiments in sending facsimile weather maps to Atlantic liners have been carried out during the year by the Radiomarine Corporation of America, in co-operation with the U.S. Weather Bureau. The weather map measures

8 inches by 10 inches, and takes 20 minutes to receive. Maps have been received from America in European waters on a frequency of 13 kc/s, 6 kc/s being used for shorter ranges.

In the case of air communications, every aircraft used for international public transport and capable of carrying ten or more persons must be equipped with wireless, and all of those of 2,000 kg. or over must be so equipped if on a day flight of more than 160 kms., or over 25 kms. across sea, or for night flying.

There are now over a dozen stations in this country for civil aviation, and it is indeed common practice for aerodromes to have short-range stations for close control. It has not yet been found necessary to arrange for commercial traffic direct between aircraft and ground stations in this country, but service traffic is rapidly increasing owing to the expansion of internal air services. The bulk of this traffic consists of route traffic and meteorological messages, and the rest of messages in connection with navigation. At the beginning of the year a modified medium-wave radio beacon was brought into service at Croydon to provide approach guidance for aircraft not equipped with the special receivers required for the ultra-short wave system, and a great deal of work has been done on blind landing systems.

These arrangements provide for guiding the aircraft to its landing place after it has been brought by ordinary DF to within about twenty miles of the aerodrome. From that distance the pilot is led in by a system of two 9-metre beams from a station in the aerodrome. One beam sends out a series of dots on one side of the true course, the other beam a series of dashes on the other side of the true course. When the aircraft is on this true course the beam signals merge together, so that the pilot hears a continuous dash in his telephones; he is provided as well with a visual indication. The distance from the aerodrome is found by means of marker beacons. The first marker beacon is about three miles from and the second one on the edge of the aerodrome. These beacons send out a vertical sheet of wireless radiation at right angles to the path of approach, and when the aircraft passes through the sheet of radiation a receiver is actuated and an indicating lamp is lit in the aircraft.

Much work, of course, has been carried out during the year in connection with the Empire air routes; for instance, over a score of stations have now been arranged for the England-South Africa route so that the flying boats may be in constant touch with the ground throughout the entire journey.

International Radio Vocabulary

Important Work in Preparation

THE International Electro-Technical Commission has issued an advance announcement regarding the forthcoming publication of the first edition of the International Electro-Technical Vocabulary, which is due to appear next year. This event marks the culmination of many years' work by delegates from all parts of the world.

Definitions are to be given in both English and French (the official languages of the I.E.C.), while a translation of the *terms* only will appear in German, Italian, Spanish and Esperanto.

Some at least of the language difficulties encountered in drafting internationally acceptable definitions in both English and French have been surmounted by the action of the British and American Committees, who agreed that the definitions should in the first place be drafted in French.

This first edition of the Vocabulary represents an attempt towards the unification of electrical nomenclature, and although only

one of its 14 sections (that headed Radio-communication) deals exclusively with our subject, it will probably be accorded at least as warm a welcome in wireless circles as in other branches of electrical engineering.

The price of the Vocabulary has been tentatively fixed at approximately 10s., the exact price being dependent on the anticipated demand. Those interested are invited to request the British National Committee of the I.E.C. to reserve a copy or copies on publication; the address is c/o The British Standards Institution, 28, Victoria Street, London, S.W.1.

CATHODE-RAY TUBES IN THE MAKING.—This photograph, taken in the CR section of the Ferranti valve factory, shows different stages in the manufacture of 14-inch cathode ray tubes, which will eventually be used in Ferranti television receivers.

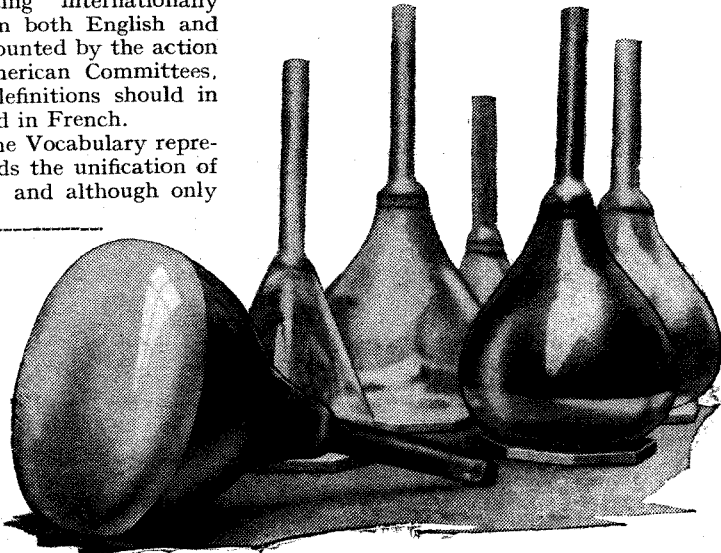

* *The Wireless World*, May 29th, 1936

Improving the Super-regenerative Set

By E. L. GARDINER, B.Sc.

CONVENTIONALLY, pure sine-wave oscillations are used for quenching in super-regenerative receivers. But the author of this article advances the opinion that oscillations of saw-tooth form, giving more rapid quenching combined with a longer building-up period, confer important advantages in several directions. The practical application of the theory is described, and it is shown that the functions of quench generator and wave-form "corrector" may be carried out by a single multiple valve.

THE increasing use to which wavelengths below ten metres are being put is responsible for an ever-growing demand for a simple receiver which will give good results on these wavelengths. Whilst there can be little doubt that the superheterodyne in its specialised form is the best type of receiver for this purpose, considerable skill in design and construction is necessary to obtain high sensitivity and ease of handling, whilst the cost must necessarily be quite high and may not always be considered justified for a receiver for ultra-short wavelengths alone.

The simple regenerative receiver can give quite good results in this region for the reception of telegraphic signals, but lacks sensitivity for the reception of telephony, and is unduly affected by traces of frequency modulation present in most ultra-short wave signals, which gives rise to poor quality or even complete unintelligibility. It also calls for very great care in construction, and adjustment at very high frequencies, and preferably for the use of special valves.

It is therefore not surprising that the super-regenerative receiver remains by far the most widely used type in this field, and seems likely to remain so for many purposes. It has the great advantages of high sensitivity and ease of adjustment, together with simplicity and low cost, it being possible to construct quite an efficient receiver with only a single valve, although two or three are more general; in view of these good properties any further technical improvements which can be added are likely to meet with general approval. In addition, the circuit possesses the valuable properties of a high degree of inherent AVC action and an ability to discriminate against local noise;

attributes too valuable to neglect lightly. Its drawbacks lie in poor selectivity and a tendency to bad quality when the signals received are deeply modulated; the former factor is, however, unimportant as yet, since the wavelengths below ten metres are far from congested, and there is no difficulty, for example, in separating the vision sound programmes from their neighbouring transmissions, while the question of quality has probably been overstressed. The modulation of transmissions on these wavelengths is not usually very deep, and provided that a high quenching frequency is adhered to and ample magnification provided after detection (so that the signal level can be kept low at the detector grid) the quality of reproduction will be adequate for general listening.

The efficiency of the circuit is clearly dependent basically upon that of the super-regenerative process itself. This in turn is brought about through the action of a local oscillator of relatively low frequency upon a more-or-less normal detector stage in which ample reaction is available. The various factors which determine the effectiveness of this quenching oscillation have been the subject of considerable investigation, and are comparatively well known.

Thus, for example, it is found that the amplitude of the quenching oscillation should bear a relation to that of the detec-

tor determined by the degree of regeneration applied to the latter, and this relation is arrived at in practice by controlling the regeneration of the detector or the amplitude of the quenching oscillation, or both, and by suitable circuit design. Details of this factor are outside the scope of the present article, but have an important influence upon the behaviour of the receiver, its signal-to-noise ratio and sweetness of handling.

Again, the choice of the optimum quenching frequency has been the subject of investigation, and it has been established that this should be approximately proportional to that of the incoming signals, being of the order of 0.05 to 0.005 of the signal frequency.

Broadly speaking, it is found that lowering the quenching frequency results in improved sensitivity and increased selectivity, with an increased tendency to

distortion if the incoming signals are heavily modulated or subject to frequency modulation; whereas raising the quenching frequency cleans up this distortion and broadens the selectivity somewhat. At some intermediate value there will be an optimum frequency for any wavelength which results in best sensitivity and cleanest reception, and which is fortunately not critical.

Little if any attention seems to have been given to the third factor which in-

A New Method of Quenching

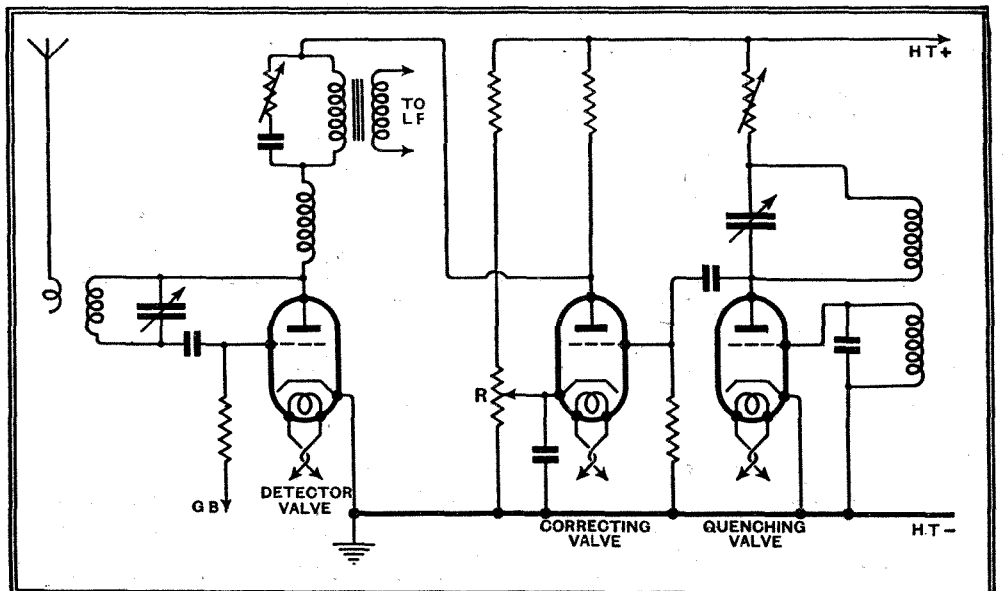

Fig. 1.—Super-regenerative receiver with an extra valve for modifying the wave-form of the quenching oscillations.

Improving the Super-regenerative Set—

fluences the quenching oscillation, namely, its wave-form; the general assumption having been made that this is sinusoidal and unimportant; and the writer therefore thought it desirable to make preliminary investigations into this factor, and to determine if in fact it has any appreciable effect upon the performance of the receiver.

Saw-toothed Quenching Waves

Considerations of the simple theory of super-regeneration would seem to suggest that a decided improvement should result from a departure from the sinusoidal quenching oscillation. The operation of the detector stage is regarded as consisting of alternate periods each of about the duration of one half-cycle of the quenching oscillation, although not exactly in phase with this. During one of these periods in which the bias of the detector is favourable for regeneration the detector builds up towards a state of self-oscillation and signals experience a considerable amplification as a result of this intensive regeneration. At about the time when a state of continuous oscillation is reached (the exact period depending upon the adjustment of the relative amplitudes) the reversal in polarity of the potential applied to the detector grid by the quenching oscillation occurs, and the bias becomes unfavourable to regeneration with a consequent damping out of the oscillations. The process is then ready to repeat itself with the next cycle of the quenching oscillation.

It can thus be seen that the most efficient operating condition might be expected to occur when the period of damping is as brief as possible and the damping bias very great, thus minimising the time spent in this inactive state during which no signal amplification occurs, whilst at the same time the regenerative periods should be as intensive as possible, and increased in duration to compensate for the reduced duration of the damping periods. In the case of a sinusoidal quenching oscillation the two periods just referred to may be expected to be similar in duration, corresponding approximately with the half-cycles of the oscillation. Moreover, the conditions for regeneration or quenching will not be fully effective throughout each half-cycle, since the bias is only at a maximum for an instant at the peak of each of these, and is rising or falling during most of the time. Better efficiency might be expected if a complete instantaneous reversal of the quenching potential could be obtained, the wave-form being thus rectangular instead of sinusoidal; but since this is very difficult

to obtain electrically a saw-tooth wave-form of the type employed in cathode-ray time base circuits was considered the next best to adopt, the phase of this being such that the sudden sharp peak of the tooth

indicated a noticeable improvement in performance, and hence it was thought worth while to try out a more practicable arrangement, and a circuit was set up on the lines shown in Fig. 1. Here the

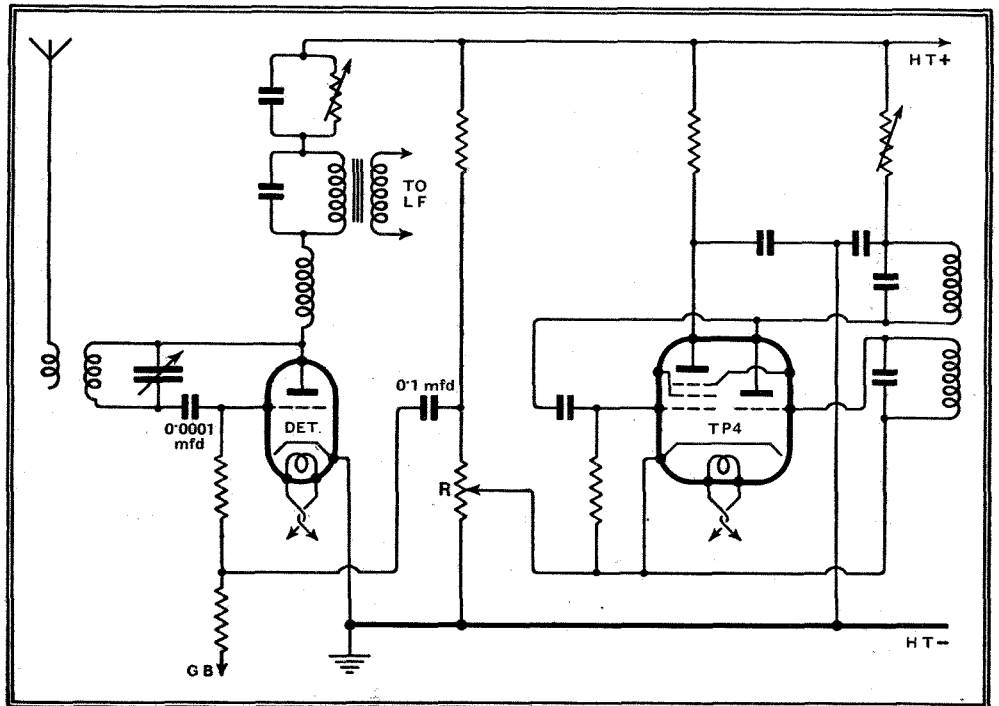

Fig. 3.—A practical version of the experimental circuit shown in Fig. 1; a triode-pentode combines the functions of quenching oscillator and wave-form corrector.

is used to give a rapid and brief but intensive quenching action, whilst the build-up period is relatively longer in duration. Combined with an increased quenching frequency to take advantage of the reduced overall period of the cycle of operations this effect has been confirmed experimentally, and is further confirmed by the fact that the optimum value of quenching frequency becomes higher when the wave-form is thus changed in accordance with the above theory.

Tests to verify this effect have been made with a normal type of super-regenerative receiver operating mainly in the five-metre amateur waveband. Normally the receiver employs a low-capacity type of detector valve followed by one AF stage. A separate quenching oscillator valve having variable frequency and amplitude controls is employed, and an optional RF stage is used before the detector to improve selectivity and reduce reradiation. The set is in frequent use and its capabilities well known.

As a preliminary test the quenching valve was disconnected and replaced by a cathode-ray time base generator giving saw-tooth wave-form which could be adjusted to similar frequency and amplitude. Tests on well-known stations

original quenching oscillator is employed again, but the potential from it is not applied directly to the super-regenerative detector, but to the grid of an intermediate valve V, which might be described as a wave-form corrector. This valve is over-biased to beyond anode current cut-off potential, which can be conveniently effected by a rather low resistance potentiometer across the HT supply with its slider taken to the valve cathode.

Modifying the Wave-form

This biasing resistance R modifies the quenching wave form and becomes quite an important control in the modified circuit. The correcting valve operates under Class "C" conditions, namely, with zero anode current, and potentials set up across its anode resistance are applied to the grid of the detector as quenching potentials. Under these conditions there will be no extra grid potential applied to the detector during build-up periods since the anode current of the corrector is zero, and hence a suitable permanent bias should be applied to the detector; this may best be obtained experimentally from a battery, and the polarity and voltage of this should be set to the value which gives the readiest and most intense oscillation of the detector. This may be found by trial for the type of valve in use by reducing reaction coupling temporarily until oscillation ceases, and finding the bias at which minimum coupling is needed.

With the corrector valve working in this manner, anode current will only flow for brief periods during the positive peaks

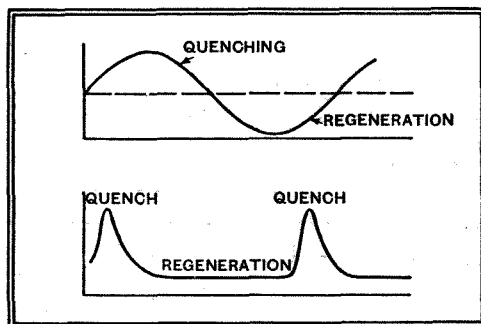

Fig. 2.—Sinusoidal quenching oscillation cycle, compared with the modified wave-form advocated by the author.

Improving the Super-regenerative Set—

of the quenching oscillation at its grid, the duration of these brief anode pulses depending upon bias applied. Thus at these instants the detector receives a quenching pulse which can be made of high intensity but short duration, whilst at other times the bias is that selected for maximum reactive build-up. A condition of maximum efficiency is therefore more nearly obtained than if the sinusoidal quenching oscillation were applied directly to the detector. If the bias to the correcting valve be reduced to the normal value for amplification, the quenching oscillation will be merely amplified and normal super-regenerative operation obtained. As the bias is increased to the cut-off point and beyond, the wave-form becomes of the nature shown in the lower curve of Fig. 2, and improved efficiency results.

The circuit just described may be criticised on two counts. First, the quenching pulse is negative and produces suppression of the oscillations by momentarily cutting off anode current in the detector, whereas a more usual method is to damp out the oscillations by the application of a positive potential and the effects of the resulting grid current. This method results in a lower quenching amplitude and more rapid quenching. Secondly, an extra valve is necessary to give the desired wave-form distortion.

Both these points are taken care of by the circuit of Fig. 3, which is that of a practical receiver now in use. Here the load resistance across which the quenching potentials are built up is moved to the cathode circuit of the correcting valve, and functions of oscillator and corrector are combined in a dual valve. Almost any triode-hexode or similar type can be adapted to this work, that used in the circuit given was a TP4, and, although the theory of operation is somewhat different, valves of the common cathode type such as the FC4 will also operate. The conditions in the circuit of Fig. 3 are similar to those in Fig. 1, the hexode section of the valve being over-biased by the resistance R. The remainder of the circuit is self-explanatory.

It is interesting to note that, owing to the extra quenching amplitude obtainable in a circuit of this type employing an amplifying stage, it is possible to employ either positive or negative pulse quenching, and interesting comparisons become possible with slight circuit alterations. The action of the super-regenerative detector is so complicated in detail by the effect of small phase displacements and by the wide range of possible amplitude relationships between the operating conditions of detector and quench that no attempt has been made to explain the operation fully; neither is it possible to measure the improvement in performance resulting from wave-form changes with the type of equipment normally available. It is a matter of great difficulty to obtain valid performance measurements at ultra-high frequencies unless exceptional facilities are available.

Fortunately, however, the circuits described lend themselves well to experi-

mental treatment, and will operate over wide ranges of conditions, and thus provide an interesting field for the experimenter.

A further modification which has been tested with success is the use of a neon oscillator of conventional type as generator of the quenching oscillation. This circuit generates a saw-tooth wave-form which seems somewhat preferable to the conventional sine wave.

The degree of improvement obtainable by the use of a modified wave-form in the manner described is not easy to assess exactly, and has not been measured for weak radio-frequency inputs. In the case of a strong signal an increase in modulation response at 1,000 cycles has been measured in the detector anode circuit as of the order of three times, which seems to be of the magnitude to be expected from the simple theory. It is found that when all is working correctly the signal strength from a distant amateur transmission increased very noticeably as the bias upon the corrector valve was increased from the linear value towards anode cut-off, the effect being aurally similar to that of turning up the audio-frequency volume con-

trol; while it cannot be said that this is exclusively due to the change in wave-form, there is little doubt that it is largely so.

After considerable practical use the writer is satisfied that this improvement in signal strength is accompanied by an appreciable reduction in noise level on distant stations, and noticeably cleaner operation, and on account of these effects the circuit can be recommended as a helpful modification to the conventional circuits.

Data on American Sets

THE second revised edition of "Radio Field Service Data" is published in loose-leaf form, and its price includes supplements for a year. The book, which is written to meet the needs of service men, contains a mass of practical information on the characteristics of a vast number of American broadcast receivers. As an aid to the location of faults, "case histories" of many of the more popular models are given.

In addition to sections on such subjects as colour codes, valve characteristics, radio formulae, etc., the problems of car radio installation are described at length. The book is issued by Radio and Technical Publishing Company, 45, Astor Place, New York, U.S.A., at the price of \$2.50.

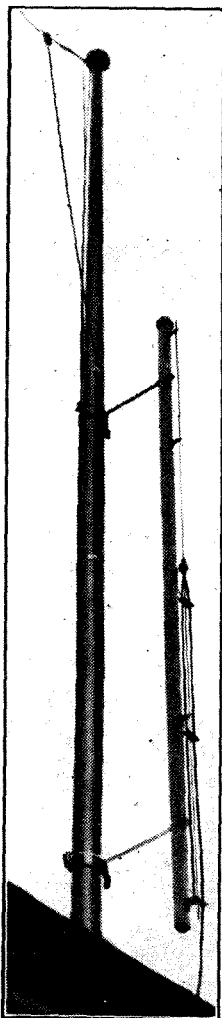

(Above) The dipole television aerial and one of the masts supporting the broadcast aerial, which is fitted with an impedance-matched screened downlead.

TELEVISION
"LAID ON"

These photographs show an extremely ambitious installation providing both sound broadcasting and television to no fewer than 73 flats in the Law Land Company's new building, Carrington House, Hertford Street, Mayfair. The community aeri- als and distribution system were installed by E.M.I. Service, Ltd.

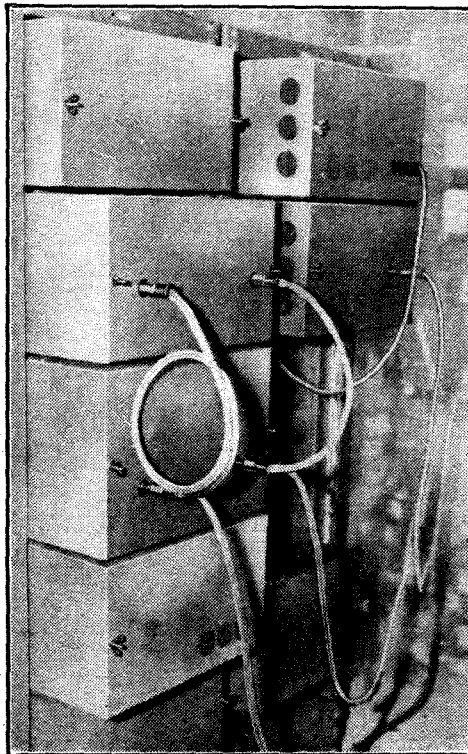

(Above) Both television and broadcast aeri- als are raised well above the field of interference.

(Left) An elaborate distributing system, with line amplifiers, ensures for each tenant a standard of reception as good as that provided by a properly installed individual aerial.

Unbiased

The Curse of Christmas Presents

I CANNOT express my thanks too warmly for the great kindness shown by all of you to the desperate appeal which I made to you, when in Lapland the other week, for homely remedies for colds and rheumatism. I am pleased to say that as a result of these my Christmas is likely to be a far happier one than I had anticipated, as my ailments seem to be lifting under the combined onslaught of several of these remedies. At this very moment I am writing these few notes with my feet in a mustard bath and various medicinal remedies hanging on the Christmas tree at my side, Mrs. Free Grid having faithfully arranged them there for me.

At the same time, while duly grateful for all these touching manifestations of your affection, there is, I regret to say, a fly in the ointment. I am, of course, referring to the traditional metaphorical fly and not the rather curious entomological specimens which I have found embedded in the chest salve which a kind reader has sent by Air Mail from West Africa. The trouble to which I refer is the apparent contradictions in the various remedies sent to me and the Spartan will necessary to carry some of them out.

The Snow-bathing Cure

Mustard baths I do not object to, while my will power is sufficiently strong to swallow many of the nauseous draughts which have been sent me, but somehow or other I cannot feel that it is beneficial to rise straight from a warm bath and then go out and roll in the snow, even though I am counselled to rub myself vigorously with the wretched stuff. My difficulties are not lessened by the fact that I have to seek the kind hospitality of a nearby frozen meat repository owing to the absence of the natural article in the garden. However, I dare say that even though at the moment of writing I feel at death's door, your remedies will pull me through.

I suppose that the great majority of you on this gladsome morning are sitting gazing glumly at the various gifts which have reached you and wondering how best you may get rid of them without offending the donors. I well recollect last year being in something of a quandary myself on this point and I find myself in a somewhat similar fix this year. Things like socks and ties are not so bad, as when you wear them they cause offence to others rather than to yourself, and even bed socks have their uses. But what on earth



Feeling like death warmed up.

possesses women to go and buy something which they know absolutely nothing about, namely, cigars.

I remember shortly after Christmas last year, Mrs. Free Grid and myself were invited one evening to a Yuletide party given by the Vicar and the Vixen. The latter lady had sent me a box of cigars for Christmas as a small token of her esteem for my efforts in reading aloud extracts from Balzac's saucy stories to the members of the Mothers' Meeting, while they were busily engaged in making red flannel waistcoats for the unfortunate natives of the Fiji Islands, and thus unable to read for themselves.

The cigars that she sent me were really so appalling that I greatly doubted whether it could have been a case, as it usually is, of an unscrupulous tobacconist taking advantage of a woman's ignorance in these matters and deliberately palming off these compressed cabbage leaves on to her. I began, in fact, to suspect that my charitable efforts had not been appreciated at their true worth, and that the cigars were sent to me with malice aforethought.

At any rate, I filled my case with them and duly handed it round to the male members of the party at the appropriate moment. The result was, however, not

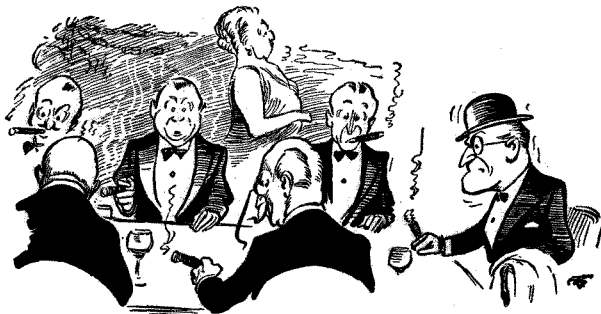

A restless feeling among those present.

quite what I had expected, for, although, as I had anticipated, a restless feeling soon began to manifest itself among those present, the prevailing bad odour was attributed to the drains, and with one or two significant remarks concerning the

disadvantages of living in old-fashioned country vicarages the guests began to totter home.

Actually, of course, as I write these words, Christmas has not yet dawned, but owing to some secret service work done by the Little Grid Leaks in return for a small fee, I am already in possession of a fairly complete list of what I am to be given this year. Fortunately, there doesn't seem to be anything particularly offensive, but I am dismayed to learn that I shall find myself the embarrassed recipient of no fewer than five television receivers, but since these are of the old 30-line type, I shall be rather at a loss to know what to do with them. It is quite obvious, of course, that some unscrupulous dealers have sold them to my ignorant womenfolk at a knock-out price as a great bargain and, as usual, I have been left to hold the baby.

By Free Grid

It puts me in a very awkward predicament as one of them is from a wealthy aunt from whom I have expectations, and in an accompanying letter, which one of the most astute of the Little Grid Leaks has filched from the parcel, she has announced her intention of coming over to my place to see the television programmes by means of her wretched set. I cannot afford to upset her by letting her know that she has been stung, as she always prides herself on her commercial slickness. Every time I think of the amount of money which is hanging on my solving this problem in the proper manner I break out in a cold perspiration which in my present state of health is, I feel sure, not at all good for me. At the present moment the only thing I can think of is to set fire to my house on Christmas Day and burn the lot. Somehow or other I cannot help feeling that this is like using a steam hammer to crack a nut, and if any of you have helpful suggestions to make, I hope you will telegraph me immediately.

However, I dare say you have plenty of Christmas troubles of your own to occupy you without bothering about mine. I will, therefore, content myself with

wishing that, at this season of good will, when even wireless manufacturers become almost human—or, at any rate, sub-human—you are able to forget all your troubles and join me in a glass of quinine.

FURTHER
NOTES
ON

Negative Feed-back Amplification

By W. T. COCKING

SOME of the more important advantages to be derived through the use of negative feed-back have been dealt with recently in "The Wireless World." In this article the effect of the input transformer is treated, and it is also shown that the system enables a filter to be properly loaded while retaining optimum operating conditions for the valve.

THE benefits to be derived from the use of negative feed-back in amplifiers embodying pentode-type valves were discussed in some detail in a recent article in *The Wireless World*.¹ It was shown that its use tends to give triode characteristics to a pentode in so far as it reduces the effective AC resistance of the valve so that the loud speaker is properly damped, it raises the signal input to the same order as that with a triode, and it reduces harmonic and frequency distortion. These advantages are very material, and are especially important in the case of DC mains apparatus where the HT voltage available is quite low. The first amplifier embodying the principle to be described constructionally was consequently of the AC/DC type, and it appeared in last week's issue of *The Wireless World*.

In this article it is not proposed to discuss this amplifier in any detail, for it has already been fully described, but rather to consider some of the practical aspects of negative feed-back. In the article already referred to, it was shown that for satisfactory

Fig. 1.—A negative feed-back circuit which gives an output resistance higher than the valve resistance.

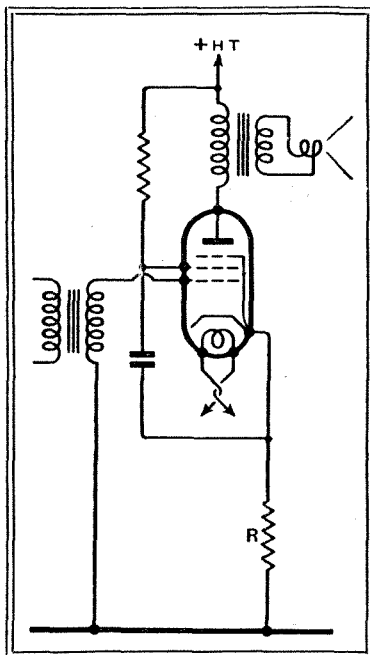

operation the voltage fed back must be applied to the grid of the valve in series with the normal input voltage. When a low output impedance is desired this feed-back voltage must be derived from a circuit in parallel with the output, but when a high output impedance is required it must be taken from a circuit in series with the output. The two arrangements are illustrated in Figs. 1 and 2.

Normally, for an output stage we use the second circuit, giving a low output impedance, but there are undoubtedly occasions when a high output impedance is desirable. More of this anon. The point

which it is now desired to raise is this: a feed-back stage will only function in the manner expected if the true voltage between grid and cathode is the difference between the input and feed-back voltages. If E_{in} is the voltage across the transformer secondary and E_f is the feed-back voltage (across R in Fig. 1 or across R_1 in Fig. 2), then the true grid voltage should be $E_g = E_{in} - E_f$.

Factors Which Influence Performance

This would be obtained if the input impedance of the valve were infinite. In practice it is not, for even if the Miller effect is negligible there is the grid-cathode valve capacity to consider. Even this would be relatively unimportant if the impedance of the input transformer, viewed from its

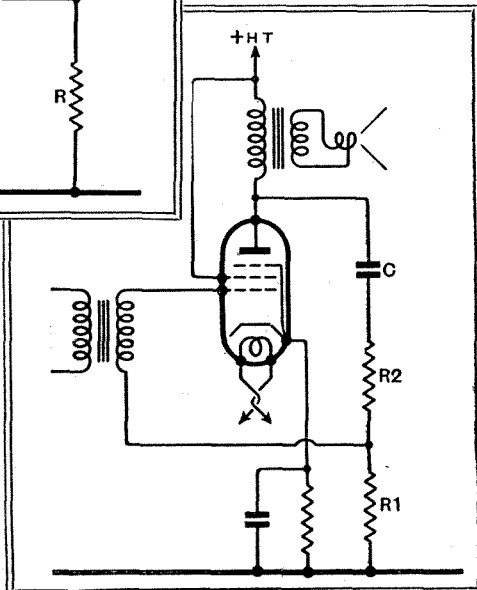
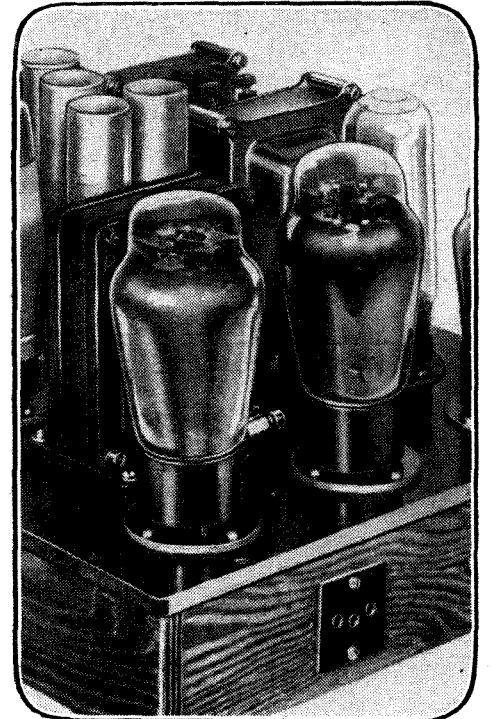

Fig. 2.—With this circuit the output resistance is lower than the valve resistance. It is consequently of wide application.



secondary terminals, were a pure resistance. The transformer impedance is complex, however: at some frequencies it is resistive, but at others it is reactive and behaves at some as a condenser and at others as an inductance. The effect of this, in conjunction with the input impedance of the valve, is to cause an alteration in the magnitude and phase of the feed-back voltage with frequency.

Frequency Response

This naturally reacts upon the frequency-response characteristic and causes unexpected results. Large peaks in the response curve are possible, for the phase change may be such that it converts negative feed-back into positive at certain frequencies, with consequent regeneration. Experience shows that in the audio-frequency range little difficulty is found in obtaining satisfactory results. A phase-shift occurs at frequencies above about 6,000 c/s, due to a resonance effect in the transformer, and the response at higher frequencies may rise considerably. It is, however, easy to avoid the trouble by damping the transformer secondary with resistance.

This point regarding frequency-response is stressed because it is usually stated that the application of negative feed-back greatly reduces frequency-distortion. This is quite true, and the amplifier as a whole

¹ *The Wireless World*, Nov. 6th, 1936.

Negative Feed-back Amplification—

tends to take on the frequency characteristic of the feed-back circuit. A flat overall response curve can only be secured when the feed-back circuit gives a uniform response and a constant change of phase with frequency. With circuits such as those of Figs. 1 and 2, however, the transformer secondary and the input impedance of the valve are really in the feed-back circuit, and may consequently upset the performance. As already stated, little trouble is experienced at audio-frequencies, but serious difficulty might be experienced at higher frequencies.

The application of negative feed-back has, so far, been considered only in relation to the output stage. There is, however, another use for it, for by its aid a problem which has long caused difficulty can be solved. This is in relation to filters. It is well known that a properly designed filter requires terminating at each end with a resistance equal to its characteristic impedance. When the filter follows a valve the valve resistance is the termination at one end, and at the other end we must have a resistance equal to that of the valve.

The filter is then properly terminated, but the valve is not operating under proper conditions, for it is working into a load equal to its own resistance instead of one which is several times that value. Hitherto there has been no solution to this difficulty, but negative feed-back, with the circuit of Fig. 1, offers a solution.

The optimum load for a valve is unchanged by the use of negative feed-back, but the apparent output resistance can be

made almost anything we like. In general, for working into a filter, we want to increase the apparent AC resistance of the valve. We thus use the circuit of Fig. 1, build the filter to have a characteristic impedance which is a suitable load for the valve from the point of view of distortion, and then apply negative feed-back to increase the apparent output resistance of the valve to a figure equal to the filter impedance.

Thus, suppose we have a 10,000-ohm valve which requires a load of 20,000 ohms. We build a filter having a characteristic impedance of 20,000 ohms and terminate it at the far end by a 20,000-ohm resistance. The beginning of the filter we connect directly to the valve. Normally it would be mismatched, for the valve resistance is only 10,000 ohms, but we can bring the effective value up to 20,000 ohms by negative feed-back. In the article already referred to it was shown that the effective output resistance of this circuit is $R_a + R(1 + \mu)$.

In this case we wish to double R_a , so that to obtain an output resistance of 20,000 ohms $R(1 + \mu)$ must equal 10,000. For a valve of this type μ may be 20, and assuming this value, $R = 477$ ohms. This is not far off the normal bias resistance for a valve of this type; if it is operated with a moderate anode voltage, however, a higher resistance may be needed to provide grid bias. The resistance can then be divided into two in series, one for feed-back and the other to make the total value that necessary for bias. This second resistance must be by-passed by a large capacity.

On the Short Waves

EXTRACTS FROM A LISTENER'S LOG

AS we move on into midwinter it is becoming more and more obvious that short-wave conditions are not going to drop out in the evenings this winter as they have done during the past five years, and that we are at last really in the sunspot maximum period.

At the moment of writing, 11.15 p.m., I am listening to W1XAL on 11.79 Mc/s (25.4 m.) at really excellent strength, R9+ and 100 per cent. intelligible; a few nights ago, too, W3XAL was quite good at 9 p.m., in fact even better than he had been at 6.30 p.m. Owing to cloud we have not been able to look at the sun for some days, but if present conditions (and as during the last few nights) are any guide, then sunspot activity must be high. This hangover of the daylight frequencies into the late night is quite typical of active sunspot conditions, and a fall in activity is generally shown by days such I mentioned at the conclusion of my last notes, i.e., the ultra-high frequencies good at sunset, then a rapid drop in the optimum frequency, even down to 4 Mc/s in the case of U.S.A. and Canada.

Reception on the ultra-high frequencies, however, seems to be good when there are either a lot of sunspots or none at all, and poor during the transition period.

With the increase in the sunspot activity,

too, the severity of the Dellinger fade-outs seems to be increasing. It will be remembered that these fade-outs are almost certainly connected with the ejection of hydrogen by the sun, and as the effect on radio occurs simultaneously with the solar eruption it seems certain that the agent which causes the radio disturbance travels with the speed of light.

It is more than probable that this agent is ultra-violet light, it also being remembered that only the sunlit part of the globe is affected, and the effect of this additional light is greatly to increase the ionisation and, consequently, the attenuation of the E region.

During recent fade-outs on twilight paths only the lowest of the frequencies in use has been affected, but on the bright daylight routes, such as the African, even the highest frequency in use commercially (Empire Station GSH, 21.47 Mc/s) and all lower frequencies have been rendered useless at times.

In order to escape this attenuation in an abnormally ionised E layer it is, of course, only necessary to increase the sending fre-

quency sufficiently, but if we do this we are not certain that it will be returned by the F₂ layer, since at the moment we are unable to say what effect the ultra-violet light has on this region during the Dellinger fade-out periods, and whether its ionisation increases proportionately with that of the E.

A study of the reception data relevant to the reception of Alexandra Palace in Johannesburg may help us to elucidate this point.

The question is, does reception on these ultra-high frequencies improve during a hydrogen-eruption fade-out?

Optimum Daylight Frequency

What does seem relatively certain is that the optimum frequency for midday transmission to Africa is going nearer to 28 Mc/s than to 21 Mc/s during the next few years!

Before passing from this brief propagation study one cannot help feeling that, in some ways, may not the clue to the future of short-wave communication be found in the so-called "Luxembourg Effect"? If high-power stations like Droitwich are able to affect the ionosphere to such a degree as to be able to impart their modulation to other stations, why should we not in future control the E and F layers (particularly the latter) in this manner?

These high-power low-frequency transmitters are able to affect the E region, and may not future high-power high-frequency transmitters create their own "ionisation" at the points where their beams strike the F region? This property would be particularly valuable (apart from cross-modulation effects—which might be avoided by the use of frequency-modulation) when the transmission path is from darkness into daylight.

Ultra-high frequency conditions seem to have been good from December 3rd to 6th, in particular W9XAZ and W2XEM having been outstanding signals, although many of the U.S. amateurs have also been putting in excellent signals on 28 Mc/s.

Monday, December 7th, appeared to be a typical day of "good conditions"; at 7.20 p.m. the following selection was logged: second harmonic of WSL on 25 Mc/s, R9; W3XAL, 17.78 Mc/s, good; W2XAD, 15.33 Mc/s, excellent; W2XAF, 9.53 Mc/s, good but for slight fading and heterodyne, which surely covers a very wide band of frequencies!

Barely an hour later, however, only W2XAF was left.

Conditions were similar on Tuesday, December 8th, and although W2XAF was again the best signal at 10 p.m. the higher frequencies were more in evidence.

Among the best stations in the 9 Mc/s group early on Wednesday evening were W1XK and Rome, the latter an R9+ signal at midnight.

As mentioned earlier in these notes, at 9 p.m. on December 10th W3XAL was still a good signal on 17.78 Mc/s, with W2XAF and W1XK good, too, at this time.

Ionisation levels seemed to be down a little on Friday, December 11th, but W2XAF was an excellent signal again at 8.40 p.m.; noise levels were low and the European stations weak this evening.

Saturday, December 12th, was notable for an extremely marked echo on GSH at midday, while GSG was similarly affected; on Sunday very good results were obtained from W2XE on 21.52 Mc/s (13.93 m.) until close down at 6 p.m.

ETHACOMBER.

EVENTS OF THE WEEK IN BRIEF REVIEW

Current Topics

New H.Q. for European Wavelength Control

NEW premises for the Brussels wavelength control authorities are said to be under consideration. The new headquarters are likely to be about a mile from the old, and will be made completely sound and vibration-proof. It is hoped that these new premises will be in use before the end of 1937.

Relay Exchanges Amalgamate

THERE has been a considerable number of complaints made concerning the unsightliness of the great number of overhead wires in Burnley. This has been largely due to the fact that, until recently, there have been no fewer than thirteen wireless relay exchanges in the district. These have now amalgamated, and the result will be a large decrease in the number of wires and also the avoidance of wasteful competition.

Japanese Wireless Components

WIRELESS manufacturers in this country have for some time past been perturbed by the flood of cheap and, in many cases, poorly designed American goods, which have been coming into this country. Now we learn that the American radio manufacturers find themselves faced with somewhat similar conditions, and are seeking to have a tariff imposed on certain cheap Japanese wireless components which have been flooding the market.

N.Z. Short-Wave Station ?

PROPOSALS are afoot to build a short-wave wireless station in New Zealand for the purpose of putting the country "on the map" so far as the rest of the world is concerned. Considerable opposition has been experienced from various quarters however. In particular the President of the Federation of the Chambers of Commerce of the British Empire has given it as his opinion that, with her limited population and great distance from the world's centres, it is extremely doubtful whether New Zealand will be able to put out programmes of a type to hold the interest of listeners overseas.

Berlin Wireless Show

THE opening date of the German Radio Exhibition for 1937 has been fixed for July 30th. It will remain open until August 8th.

A Steady Increase

FRENCH listeners continue to increase in numbers fairly steadily, and the ideal of three million, at one time considered almost unattainable, has long since been passed, the number now being 3,082,498.

Inventor Honoured

AUSTRIA is to issue a special postage stamp to commemorate Robert von Lieben, the Austrian inventor, who did a great deal of pioneer work in the development of the valve as an amplifier.

Radio Foundation Day

ON December 12th the Australian Institution of Radio Engineers commemorated the anniversary of the birth of long-distance wireless communication by a banquet at which special messages were received from the Marchese Marconi and Colonel A. S. Angwin, the Deputy-Engineer-in-Chief of the G.P.O. The day was further commemorated by means of a special message sent round the world

from Sydney via London, Bombay, Tokio, Buenos Aires, New York, Montreal and back to Sydney.

Municipal Wireless Station

THE City Council of Brisbane, the Queensland capital, has its own transmitting station which is used to communicate instructions and information to police cars, ambulances and service cars of the Electricity and Tramways Dept. which are radio-equipped. Other important Australian cities may possibly adopt a similar arrangement.

A Noteworthy Conversation

DURING the recent N.B.C. celebrations in America which were attended by the French P.M.G., the latter, while travelling in an American airship, held a short-wave conversation with the Marchese Marconi in his yacht over five thousand miles away.

Questions in the House

THE present number of radio beacons in use in this country is five, all these being of an experimental nature. According to the reply given by the Air Minister to a question raised in Parliament the whole subject of these beacons and the

wave-lengths they employ is to come under review at the next Tele-communications Convention which is due to be held in 1938. Another interesting fact which emerged as a result of a question in the House was that the total revenue from wireless licences issued in respect of receiving apparatus connected with wireless exchanges (i.e., loud speakers and auxiliary gear) amounts to nearly £120,000 per year. Ten per cent. of this revenue is retained by the Post Office.

Free Aerials for All

ALARMED at the damage done to the tiles of council houses through careless fitting of aerials, the Kirkcaldy town council is considering a proposal to erect a wireless aerial in the case of each new house built. This proposal is viewed with considerable favour by local wireless traders, who consider that the existence of an aerial already erected will encourage more people to purchase sets.

Have You Heard It ?

HAVANA COCD is now broadcasting programmes in English, German, French and Spanish between 10 and 11 p.m. (G.M.T.). The wavelength used is 48.92 metres (6,130 kc/s), and the power is 250 watts. In spite of the low power this station is said to be coming in at considerable strength in this part of the world, and it will be interesting to know how many of our readers have picked it up.

Wireless-equipped Rocket

IT is reported from Germany that a giant stratosphere rocket is being constructed to rise to a height of ten miles or so. It is to be fitted with an automatic transmitter designed to signal to receiving stations below what height it actually reaches. Special apparatus is also to be installed so that on its descent it can be guided by wireless to a suitable landing place where it will do no harm.

Airman Praises DF

A REMARKABLE tribute to the efficacy of wireless direction-finding has been made by M. André Japy, the hero of the recent Paris-Tokio flight. He stated that had it not been for DF he would never have been able to reach Hanoi. Meteorological conditions were so bad that ordinary navigational methods were virtually impossible, and he was compelled to rely solely on DF.

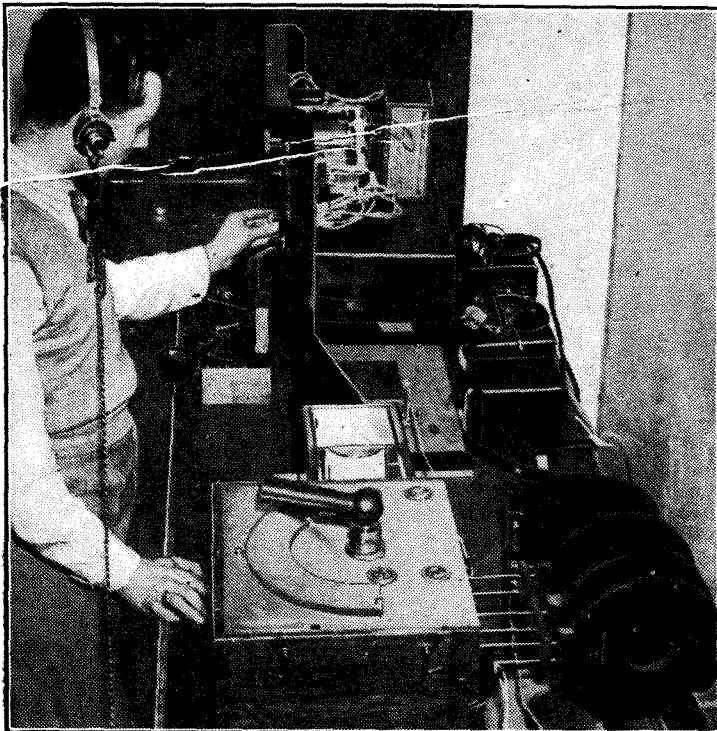

THE G.P.O.'S OFFICIAL WAVEMETER. A constant watch has to be maintained by the G.P.O. Engineering Dept. for frequency drift on the part of its wireless transmitters. The multi-vibrator wavemeter shown here undergoing tests at the Dollis Hill Laboratory is shortly to be installed in the Post Office central receiving station at Baldock for checking purposes.

BROADCAST NEWS FROM PORTLAND PLACE

BREVITIES

More, and Yet More

IN an almost constant stream of talk and music, the B.B.C. has agitated the ether this year—from January 1st to November 30th—for 71,608 transmission hours. This beats the record of 1935 over the corresponding period by 2,813 hours.

The increase is due partly to increased loquacity and partly to the opening of North Scottish in October last.

Bigger Breakdown Percentage

ARE the regional stations beginning to show the first signs of deterioration? A hint of this is contained in the transmission logs for 1936, which reveal a breakdown percentage of 0.031, as compared with 0.026 in the previous year.

Weather conditions, of course, play their part in mishaps due to aerial failure, and in justice to the B.B.C. it should be remembered that 1936 weather has been decidedly worse than that of 1935.

A Seventeen-hour Day

The above figures do not take Empire broadcasting into account. During 1936 the Daventry transmitters were working at high pressure for an average of seventeen hours a day, the total transmission time to November 30 being 12,608 hours.

Wireless in Rural Schools

JOHN BULL'S children are becoming a generation of pupils nurtured on the broadcast lesson. Figures which have recently been compiled at Broadcasting House show that some 1,300 rural schools are now upon the listening register, the children thus having the benefit of equal facilities with the pupils of schools in the big towns for education by wireless.

Damp Squib

IS correspondence a useful guide for the programme compilers as to listeners' likes and dislikes? It is very much to be doubted, in view of recent experience at Broadcasting House. Here is a case in point. It was wrongly reported in a section of the Press that the B.B.C. was proposing to broadcast a macabre programme, and immediately a petition of protest, bearing fifty-nine signatures, was

received from a town in the Home Counties. In addition, individual letters of protest came to hand, but it was found on examination that several of them were in identical handwriting, although they bore different addresses and different signatures. It was also found that the same signatures were contained in the petition.

Faking Correspondence

Which reminds us of a dodge practised freely in the early days of broadcasting, when some artists new to the air used to spend quite a large sum out of their fees in preparing postcards containing appreciative comments. The cards were distributed among their friends for posting back to the B.B.C. The programme correspondence section at Broadcasting House is fully alive nowadays to the need for paying attention to the opinions of bona fide correspondents only.

Prize Fight Commentaries

THERE may be an opportunity for a new type of prize-fight commentator before the next big match is "staged"

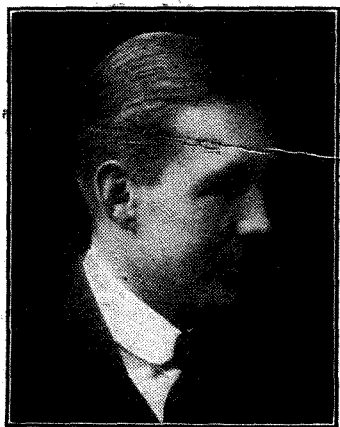

TWO NEW GOVERNORS have been appointed to the Board of the B.B.C. They are Sir Ian Fraser, M.P., the blind Chairman of St. Dunstan's, well known to *Wireless World* readers and—

for listeners. Complaints have been received from many quarters, even as far afield as Bermuda, that as the enthusiasm of the vast crowds present at these events waxes, the interest of listeners tends to wane, for the reason that the voice of the commentator, usually cultured and smooth, cannot be heard above the frenzied din of the on-lookers.

Wanted: A Voice of Thunder

What is wanted is, it is felt, a commentator of the calibre of a Lionel Seccombe with the stentorian roaring qualities of a circus showman. It has even been suggested that the B.B.C. has within its own walls a man who could "fill the bill" satisfactorily. He is known to his colleagues as "Sergeant," because he held that rank in the War. In his spare time he acts as M.C. at a boxing establishment. He knows the game from A to Z and has a voice like the bull of Bashan. But perhaps the simplest solution is the arrangement described on p. 549 of *The Wireless World* of June 5th, 1936. Whether technical obstacles can be overcome so as to render even a voice of thunder audible above the clamour of the masses is a matter for investigation.

Softening the Blow

LISTENERS stand to gain, indirectly, by a benevolent gesture which the B.B.C. has just made towards its staff. The Corporation's aim is to ward off anxiety, in the belief that freedom from unnecessary apprehension will increase the efficiency of the staff and result in a better broadcasting service.

In essence it has been decided that members of the staff shall have the right to generous treatment if the Corporation terminates their service. In addition to the notice legally due, people given "the key of the street" will hereafter be entitled to a month's salary in respect of each year's service (after the first year) with the B.B.C.

Of course, even the B.B.C. must draw the line somewhere. This generous treatment does not apply in cases of resignation.

Television Nightmare Ended

THERE was excitement in the Baird camp at Alexandra Palace last week, when a new type of spool arrived for the intermediate film apparatus. This is double the size of the spools hitherto used, and enables continuous working for forty minutes.

In the past it has not been possible to televise with this system for more than seventeen or eighteen minutes at a time, con-



—DR. J. J. MALLON, who is Warden of Toynbee Hall, the educational institution of the East End of London.

sequently awkward cuts have had to be made in studio productions, notably plays, with interludes in the spotlight studio, while the "I.F." was being prepared for the next run.

Few sights are more agonising than the look on the face of producers as the seventeen-minute safety mark is passed, and, with the actors still merrily doing their stuff, the film threatens to run out. Such nightmares are now things of the past.

Electron Camera Taking Over

Ironically enough, despite this improvement, the intermediate film gear seems to be yielding place to the electron camera, two specimens of which are now in more or less constant use in the Baird studio.

Television: Spring Plans

TELEVISION talks, with illustrations and demonstrations, really come into their own during the next three months. Cecil Lewis, who has already made a name for himself in television as organiser of "O.B.'s," is responsible for a spring schedule which includes first-aid displays by the St. John Ambulance Brigade; cookery demonstrations by the famous chef, M. Boulestin; a feminine feature, "The World of Women," in which many distinguished women will take part; and "The Instruments of the Orchestra," a series by Philip Thornton, in which viewers will see and hear the component parts of a modern orchestra and the ancient instruments from which they originally sprang.

Other promising items in television are interviews between film stars and their directors—with excerpts from their current productions—gardening demonstrations by C. H. Middleton, and fortnightly appearance of "Friends from the Zoo," under the tutelage of David Seth-Smith.

New Apparatus Reviewed

RIDCO RANGER SW CONVERTER

THIS converter is made by Radio Industries Development Co., Birch Street, Hanley, Staffs, for use with any AC mains broadcast set for the reception of the short waves. It has one multiple valve, a Tungram TX4, which is a triode-hexode frequency changer. There is a tuned circuit in the oscillator section, but the signal circuit is aperiodic.

HT and LT for the converter are taken from the broadcast set by means of a valve adaptor. The HT can be taken either from the auxiliary grid of an output pentode or from the screen-grid supply of an RF or IF stage in sets having triode output valves. For our tests the HT was obtained from the RF stage, since the receiver used was a straight four-valve set.

The converter has two wave-ranges covering 15 to 35 and 33 to 85 metres respectively, these wavebands being selected by a switch.

Good signals were obtained from most of the medium- and high-power short-wave stations on the Continent in daylight, while during the evening American short-wave broadcast was received at good strength when conditions were favourable.

On several occasions W2XAD on 19.57 metres and W3XAL on 16.87 metres were heard in the late afternoon.

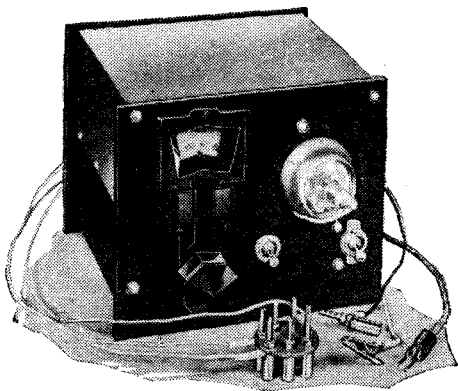

Ranger model short-wave converter for use with AC sets.

The absence of a tuned signal circuit was responsible for some interference, but often this could be ameliorated by tuning the broadcast set to a frequency higher or lower than that recommended, which is 150 Kc/s or 2,000 metres.

Considering the simplicity of the circuit employed the unit performed very well, and will undoubtedly meet the needs of those requiring an inexpensive converter for short-wave listening. It costs 37s. 6d. complete.

FERRANTI DRY ELECTROLYTIC CONDENSERS

THE latest Ferranti dry electrolytic condensers are assembled in insulated cases, some taking the form of rectangular waxed cartons, while others are enclosed in tubes of bakelised material. Condensers of from one to 32 mfd. are available, the peak potentials covered by the series ranging from 6 to 500 volts.

The new series thus caters for practically

RECENT PRODUCTS OF THE MANUFACTURERS

all requirements, be it HT smoothing or anode and grid circuit decoupling. There are some multiple types which are made in 8 + 8 and 16 + 8 mfd., and with either the negative or the positive common to both

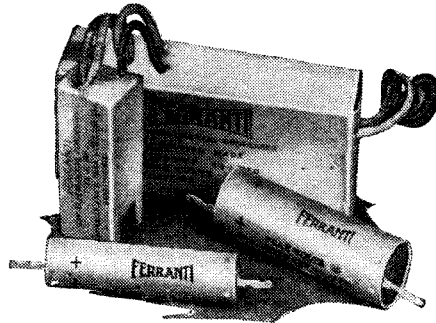

Selection of new Ferranti dry electrolytic condensers, comprising 8+8 mfd. 500 volts, 4 mfd. 350 volts, 50 mfd. 25 volts, and 1 mfd. 500 volts types.

condensers, and they are intended for use in circuits up to 500 volts peak or 450 volts working potential. Like all electrolytics these condensers can only be used in DC circuits.

The tubular models are mostly for low voltage circuits, the majority being rated for from 6 to 50 volts peak working. Two are, however, of the high-voltage type, their capacities being 1 and 2 mfd. respectively, and the former is a 500-volt type, while the latter is rated at 350 volts.

Several samples of these new condensers have been tested and in every case the leakage current was well within the figure given by the makers. It varied from about 0.2 to 0.5 mA, according to the type and capacity. All the models tested showed their full rated capacity after polarising and every condenser functioned correctly and without fluctuation in the leakage current when subjected to the maximum peak DC potential for which it is designed.

One of the dual condensers, the CE 100A of 8 + 8 mfd. was tested for destruction, that is to say, the voltage was slowly increased until the internal insulation punctured. This model successfully withstood a voltage of 540 DC, but began to spark internally on exceeding 550 volts and eventually broke down entirely at just below 600 volts. Both condensers in the carton behaved in the same manner.

At no period of the tests on any of the condensers were signs of failure experienced with potentials up to the maximum for the type, and only when the limiting voltage was exceeded by an appreciable amount did failure occur. A satisfactory margin of safety is therefore allowed in these new Ferranti condensers.

Prices are very reasonable; a 4-mfd. 350-volt model costs 2s., one of 8 mfd. for 500 volts 3s. 6d., and an 8+8 mfd., also for 500 volts, 5s. 6d.

With but one exception, the tubular electrolytics cost 1s. 9d. each, the exception being the 50 mfd.-50 volt model, the price of which is 3s. 6d.

OMNISECTION VALVE TESTER

THIS valve-testing unit has been evolved for the purpose of checking the emission of any valve, but it is not solely an emission tester. Actually it achieves more than this, as it also enables an internal disconnection of any electrode to be located in a simple manner.

It does not enable quantitative measurements to be made, but the circuit is so arranged that if the valve is in good order it shows a certain reading on the meter, and all valves give approximately this same reading if sound.

On the meter scale is a small red mark, and if the pointer shows a current value less than this the valve is in most cases below standard in its performance. Provision is also made for testing the electrodes individually, a simple plug and socket arrangement serving to make the necessary changes from a "lumped" emission test to selective tests.

The tester is simple to operate, and the only adjustment necessary is that of filament voltage. A series of sockets and a wander plug enable the correct voltages to be selected for almost every type of valve in general use. Six valve-holders are fitted as well as a series of sockets on the panel; the former are for American and British nine-pin and side-contact valves, while the sockets are for standard 4-5- or 7-pin valves.

Tests made on the unit show that it does all that the makers claim and gives a reliable indication of satisfactory emission, and also enables individual electrodes to be checked for continuity with their respective pins. The indication afforded when tests were made to anode electrodes only of RF tetrodes and pentodes was inadequate.

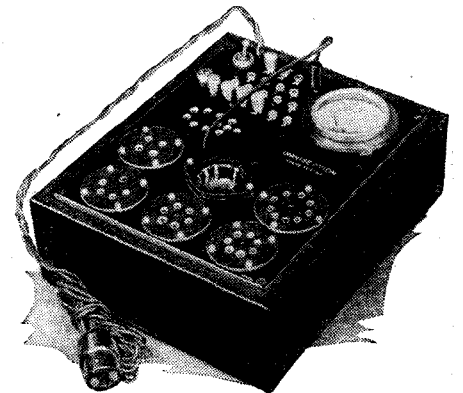

Omnisection valve tester, a unit that not only checks the emission of any valve but also enables tests to be made on individual electrodes.

since the very high AC resistance of the anode-cathode path precludes a useful reading being obtained. With triodes, output pentodes, diodes and rectifiers the instrument functions in a perfectly satisfactory manner.

The Omnisection valve tester, which is entirely AC-mains operated, is obtainable from Norman Rose (Electrical), Ltd., 94, Tottenham Court Road, London, W.1, and the price is £4 10s.

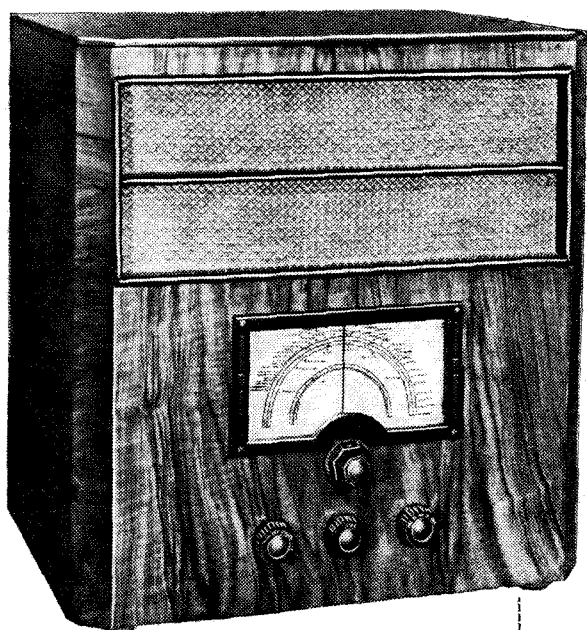

Hyvoltstar

"Battery-Mains Receiver"

An AC/DC Superheterodyne with Auxiliary Battery Supply

FEATURES. Type.—Transportable superheterodyne for operation from AC mains, DC mains or batteries. **Wave-ranges.**—(1) 16.6 to 53 metres. (2) 195 to 570 metres. (3) 900 to 2,000 metres. **Circuit.**—Heptode frequency-changer—var-mu pentode IF amplifier—double-diode-triode second detector—pentode output valve. Half-wave valve rectifier (for mains operation). **Controls.**—(1) Tuning. (2) Volume and on-off switch. (3) Tone. (4) Waverange. (5) Battery-mains change-over switch. **Price.**—21 guineas (including batteries). Carrying case 2 guineas extra. **Makers.**—Universal High Voltage Radio Ltd., 28/29, Southampton Street, Strand, London, W.C.2.

WHEN the set manufacturers or their publicity agents first applied the term "universal" to receivers which could be operated from either DC or AC mains they no doubt regarded the possibility of the development of sets with an even greater versatility in the matter of power supply as remote. In the first place, the technical difficulties of reconciling the special demands of mains and battery operation are formidable, and, secondly, the demand for a truly universal receiver of this type was no doubt regarded as limited. It would seem, however, that there is a much wider market than was at first thought, and this has encouraged Universal High Voltage Radio Ltd. to

tackle the problem of design in earnest. The set they have produced should prove invaluable to people whose business takes them into unexpected places and who cannot foretell the nature of the mains supply, if any, which may be available in their next port of call. Not the least attractive feature of this set is that they will not be deprived of wireless reception while travelling, and even for stay-at-home folk the receiver should commend itself if only for the fact that there is always a stand-by in the case of failure of mains or mains valves when a transmission of national importance is imminent. The basic circuit for both mains and battery operation is a four-valve superheterodyne consisting of a frequency-

changer preceded by band-pass tuning on medium and long waves and followed by a single stage of IF amplification, a double-diode-triode providing AVC and an output pentode valve. The valves used for mains operation are taken from the Ostar-Ganz range, in which the filament heaters are of the high voltage type, and the battery valves are of Tungsum manufacture. Both sets of valves are provided with bases of the multiple side contact type, and all the subsidiary changes of circuit conditions required when changing over from mains to battery valves are made by a change-over switch at the back of the chassis. The filament and cathode connections are, of course, automatically changed when the valves are replaced, and all that the change-over switch is required to do is to substitute a direct connection for the potentiometer feed to the screen of the IF amplifier and to change over from cathode biasing arrangements to a pre-set biased potentiometer connected between -HT and -LT. The battery cable is connected to a five-pin valve socket, the centre contact of which ensures that the battery dial lamp shall not be accidentally burnt out when returning to mains operation. A half-wave rectifier valve supplies the HT current under mains operating conditions and an independent smoothing choke is provided, since the moving-coil loud speaker must of necessity be of the permanent-magnet type.

The performance as far as range and selectivity is concerned shows no change

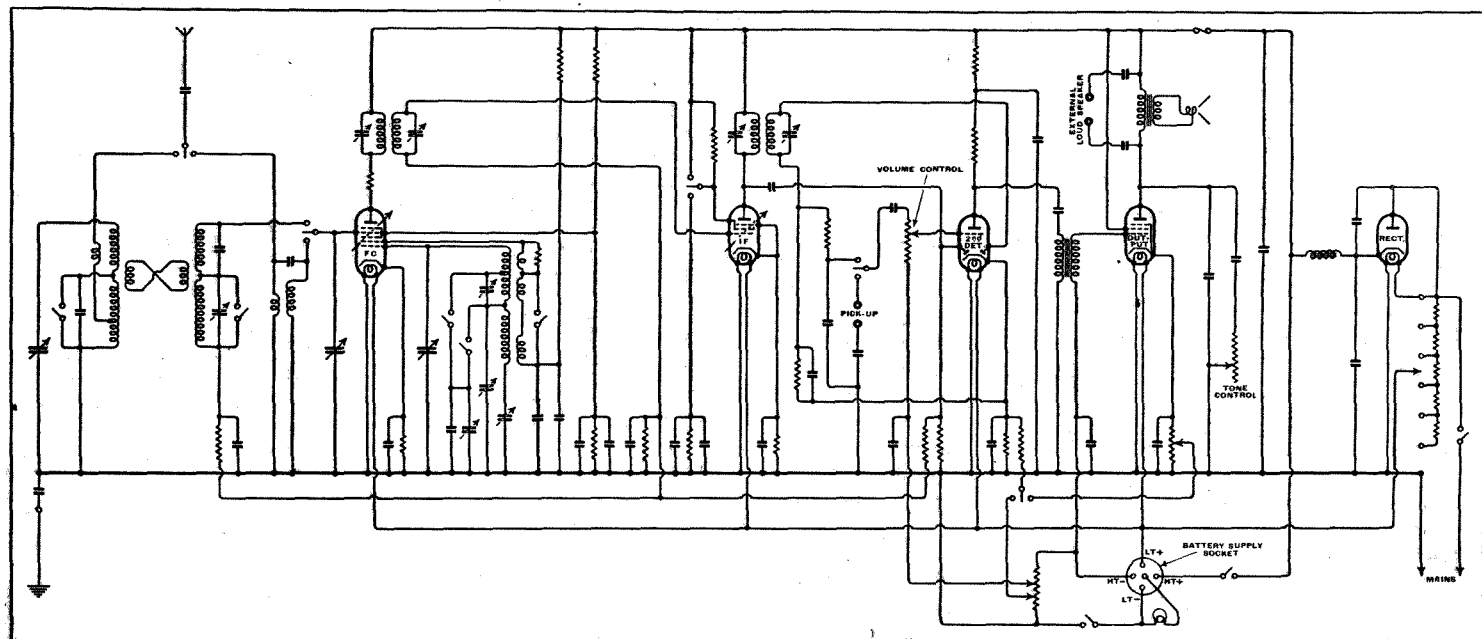

COMPLETE CIRCUIT DIAGRAM.—The various switches employed in changing the circuit from mains to battery operation are controlled from a single knob at the back of the chassis.

Hyvoltstar "Battery-Mains Receiver"

when the receiver is switched over from mains to battery operation. There is a really sparkling performance on the medium wave-band and at least fifteen foreign stations are receivable in Central London at good programme strength

The quality of reproduction is admirably suited to the all-round usefulness of this receiver, and the loud speaker deals equally smoothly with gramophone records and all the various degrees of quality which are encountered in a long-range receiver of this type. Although the cabinet

valves near the front panel. Although the cabinet is, perhaps, in the transportable rather than portable class, its proportions are compact, and the leading dimensions are 18in. high x 16½in. wide x 12in. deep. The design is along conventional table-model lines, but a special reinforced canvas carrying case is available for its protection in transit.

The set gives an excellent account of itself on a self-contained directional aerial or a short flexible indoor aerial, either of which may be supplied with the receiver.

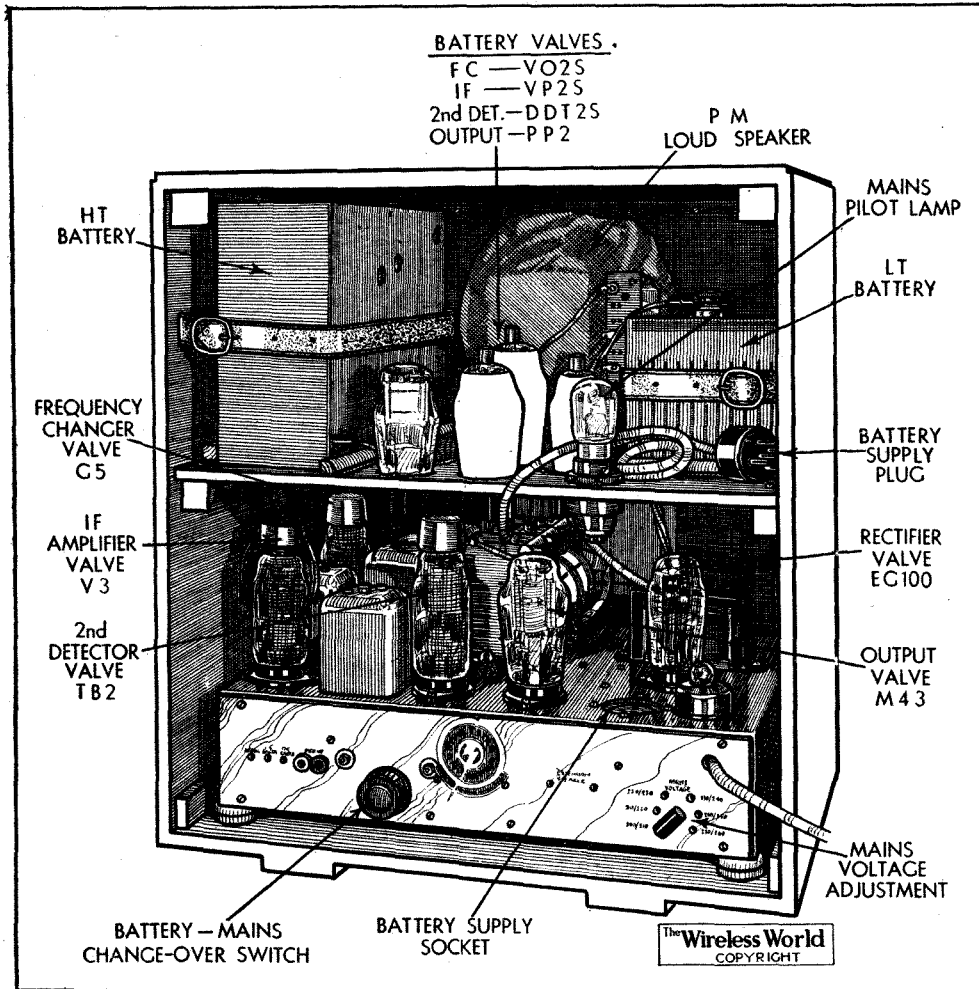

The receiver arranged for mains operation with the alternative valves plugged into dummy sockets on the battery shelf.

during the hours of daylight. The selectivity is good and the spread of the local stations does not amount to more than 1½ channels on either side of the normal setting. On long waves, while the sensitivity is in every way comparable with that of the medium-wave band, the selectivity is only sufficient to provide comfortable separation between Droitwich and Radio-Paris. There was also a tendency for the oscillator to cease to function at the bottom end of the long-wave scale, but this may have been a property of the particular receiver tested.

The short-wave range exhibits all the liveliness of the medium-wave band and has a remarkably quiet background between stations—almost as though QAVC had been deliberately introduced. In the absence of a preselection HF stage there are, of course, double tuning points for each station, but these are so close together that there can be no possible excuse for confusion as to the identity of a station. American broadcasting came in with ample reserve of power, and W2XAD provided a thoroughly reliable programme throughout the full period of our tests.

is deep from back to front it is well filled with components, batteries, spare valves, etc. This no doubt accounts for the complete absence of unnatural resonance in the bass. The upper middle register is also unusually clean, and the brilliant passages of music are reproduced without the slightest trace of harshness. The tone control is uniformly distributed throughout the range of the resistance, and it was found that, due to the small amount of background noise on short waves, practically the full high-frequency response of the loud speaker could be usefully employed under all conditions.

It is important in a receiver of this type that one should always be able to rely on the battery side of the circuit, and for this reason it is gratifying to find that the LT accumulator has a capacity of 24 amp. hours, which is more than adequate for the small total filament consumption of 0.4 amp. The 141-volt HT battery is also of large capacity, and the measured total current drawn from it is 15 mA.

The batteries and spare valves are mounted on a quickly removable shelf which gives access to the pilot lamps and

Television Programmes

The principal items only of each day's programmes are given. The system to be used each day is given below the date. Transmission times are from 3-4 and 9-10 daily.

Vision	Sound
6.67 m. (45 Mc/s).	7.23 m. (41.5 Mc/s).

FRIDAY, DECEMBER 25th.

(Marconi-E.M.I.)

3, Demonstration of Carving a Turkey. 3.15, News Reel. 3.25, "A Lonely Christmas in the Arctic"—Edward Shackleton. 3.30, Fourteenth Picture Page.

9, The Singing Boys from St. Mary-of-the-Angels Song School. 9.10, Film: A Seasonal Tour Through the Empire. 9.22, Some Unusual Christmases—Commander A. B. Campbell. 9.27, News Reel. 9.35, Television Party—Distinguished artistes from stage and screen will be guests of the B.B.C. with Cecil Lewis as host.

SATURDAY, DECEMBER 26th.

(Marconi-E.M.I.)

3, Bruce McLeod—Punch and Judy, and Sutherland Felce, conjurer. 3.15, News Reel. 3.25, Variety.

9, Bruce McLeod—Punch and Judy, and Russell Swan, conjurer. 9.15, News Reel. 9.25, Cabaret.

MONDAY, DECEMBER 28th.

(Baird.)

3, The Irish Players in "The Workhouse Ward." 3.25, British Movietonews. 3.35, Variety.

9, Repetition of 3 programme. 9.25, Gaumont-British News. 9.35, Variety.

TUESDAY, DECEMBER 29th.

(Baird.)

3, The Art of Home Washing—Mrs. Daisy Pain. 3.20, Cartoons—Bert Thomas. 3.35, Gaumont-British News. 3.45, Television Orchestra.

9, Repetition of 3 and 3.20 programmes. 9.35, British Movietonews. 9.45, Starlight—Ambrose and Evelyn Dall, with the Television Orchestra.

WEDNESDAY, DECEMBER 30th.

(Baird.)

3, Discussion between John Hilton and Cecil Lewis—"The Pattern of 1936"—a review of trade and unemployment, etc. 3.25, British Movietonews. 3.35, Fifteenth Picture Page.

9, Joan Luxton's Children's Theatre Company. 9.30, Gaumont-British News. 9.40, Sixteenth Picture Page.

THURSDAY, DECEMBER 31st.

(Baird.)

3, Conjurer. 3.20, Gaumont-British News, 3.30, London Characters. 3.40, Cabaret.

9, Conjurer. 9.20, British Movietonews. 9.30, London Characters. 9.40, Cabaret. 9.50, "Diary for 1936," introduced by Leslie Mitchell.



there. Larry Adler, who rushed over to Hollywood to appear in "The Big Broadcast of 1936," is now back in the variety theatres, and will broadcast for the first time since his return. Norman

"THEY ALSO SERVE . . ."
The control room at Broadcasting House suitably decorated for those whose duties keep them at the helm of broadcasting during the holidays.

Long, with "a song, a smile and a piano," and Kenneth and George Western, the Two Cads, are also billed. So tune in at 9.20 (Nat.).

1936-1937

THE New Year's Eve programmes from the National transmitter include some interesting new features. At 11 we shall be given a survey of some of the old customs associated with the welcoming of the New Year and some of the ways in which people to-day will see the Old Year out and the New Year in. Following this, at 11.45, we shall be switched over to St. Michael's, Chester Square, for a short Watch-night Service conducted by the Rev. W. H. Elliott. Then at midnight listeners will hear Big Ben sound the death knell of 1936 and they will then be taken to the Chelsea Arts Ball where John Watt will describe, whilst meandering among the crowds, some of the scenes and the gaiety with which the revellers will be welcoming 1937, and then as a contrast we shall be taken to see how country folk are spending the first hours of the New Year.

To conclude, many parts of the British Isles will be visited whence New Year's greetings will be broadcast.

"SONGS YOU MIGHT NEVER HAVE HEARD"

THERE must be on many a musician's shelves manuscripts of melodies and songs that have never reached the publisher and therefore would forever remain unknown to the public. Eric Maschwitz has hit upon the bright idea of

Listeners' Guide

Outstanding Bro

bringing these into the light of day by arranging a series of programmes introducing them. The first of these will be broadcast at 8.15 (Reg.) on Tuesday, when listeners will be asked to vote for their popularity. All the songs have been selected by a committee which include such diversity of tastes as those of a shopgirl, a postman, a policeman, a nurse and a pageboy.

Many well-known broadcasters are booked for this programme, including Elsie Carlisle, Morgan Davies, Esther Coleman and Robert Ashley.

FROM THEATRES

DURING this week two outstanding broadcasts take place from London theatres. The first is on Boxing Day at 8.30, when Regional listeners will be taken over to the Gaiety Theatre to hear an excerpt from Leslie Henson's "Swing Along." The second is on Thursday at 8.15 (Reg.) when listeners will hear the pantomime "Cinderella" from the Coliseum. The first part will be a recorded programme showing how Cinderella was written, cast, produced and rehearsed, and then part of the actual performance will be relayed. This programme is being produced by Laurance Gilliam and John Watt.

Details of the week's Television programmes will be found on p. 675.

HAVING already seen so much in print relating to Christmas Day broadcasts, listeners must be wondering what exactly will be "on the air." There has, however, been little change in the arrangements since the publication of the article "Christmas Wireless Fare" in our issue of December 11th.

Only one news summary will be broadcast, and that will be at 9 on both National and Regional wavelengths.

One outstanding item which was not mentioned in our Christmas number, as arrangements were not then complete, is the concert of Christmas Music consisting of contributions from the various Regions, transmitted Nationally from 9 to 11.

It starts with the Midland Orchestra playing the first movement of Corelli's "A Christmas Concerto." Then at 9.40 the Nantyffyllon Children's Choir and Welsh Orchestra will supply music of Wales. At 9.55 traditional carols of Cornwall and Dorset will be sung by local choirs followed by the choir of St. Mary Redcliffe Church, Bristol, singing a selection of carols of other countries. Music of Northern Ireland will be rendered by the Northern Ireland Orchestra at 10.10, and at 10.25 the Hallé Chorus and the Northern Orchestra will give a programme of Christmas choral music. Then on to Scotland where at 10.40 the Scottish Orchestra will play seasonable Scottish music and, as an epilogue at 10.55, the final movement of "A Christmas Concerto."

RADIO PARTY

REFERENCE has already been made to the annual radio Christmas party which will be broadcast Nationally. No details are given except that it will include all the well-liked and ever-popular games and amusements of the good old family party, and listeners are invited to tune in at any time between 7 and 9 and join in the fun.

BROADCAST SERVICES

Two services are included on Christmas Day—from St. George's Chapel, Windsor, in the morning at 10.45 when the Very Rev. A. V. Baillie, Dean of Windsor, will give the Address, and in the evening at 6 from the Concert Hall, Broadcasting House, when the Rev. Leslie Weatherhead, of the City Temple, will give the sermon during the service, which will include carols.

On Sunday the B.B.C. singers, under the direction of Sir Walford Davies, will form the choir for the service from Lambeth Palace to be broadcast at 8 from both the National and Regional stations. The address will be given by His Grace the Archbishop of Canterbury.

MUSIC HALL

BOXING DAY would not be complete without its regular Music Hall. Knowing this, the producer, John Sharman has been at great pains to rope in the best cast possible. This is a difficult day for radio Music Hall as so many of its shining lights are billed in the great variety theatres all over the country. Elsie and Doris Waters, however, will be



e for the Week

roadcasts at Home and Abroad

OPERA

CHRISTMAS DAY is rich in opera transmissions from abroad and commences with the 2 o'clock Budapest I interpretation of Humperdinck's "Hansel and Gretel"—an opera which, with its quiet charm, achieved immediate popularity and has always been regarded as the composer's masterpiece. The libretto was written by his sister and the work was intended for a children's Christmas celebration at his own fireside, but so popular has it grown that it is to be found in the permanent repertoire of every European and American Opera House. This fairy story will also be heard on Boxing Day as a studio production from Strasbourg at 8.30 and Acts 1 and 2 as a relay from Sadler's Wells by National listeners at 2.30.

On Christmas Day, also, Leipzig gives at 4 a performance of another fairy opera—Pfitzner's "Christelflein." The performance is a recorded one by the Hamburg Station Orchestra, Women's Choir and soloists, with the composer conducting. Königsberg also presents this opera at 7.30 on Sunday.

OPERETTA

ON Friday at 6.45 Vienna stages as a studio production

WINDSOR CASTLE, with St. George's Chapel right centre, seen from the Thames. This Royal Chapel will be the scene of the Christmas Morning service.

Lehar's "Merry Widow" with Holzer conducting. This will be relayed by Strasbourg. Paris PTT at 8.30 on Sunday gives "Ciboulette" (Hahn)—an excellent example of the light frothy type of modern French operetta, produced in the studio. Hahn is chiefly noted for his composition of good songs, and it is this branch of his art which makes "Ciboulette," his one operetta, so very popular both in France, the country of his adoption, and abroad.

Monday brings French light opera at its best as the 9 o'clock Strasbourg programme. We are to hear Adam's "Nuremberg Doll" and Lecocq's "Le Myosotis" (in that order) as a studio production, with the station musical director, M. de Villers, conducting.

NORWEGIAN CHRISTMAS

AN interesting cross-country series of O.B.s will be given over the Norwegian network on Christmas Day from 6.30 to 8.50 under the heading "Christmas In Norway." The microphone will wander from a lonely lighthouse far away in Northern Norway to a wedding in the south, visiting prominent people, peasant homes and many others, thus giving a collective sound impression of the Land of the Midnight Sun.

THE MARNE

HAMBURG, with its 7.10 programme on Monday, will make an appeal to listeners with a knowledge of German, for a war play by Edgar Maass, entitled "The Tragedy of the Marne" is announced. This will be a dramatisation of actual events of September 8th and 9th, 1914, dealt with by the playwright as a critical point in German history.

NEW YEAR'S EVE

THE most generally interesting programmes on Thursday are those celebrating the approach of the New Year and in most cases occupy the ether from about 7 carrying on into

HIGHLIGHTS OF THE WEEK

FRIDAY, DECEMBER 25th.

Nat., 2.15, Coventry Hippodrome Orchestra 3.45, Hastings Municipal Orchestra. 7, Radio Christmas Party 9.20, Music for Christmas.
Reg., 3.15, B.B.C. Military Band and Men's Chorus. 8.30, "The Christmas Journey"—Masque of the Nativity. 9.20, Henry Hall's Christmas Tree.

Abroad.

Radio-Normandie, 6, Carillon Recital of Christmas Carols, relayed from Rouen Cathedral.

SATURDAY, DECEMBER 26th.

Nat., 2.30, "Hansel and Gretel" from Sadler's Wells 9.20 Music Hall.
Reg., 3.15, Harlequins v. Richmond. 4.5, Pantomime, "Sinbad the Sailor." 9.20, Discussion, "Is Fleet Street what it was?"

Abroad.

Deutschlandsender, 7, "Bright Lights and Dancing"—Gala programme.

SUNDAY, DECEMBER 27th.

Nat., 6.55, "The Shadow" (Hans Andersen), 7.30 Recital—Walter Widdop
Reg., 7.30, Vitya Vronsky and Victor Babin—two pianofortes. 10, Melodies of Christendom—31.

Abroad.

Leipzig, 5.30, "Der Rosenkavalier."

MONDAY, DECEMBER 28th

Nat., 7.20, Entertainment Parade—Recital—Isolde Menges and Kathleen Long.
Reg., 6, Reginald King and his Orchestra. 8.20, "The Roosters." 9, "The Nailers"—a Black-Country play

Abroad.

Hamburg, 8, A Gala Concert of Franz Schubert's works.

TUESDAY, DECEMBER 29th.

Nat., 6.25, Pianoforte Recital—Irene Kohler. 8, "The Nailers." 9.35, B.B.C. Theatre Orchestra and Raymond Newell.
Reg., 8.15, "Songs You Might Never Have Heard." 9.30 Budapest University Chorus.

Abroad.

Hamburg, 7.10, Folk Songs and Dances of the Austrian Alps

WEDNESDAY, DECEMBER 30th.

Nat., 6.40, B.B.C. Military Band and Margaret Balfour. 10.15, "Only a Shop Girl"—Musical Burlesque.
Reg., 7.30, "The World Goes By." 8, "Light Fare"—Variety.

Abroad.

Hamburg, 7.45, Concert of operetta excerpts and waltz songs.

THURSDAY, DECEMBER 31st.

Nat., 7.15, Van Phillips and his Two Orchestras. 11, "New Year's Eve."

Reg., 6, Medvedeff's Balalaika Orchestra. 8.15 "Cinderella."

Abroad.

Most Continental Stations are giving special New Year's Eve programmes from 7, onwards.



Cosso photo.

the small hours of 1937. The German stations commence with the 6 o'clock relay of Dr. Goebbels' New Year's address to the nation from Berlin. Many of them give a purely local programme, with dialect sketches and relays of folk music and general jubilation.

Perhaps the most notable of these commences at 7.10 from Leipzig where the district chosen is that round the Sudetic Alps. The Munich programme timed for 9 includes a relay of the fun in a ski-ing hut at Bayrischzell, in the Bavarian Alps.

Stuttgart, Frankfurt and Saarbrücken will provide a joint programme of entertainment from 7 p.m. until 1 a.m. entitled "We join hands at the happy end of the year."

"A year passes by in a thousand joyous notes" is the title of the 9-11 programme from Deutschlandsender, which is a musical retrospect of 1936. At 11, which is midnight in Germany, Intendant Goetz Otto Stoffregen, Germany's most popular station director, will address listeners after which, under the title "Hinein" (In we go), three light orchestras will provide entertainment until 2 a.m. on January 1st.

AN ANCIENT ORGAN

THE famous historic organ of the ancient Danish Royal Castle, Frederiksborg, in North Sealand, will be heard at 5 o'clock on Christmas afternoon from Copenhagen-Kalundborg. Jens Laumann will play this organ, which is thought to be the oldest of its kind in North Europe.

THE AUDITOR.

Letters to the Editor

The Editor does not hold himself responsible for the opinions of his correspondents

Hill and Dale

PERMIT me to correct your correspondent S. R. Eade, "Sound Recording" (December 4th, 1936), in regard to his statement referring to Edison phonographs. These instruments were marketed up to 1926, and in their improved form were known as the Edison Diamond Disc Reproducer, employing disc records, 10in. diameter, with screw reproducer traverse, and each record with a playing duration of from 3 to 5½ minutes. A 12in. record was also available, which had a playing duration of no fewer than 20 minutes. The records were built up with cement centres and coated with a hard celluloid finish, and were practically indestructible. The diaphragm in the reproducer was built up from a number of sheets of Japanese tissue paper, and was mounted on a cork ring. The horn in my own instrument was 6ft. in length, and was exponential in shape, giving remarkably good quality of reproduction. As a matter of fact, the first moving-coil loud speakers of those days were, in my opinion, greatly inferior to the Edison Diamond Disc phonograph.

G. MCAULEY.

Belfast.

I WOULD like to correct a statement of Mr. S. R. Eade in his article on sound recording in *The Wireless World* of December 4th.

The paragraph I refer to concerns the Edison phonograph, and the statement that the hill-and-dale method was discarded for various reasons, due to the difficulty of building the mechanical apparatus with sufficient precision, is incorrect.

The Thomas Edison phonograph, which was popular in the early days of recording, was a finer example of precision engineering than any popular motor to-day.

To prove my point, the machine in mind had two tracking pitches, 100 to 200 per inch, and, as the record was replayed with the lead screw in mesh, precision was the main point in manufacture.

I fully appreciate one point, however. No phonograph manufactured in England reached the quality of performance available in the genuine Thomas Edison machine, which sold, incidentally, for £4 10s.

If any of your readers care to play Edison records of thirty years ago, using a suitable pick-up and amplifier, I think they will be agreeably surprised at the quality possible with this type of record.

London, N.8. C. D. PICKERSGILL.

I HAVE been very interested to read the remarks of your two correspondents, Mr. Pickersgill and Mr. McAuley, concerning the Edison Phonograph. I must admit that I was not aware that a "hill and dale" type reproducer of this make had been marketed as late as 1926.

In the statement to which these two gentlemen take exception I was not intending to criticise the mechanics of the cylinder or disc drive. I pointed out that, in my opinion, the difficulty of building the "pick up" or "sound box" portion of the

mechanism to work by mechanico-acoustical means did not allow full use to be made of the inherent advantages of the "hill and dale" system. The electrical reproducer (usually of moving-coil form) alone made this possible.

If your correspondents can suggest any other reason for the universal adoption of the transverse track on gramophone records I will be very interested to read their comments.

S. R. EADE.

Rugby.

Rejecting Whistles

MR. P. K. TURNER'S position in attempting to saddle me with responsibility for his inability to understand my heterodyne filter is logically untenable, and therefore I decline to bear even a part of the responsibility as he suggests.

The crucial point is that he claims to have put the system into operation and to have made it work. The exact nature of the claim is not clear, but there seem to be three possibilities: Either he set up (a) the system described in his article, (b) the system described in my article, or (c) some other system altogether. Let us take these possibilities in reverse order.

(c) Would in no way be connected with the matter, and we can dismiss it at once. If the claim is (b), it carries with it the admission that my article is sufficiently clear to allow of constructing and operating the system successfully, so that it cannot be too bad; it is certainly not my fault if Mr. Turner uses my circuit in his experiments and another one in his description of them. In case of (a) it is obvious from the reasoning in my last letter that the system described by Mr. Turner under the title of "Baggally's Retroactive Filter" cannot possibly work, so that if it were true that he claims to have made it work it would also be true that his results were so wildly in error as to cast the gravest possible doubts on his powers of observation in general. Under those circumstances it would not be surprising, and I should not be to blame, if he failed to observe and understand the points of my article.

Brighton.

W. BAGGALLY.

Wavelength Allocation

YOUR timely leading article on wavelength allocation will give all serious students of broadcasting ample food for thought.

The time has come when the World's Broadcasting Authorities must face the obvious problem—is high-quality transmission worth while without radical alteration in wavelength allocation?

So far as I am aware, no receiver to-day can do full justice to the best of modern transmission, except under exceptionally favourable conditions.

We must either sacrifice the higher frequencies or endure sideband splash.

Undoubtedly, the best compromise at the present is the Monodial variable selectivity superheterodyne, for which we have to thank the pioneering work of the *Wireless World*.

Attention has been called to an old method of avoiding interference, viz., the frame aerial, by "Cathode Ray" and others, the great drawbacks being inefficiency and local disturbances.

Both of these could, I believe, be overcome by a large frame, for which ample room exists in the lofts of most dwelling-houses. This would have to be set and tuned once and for all for the broadcasting station which gives at the receiver the greatest entertainment value. Other stations would be received on a separate aerial.

Screening by earthed, fine-meshed wire netting might be necessary to prevent pick-up from stations approximately to 180 deg. from the wanted transmission.

Connection between such a frame and the receiver does present serious problems.

In these days of coaxial feeders and matching transformers, however, the problems should not be insoluble.

Many readers would, no doubt, be very grateful for suggestions of practicable methods of carrying out this suggestion.

J. KING.

Sutton, Surrey.

The Hartley Turner "Duode"

WHILE we much appreciate the kindly reference to our "Duode" loud speaker in your issue of December 4th, we should like to supplement your description of the voice-coil.

You state that "the speech coil is wound on a light aluminium former . . ." etc.

Actually, the speech coil is wound on a bakelite former, and the centring washer is also attached to this former. The cone is attached to the aluminium tube, a thin tube of synthetic rubber fitted over the aluminium tube, and then the whole inserted into the speech coil former.

Thus the force on the cone is derived in part from currents induced into the aluminium tube as you describe, and in part from the currents in the speech coil; the latter force acts through the compliance of the rubber tube.

It is the balance between these two forces as frequency varies that gives the improved response.

We might also mention that improvements in manufacture since your sample was supplied have much decreased the tendency towards "belling," or "noding" as we call it, at certain low frequencies.

In justice to others, we should also like to make it clear that we make this voice-coil under licence from Messrs. Benjamin Electric, Ltd., who first introduced the principle.

HARTLEY TURNER RADIO, Ltd.

Isleworth.

Television Programmes

I CANNOT agree with your view that it is any business of the B.B.C. to popularise television. As a result of such popularising, the B.B.C. would hardly be expected to gain sufficient in licence fees to pay the extra expenses, and the real beneficiaries would be the television promoters and set builders and retailers. *Ergo*, if the B.B.C. provides the means of demonstration, surely the onus to provide the "matter" should be on those interested, and no blame can be thrown on the B.B.C., which should not act as an advertising medium.

Broadstone.

G. F. FLEMMICH.

The Pentode Tone Corrector

THERE was one thing left over from my last article ("Pentodes and Loud Speakers") that seemed to call for special attention. It is the resistance and capacity generally connected across any loud speaker driven by a pentode. When I say loud speaker I include its transformer. A tone-correction circuit *could* be connected across the secondary of the transformer, and hence across the loud speaker speech coil itself; but that would necessitate an excessively large capacity.

Another reason for connecting across the primary is that it then also helps to correct the imperfection of the transformer.

The object in wanting a tone-correction circuit at all was explained in the previous article. Briefly, it is that a pentode works according to plan only when the load (loud speaker) which it drives is of constant impedance, and preferably a pure resistance. Any inductive admixture inevitably causes the impedance to vary with frequency, with undesirable effects on the quality of reproduction. In a good loud speaker and transformer the inductance is probably not very large, but even so is hardly negligible. Pentode tone in the raw is seldom mild; it is usually strident.

The obvious thing to do to soften it down a bit is to shunt a condenser across it. Now everybody (here) knows that an inductance and a capacity together form a tuned circuit, which responds most strongly to a particular frequency. At least, that is so if the resistance in the circuit is not altogether excessive. The result is painfully marked when a high-inductance speaker is "corrected" by a simple condenser, because the combination tunes to

HOW TO ARRIVE AT THE CORRECT CHOICE OF COMPONENTS

beyond a certain point, a circuit fails to "tune." It does not seem to be very generally known that under certain conditions a circuit with inductance and resistance in one branch and capacity and resistance in the other is as a whole equivalent to a *resistance* which is *constant at all frequencies*. This is exactly what one wants for a pentode to work into, as by making this equivalent resistance equal to "optimum" the valve works under the best conditions all the time. The requirements for this desirable state of affairs are not very complicated. If R is the AC resistance of the speaker and L its inductance, the proper corrector circuit consists of a capacity numerically equal to $\frac{L}{R^2}$ (the units being farads and henrys) in series with a resistance R. The whole behaves at all frequencies as a resistance R, which there-

By "CATHODE RAY"

power that reaches the speaker. Whether that matters or not depends on how strongly one wants to hear such frequencies, and how efficient the speaker is in reproducing them. If the loss begins to be noticeable only when the frequency is at the top of the desired audible range it is all to the good. Generally that means a moderate inductance.

Another thing, if the inductance is too high an excessive proportion of the watts delivered by the valve will be wasted in the condenser-resistance branch.

The extent of such loss can be judged by calculating the frequency at which the inductance of the speaker and the capacity of the corrector would resonate if the resistances did not intervene. That can be done by means of one of *The Wireless World* "Abacs," or the well-known formula

$$f = \frac{1}{2\pi\sqrt{LC}}$$

By the way, unless otherwise stated, in these formulæ L is always in henrys and C in farads. At the frequency thus calculated the loud speaker and the corrector divide the valve's output equally between them. At lower frequencies the speaker gets the bigger share; at higher frequencies the corrector absorbs more than the speaker. Obviously if the dividing line occurs low in the scale—say at a few hundred cycles per second—the proportion wasted is excessive and the efficiency is low.

The familiar tone corrector circuit (a) is equivalent electrically to (b), where L and R are the inductance and resistance of the loud speaker and its transformer. When C and R are correctly chosen, this in turn is equivalent to R, from the valve's standpoint, and the circuit can be represented by (c).

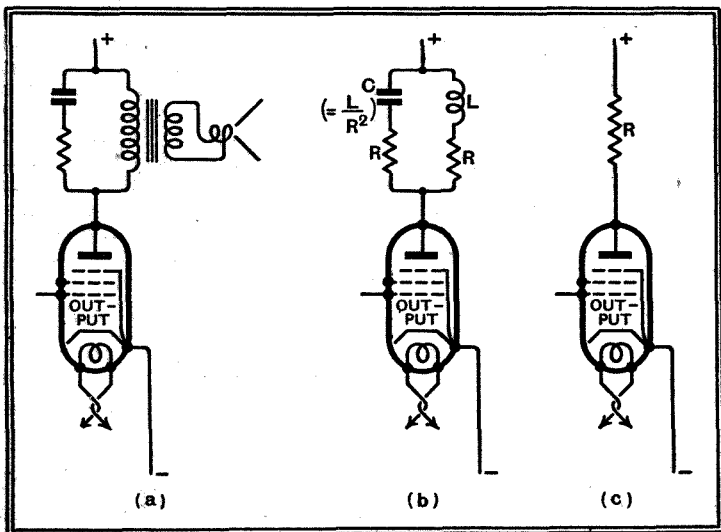

fore is the "optimum resistance."

While this system prevents the valve load from varying, however large the inductance may be, it is still desirable to keep it as small as

a note probably somewhere in the middle of the audible scale, and that note is emphasised above all the rest. "Fain would I change that note," as the song says, and as the listener is likely to think after a short while.

However, if the resistance is increased

possible for several reasons. One is that although the circuit as a whole presents a constant impedance to the valve at all frequencies, that branch containing the loud speaker does not; and, if the inductive part of its impedance predominates at any frequency, there is a falling off in the

Practical Approximations

Up to the present we have been taking some things rather much for granted. In practice the resistance R of a speaker is not by any means absolutely fixed; nor, for the matter of that, is L, because certain effects, such as transformer capacity and shunt inductance, complicate the matter. But the general idea holds good, and the result of using a corrector is certainly much nearer the ideal than doing without it.

Another thing taken for granted is that R and L are known. Actually it is extremely unlikely that they are. Manufacturers give some idea of R, as a rule—they have to in order to enable the speaker to be matched to the valve—but are obviously not likely to emphasise L. And it is difficult to measure it without a laboratory bridge. In the accompanying table are given the results of some measurements I made on a few speakers that happened to be about the place. They were made at a frequency of 3,200 c/s.—high, because otherwise the error

The Pentode Tone Corrector—

due to the shunting effect of the transformer primary inductance would be large. Except for the last one (which would not be used with a pentode), and, of course, the two in parallel, the capacity is in each case not very far off 0.004 mfd.

Bearing in mind the very approximate nature of all calculations concerning loud speakers, this choice—or, at any rate, the nearest common value, 0.005 mfd.—seems likely to be about right in most cases. The correct resistance to connect in series with it is, of course, easily found, as it is the same as the "optimum load resistance," and the same as the speaker ought to be.

To check results, the effect was tested of actually connecting a condenser of approximately 0.0041 mfd. in series with 9,900 ohms across the primary of the transformer under the conditions referred to in the third line of the table. The impedance of the whole arrangement was then found to be 9,600—a reasonably good approximation to 9,900—and was very nearly a pure resistance. If it were not for the corrector circuit the impedance at the same frequency would be 12,700 ohms, rising rapidly at higher frequencies. At 800 c/s, with corrector, the impedance was 8,800 ohms.

It often happens that an extension loud speaker is plugged in. This upsets the matching of valve to loud speaker in any case, unless there is some elaborate system for changing the transformer ratio. To keep the inductance balanced out it is necessary to increase the corrector capacity; and it is interesting to note that, although neither R nor L conforms to simple theory by falling to a half when there are two speech coils in parallel in the example given, yet the capacity is just about double, as it ought to be. If it is not thought worth while embodying arrangements for altering the transformer ratio when one or more extra speakers are in use, a scheme for increasing the capacity of the condenser is unlikely to be considered; but in such cases it is a good plan to make the capacity rather greater than would be needed for one speaker only. This is generally done; 0.01 mfd. is a usual value in manufactured sets. In any case a some-

what over-corrected system is usually favoured, more especially as there is a tendency for loud speaker effective resistance to rise with frequency.

Quite a common arrangement is a variable resistance instead of a fixed one, usually accompanied by an abnormally large capacity. This is dignified by the

name of variable tone control. It is true that with it one can vary the tone, to the extent of cutting down the "top" (and incidentally lowering the general volume at the same time); but it upsets a well-matched system and ideally it is better to have a fixed tone corrector and to do the variable tone controlling somewhere else.

RANDOM RADIATIONS

By "DIALLIST"

A Merry Christmas

A MERRY Christmas to you all, and may you have no wireless worries this week-end! I suppose that there's no season of the year when the wireless set is more used than Christmastide. Luckily, it's about the best time of the whole year for hearing foreign stations, since the field strength of distant transmitters is at its best and atmospheric conditions are usually few and far between. Thousands of new sets will be put through their paces for the first time. Yet greater numbers of receivers that are old and tried friends will be used to explore Europe, or, maybe, the world in general. And I've no doubt that countless fathers will be told by their families that the job of the set at Christmas time is not to go flitting hither and thither, like a bee amidst the flowers, but to settle down to one station and provide something jolly in the way of entertainment. This is rather hard on poor father, particularly as he will have provided the set; but there it is. Queer noises from America or Australia won't be half as popular as the, to some ears, queerer noises of dance bands from stations nearer home.

Christmas Listening

If you want cheery programmes from abroad at Christmas you're most likely to find them in the Teutonic and Scandinavian countries. They celebrate Christmas thoroughly, but the Latin countries reserve most of their energies for New Year's Eve. You'll be well advised, therefore, if the family isn't satisfied with the home programmes, to concentrate on Norway, Sweden, Germany, Denmark, and Holland in order to obtain programmes with the real Yuletide flavour. A look through the foreign programmes will show you that there's plenty of choice amongst the stations that you can count on receiving well. Carols, folk-music, orchestral concerts, Christmas

revels and operas are there for a twist of the tuning knob. And when the family is amusing itself in other ways, as no doubt it will, there'll be plenty of opportunities for letting the new or the old set show what it can do in the way of bringing in stations from here, there and everywhere.

Radiophonographs

MY best thanks to two kind readers who have written to tell me the word used in the United States for what we call a radiogram. It appears that it is either "Combination Radio" or "Radiophonograph." I'm rather surprised, I must say, that Americans, whose language is renowned for the brevity, crispness and neatness of its terms, can't do better than this. One possible reason is that hitherto the radiogram has not been very widely seen in the States; hence the need for a really good name for it may not have been felt. I hear that these instruments are now making big headway, largely because there is so much advertising "ballyhoo" in the broadcast programmes. Another interesting sign of the times is that many American sets are being provided with pick-up terminals this year, though previously these were seldom seen. Americans, in a word, are returning to the gramophone record and realising that electrical reproduction is the only way of bringing out all that is on a modern record.

A Dream and Nothing More

A READER writes to ask me for a circuit diagram of the dream set whose make-up I outlined in these notes a while ago. He particularly wants details of the oscillator amplifier and so forth. I'm afraid I can't oblige, for the dream set must remain a dream, for the present, anyhow. To build it would need months of experimental work and cost goodness alone knows what. And no circuit diagram would be of very much value unless it were taken from a set that had been made up and found to work as it should. Nor is it at all certain that my dream set wouldn't be other people's nightmare! One of the peculiarities of dyed-in-the-wool radio enthusiasts is that they can never see or hear a set made by anyone else without at once beginning to devise methods of improving it. I recommend, therefore, that each and everyone in search of a diversion for spare moments should evolve in imagination his own ideal set. It may never assume concrete form—more than probably it won't—but that does not matter a bit. Castles are out of fashion nowadays, but there's a vast amount of pleasure to be derived from building wireless sets in the air.

Shades of Marconi!

IT'S rather surprising to learn that in Italy there is virtually no interest at all in wireless construction as a hobby. Every-

Type of Speaker.	Type of Transformer.	R in Ohms.	L in Henrys.	Calculated C in Microfarads.	Critical Frequency f in c/s.
Commercial energised model. 8in. cone, lin. coil of 2½ ohms.	Usual small commercial type. No DC in primary.	15,600	0.92	0.0038	2,700
Ditto	Ditto: 25 mA in primary	14,300	0.84	0.0041	2,720
Commercial perm. mag. model. 7in. cone, lin. coil of 15 ohms.	Good-quality type (Ferranti ratio 25:1). No DC in primary.	9,900	0.4	0.0041	3,950
Ditto	Ditto: 22 mA in primary	9,700	0.4	0.0043	3,850
Ditto: two in parallel ...	Ditto: no DC	5,800	0.31	0.0091	3,150
Dual perm. mag. speakers for high quality.	Special dual type ...	2,200	0.046	0.0095	7,600

Random Radiations—

thing has been done by the authorities to encourage broadcasting on both the medium and the short waves, and few European countries are better served as regards either the stations themselves or the programmes that they transmit. Further, Italians, as a nation, are both mechanically and electrically minded; they are excellent engineers, and they have "electrified" their country rapidly and extensively. They were amongst the first to develop the transmission of power at high voltages over lengthy cable lines. And one *does* seem to have heard the name Marconi. These things being so, one would have thought that Italians, in the towns and cities anyhow, would have taken to wireless experimenting as ducks take to water. But it isn't so. A reader living for the time being in Italy tells me that obtaining any kind of component—even such a simple thing as a resistor—is a grim business. You try dealer after dealer without success, and, when you do discover one who is willing to order what you want (you won't find it in stock), you're lucky if you get it in less than a month.

Some Service!

AN American contemporary, *Radio News*, is engaged in investigating the shady side of radio service work in New York, and very shady some of it seems to be. A particularly straightforward five-valve set was first of all given a thorough test in the laboratory to ensure that every part, including valves, was in tip-top working order. Each component was then marked so that it could be identified. One of the speech-coil leads to the loud speaker was unsoldered at the output transformer end, the set was installed in a private flat, and service concerns (unaware, of course, with whom they were dealing) were summoned one after another to locate and rectify the fault. The first man who came spotted it at once, set matters right, and made a moderate charge. The lead was again unsoldered and No. 2 came to try his hand. He diagnosed a broken-down condenser, quoted 4 dollars (16s.) for the job, and was allowed to take the set away. It was returned three days later in working order, with the assurance that a condenser had been replaced. Examination showed that the original condensers and no others were still in the set. No. 3 took the set away and a report was telephoned to the effect that a coupling condenser had broken down and the output transformer burnt out. Cost of job, 28s. Again no renewals whatever were made.

Curiouser and Curiouser

On the fourth occasion the set was left with a service company, which reported a defective speech-coil. They charged 10s. and again put in no new part. Like the others they did nothing but resolder the lead that was adrift—except that they removed a brand new valve and inserted an old one in its place. The fifth concern took refuge once more in the broken-down condenser diagnosis, and gave an estimate of £1. As the set wasn't ready at the end of 9 days, it was taken away, and it was found that the service (!) people had never even undone the packing in which it was delivered.

Well, I think that our service work is a bit better than that. I've come across several cases of inefficiency, but never, so far, one of deliberate swindling by charging for the replacement of parts that were not replaced. The worst in our land of the service man who doesn't know his job is that

he may have a set that won't work returned quite unnecessarily to the makers, thus landing you into the costs of carriage, both ways as well as those of the work. Service work in this country is improving notably, and much credit is due to the larger manufacturers, especially the E.M.I. Service, Ltd., for educating the dealer and making him look upon service in a proper business-like spirit.

Service Insurance

SOME time ago I suggested that it would pay retailers to work out service and maintenance schemes, whereby the purchaser of a set could put down a fixed sum of so much a week, a month or a quarter for regular inspection and complete maintenance of his apparatus, with full service and including every necessary renewal of parts and valves. A good many firms now have such arrangements, and I am glad to see that the movement is spreading. After all, it shouldn't be too difficult to work out a figure that is fair to the set owner and will pay the dealer, so long as the latter remembers that he is likely to be dealing with scores, and possibly hundreds, of people, and not just with one isolated case. The dealer must have been in business for a good few years now, and he should have a pretty shrewd idea of what the average set owner spends on repairs and renewals. With that as a working basis he can arrive at a figure that should be satisfactory to all concerned. If he does start an "insured maintenance" scheme on a sound footing, I'm sure he'll find it a paying business, for this kind of thing may well turn the casual customer into a permanent one.

Aerials Again

A LONDON reader raises an interesting and important point with regard to outdoor aerials. "Many of us," he writes, "who are sufficiently interested in wireless to read *The Wireless World*, are also interested in modern houses, decoration, furniture and gardening, and we will not have any of the present outdoor aerial systems at any price for what we consider good aesthetic reasons. To add a forest of poles and wires to a residential district is obviously anti-social and, in the long run, inimical to all radio interests."

THE RADIO INDUSTRY

NEW leaflets issued by Marconi-Ekco Instruments, Ltd., describe a Distortion Factor Meter for measuring total harmonic content and a Beat Frequency Oscillator covering the range 10-10,000 c/s.

Many new productions are described in the latest edition of the Eddystone catalogue of short-wave components, issued by Stratton and Co., Ltd., Bromsgrove Street, Birmingham, 5. Prices of certain components have been reduced.

The G.E.C. has received an order from the Crown Agents for the Colonies for a radio relay equipment to be installed on the Gold Coast.

Change of address: Harries Thermionics, Ltd., to Britannia House, 233, Shaftesbury Avenue, London, W.C.2. Telephone: Temple Bar 8327.

A statement from the London office of the *Foire de Paris* (17, Tothill Street, S.W.1) lays emphasis on the international character of the Fair and the greater opportunities that it now offers to British manufacturers.

MCCARTHY
for the finest value in
All-Wave Receivers!

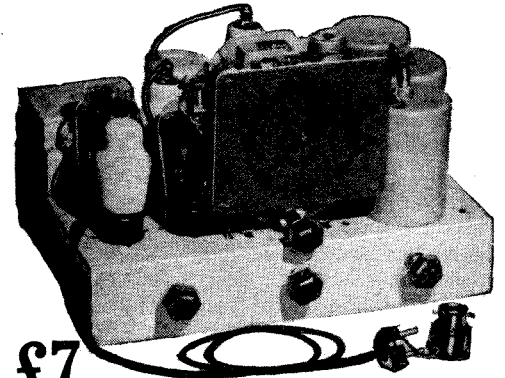

£7
6 VALVE ALL-WAVE SUPERHETERODYNE
(complete with B.V.A. Valves)

Improved edition of this popular receiver (praised "Wireless World" test reports). Heavier gauge cadmium-plated steel chassis. Iron-cored I.F. transformers give even better performance. No increase in price.
Brief Specification: 8-stage, all-wave band-pass superheterodyne, 7 tuned circuits. D.A.V.C. with "squelch" circuit valve for noise suppression. Illuminated "Airplane" dial. Octode frequency changer. 3-5 watts pentode. Switching for gramophone pick-up. Wave ranges: 16.5-50, 200-550, 800-2,000 metres.

"De Luxe" Model
MCCARTHY ALL-WAVE SIX

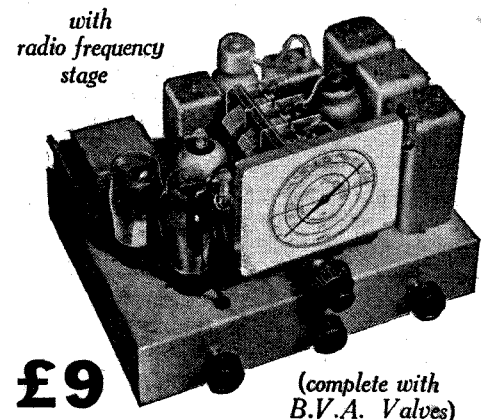

"De luxe" 6 valve receiver with 8 valve performance (specially recommended for tropical and foreign reception conditions). Built on special cadmium-plated 16 gauge steel chassis. Varley iron-cored I.F. coils. Litz-wound tuning coils, 3 wave-ranges—16.5-2000 metres. Illuminated "Airplane" dial with principal station names. Micro-vernier 2-speed drive.
Circuit comprises: Pre-selector radio frequency amplifier (operative on all wavebands), triode-hexode frequency changer, double band-pass coupled I.F. amplifier, double diode-triode detector. D.A.V.C. applied to 3 preceding valves. I.F. amplifier and pentode output. Variable tone control and volume control operate on radio and gramophone.

All McCarthy receivers supplied complete with valves, knobs, pilot lamps, leads, mains cable and plug. 12 months' guarantee.
Deferred terms on application, or through London Radio Supply Co., 11, Oat Lane, E.C.2.
Cash with order on 7 days' approval. Also write for illustrated catalogue of complete range of all McCarthy receivers.

MCCARTHY RADIO LTD.
44a, Westbourne Grove, London, W.2
Telephone: Bayswater 3201/2.

Resistance-Coupled Amplifiers

PART VI.—THE GRID BIAS CIRCUIT

THE details already given cover the more important points in the design of resistance-coupled amplifiers, but in the case of mains-driven equipment the bias circuit will well repay attention. It is the usual practice to employ cathode biasing wherever possible, for this makes each valve independent of the others and some degree of automatic compensation for variations in the characteristics of different specimens of valves of the same type is obtained.

When cathode biasing is used grid circuit decoupling serves no useful purpose in a resistance-coupled amplifier. Referring to Fig. 15, AC potentials are set up across the bias resistance R_5 in the cathode circuit of V_2 , and these must be prevented from reaching the grid of this same valve. Accordingly, R_4 and C_4 are often interposed in the grid return lead to act as a decoupling circuit, the idea being that as the voltage applied through R_2 to the grid is that de-

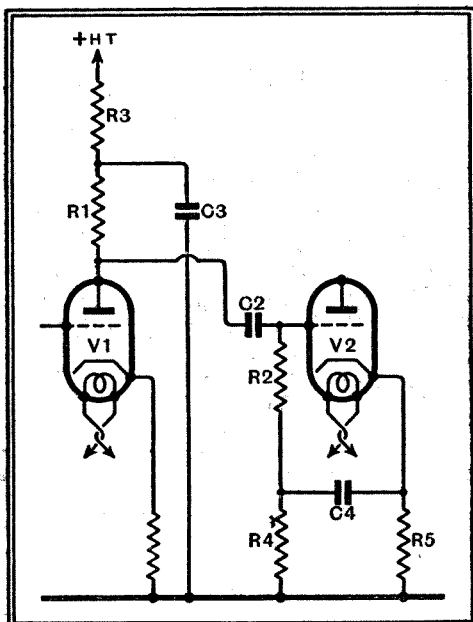

Fig. 15.—As explained in the text, grid-circuit decoupling is ineffective with resistance-capacity coupling.

veloped across C_4 it will be negligible if the reactance of C_4 at the lowest important frequency is very small compared with the resistance of R_4 . This is quite true, but, unfortunately, there is an alternative path by which voltages developed across R_5 can reach the grid—this path being through C_3 , R_1 and R_2 —and the decoupling circuit is consequently of no practical utility. Where the circuit is such that this alternative path does not exist, as may sometimes happen in the case of the coupling from a diode detector, then it is quite satisfactory to employ decoupling.

The Bias Resistance and Feed-Back

Because of these facts, it is the general practice to employ the circuit of Fig. 16, which is the same as Fig. 14 of Part V, in which a condenser C_4 is connected across the bias resistance R_4 . If the reactance

of the condenser is very small at the lowest frequency compared with the resistance of R_4 , then the voltage developed across the combination, and

*I*N this concluding article of the series, automatic grid bias and anode circuit decoupling are treated. The bias circuit can cause a loss of amplification or frequency-distortion if it is not properly arranged and in certain circumstances the

decoupling condenser can lead to a rising bass characteristic.

hence the feed-back to the grid circuit, will be negligible. If we assume that the reactances of C_2 and C_3 are negligible compared with their associated resistances, the effect of any impedance in the cathode circuit is easily dealt with and the amplification of the stage becomes

$$A = g r \times \frac{\sqrt{1 + 1/\omega^2 C_4^2 R_4^2}}{\sqrt{1 + \left\{1 + \frac{R_4(1+\mu)}{R+R_a}\right\}^2 / \omega^2 C_4^2 R_4^2}}$$

where $R = R_1 R_2 / (R_1 + R_2)$.

It is easy to see that the amplification tends to fall off at low frequencies. It must not be forgotten that the loss introduced by this circuit is that found with perfect transmission by the intervalve coupling proper, and that if the coupling causes a loss of bass the action of the bias circuit may be somewhat modified. This is not very important, however.

First of all, let us suppose that we use no condenser C_4 at all. The amplification then becomes

$$A = g r \times \frac{R + R_a}{R + R_a + R_4(1 + \mu)}$$

There is no frequency distortion, for the gain is reduced equally at all frequencies. The amount of reduction is best realised from a typical case, and taking the amplifier stage considered earlier, we have $R = 22,750$ ohms, $R_a = 10,000$ ohms, $R_4 = 1,000$ ohms, and $\mu = 20$. Consequently $A = 0.61$ gr. The amplification is

only 61 per cent. of that obtained with perfect by-passing.

If a by-pass condenser is used which is not large enough, the resistance will be adequately by-passed only at high frequencies, and the full gain will be realised only at those frequencies. At low frequencies feed-back will occur and reduce the amplification. In the particular case cited above, the maximum loss of bass which can occur is 4.36 db. If we decide that the loss at the lowest frequency required can be 1 db., then the necessary value of C_4 can be calculated from

$$C_4 = \frac{\sqrt{\left[1 + \frac{R_4(1+\mu)}{R+R_a}\right]^2 - 1.26}}{3.2 f R_4}$$

Inserting the values given above and taking the lowest frequency as 20 c/s, we find $C_4 = 18.65 \mu\text{F.}$ The nearest standard value is $25 \mu\text{F.}$, and this would give a loss of rather less than 1 db. at this frequency. In the case of an output valve, such as the PX4, the by-pass capacity should be $67.5 \mu\text{F.}$, assuming a resistive load.

The Bias Resistance

To obtain such large capacities at reasonable cost and with reasonable dimensions, it is, of course, necessary to use electrolytic condensers, and these are now readily obtainable. It is important to note that if for any reason it is impossible to use a large enough condenser, it is better to dispense with it entirely. Only the gain will then suffer, not the frequency response. Difficulty in obtaining adequate by-passing rarely occurs with triodes, but is common with tetrodes and pentodes.

Before concluding this section a useful

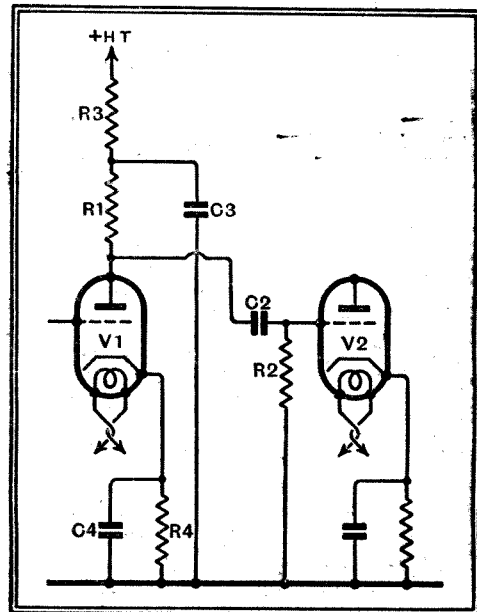

Fig. 16.—The reactance of the decoupling condenser C_3 can, under suitable conditions, cause a rise in the bass response.

Resistance-Coupled Amplifiers—

rule for the choice of the bias resistance is worth noting. Although it can only be accurately determined by the methods described in Part V, it so happens that with triodes the optimum value is roughly equal to the load resistance divided by the amplification factor of the valve, or $R_4 = R/\mu$. Also, roughly, the capacity of C_4 in microfarads is equal to 19,000 divided by R_4 , for a loss of 1 db. at 20 c/s.

The amount of anode circuit decoupling which is needed is not a matter which can readily be settled on theoretical considerations, for it depends upon the amount of amplification following the stage under consideration and upon the impedance of the HT supply. The larger the values of the resistance R_3 and condenser C_3 , the greater the decoupling efficiency. The ratio of the voltage applied to the grid of V_2 (Fig. 16) to a voltage in the HT supply is given by

Ratio of voltages =

$$\frac{R_a}{R_a + R_1} \times \frac{I}{\sqrt{I + I/\omega^2 C_2^2 R_2^2}} \times \frac{1}{\sqrt{\omega^2 C_3^2 R_3^2 + \left(1 + \frac{R_3}{R_a + R_1}\right)^2}}$$

It can be seen that making R_1 higher than R_a tends to improve the decoupling, as also does a small value of $C_2 R_2$. The value of $C_2 R_2$ is fixed by the bass response required, however, and so cannot be varied to reduce feed-back effects without adversely affecting the frequency response. The decoupling proper is governed by the third factor in the above equation, and it will be seen that it depends chiefly upon the product $C_3 R_3$. It is clear, however, that while an increase in the value of either C_3 or R_3 will increase the decoupling, the use of a larger value of R_3 will have a greater effect than a similar increase in C_3 . In other words, for a given product $C_3 R_3$, greater decoupling is secured with a high value of resistance and small condenser than with a low resistance and large capacity. This effect is only present to any marked degree when R_3 is of the same order as, or greater than, $R_a + R_1$.

Decoupling

In general, it is convenient and inexpensive to use 8 μ F. electrolytic condensers for decoupling in LF circuits, and to vary the value of the various decoupling resistances to obtain the requisite decoupling. In the case of the penultimate stage, experience shows that a decoupling resistance of the order of 10,000 ohms provides adequate decoupling and does not drop the anode voltage excessively. Much more decoupling is needed in the preceding stage, however, and with the same value condenser something like 50,000 ohms is usually required. Fortunately, it is quite possible to employ such a value without reducing the anode voltage excessively, for the undistorted output required is much smaller than in a later stage, and the valve can safely be operated at a comparatively low voltage.

Before leaving the decoupling circuit it may be mentioned that under suitable conditions it is capable of giving a rising characteristic in the bass! If the reactance of C_3 is comparable to the resistance of R_1 at low frequencies, but is yet low compared to the resistance of R_3 , the load impedance will rise at low frequencies and hence the amplification. When R_3 is very large it is possible so to choose the values of R_1 and C_3 that the loss in R_2 and C_2 is compensated exactly. In general, the effect is not marked with triodes, but when screen-grid or pentode valves are employed it is quite easy to secure a rising bass characteristic. The effect is most marked when, in addition to the conditions mentioned above, R_1 is less than R_a .

Earlier instalments of this series describing the characteristics and design of resistance-coupled amplifiers were included in the following issues:—

- Part I.—The Fundamental Operating Conditions, Oct. 30th.
- „ II.—The Coupling Condenser and Grid Leak, Nov. 6th.
- „ III.—Calculating the Performance, Nov. 13th.
- „ IV.—Valve Capacities, Nov. 27th.
- „ V.—Valve Operating Conditions., Dec. 18th.

Club News

The Exeter and District Wireless Society

Some very interesting lectures have recently been given to members of the above society including one on the di-pole aerial by Mr. F. Thorn, who very ably demonstrated the difference between this and the ordinary receiving aerial. A lantern lecture given by Mr. Marne, M.I.E.E., on "Electronics and Cathode-Ray Tubes" proved very popular. After explaining the methods of making these devices the lecturer dealt with their use, more especially in the case of the cathode-ray tubes which television has brought so much to the fore. Meetings of the society are held at 3, Dix's Field, Exeter, on Mondays, at 8 p.m., and those interested are invited to get into touch with Mr. W. J. Ching, 9, Sivell Place, Exeter.

The Golders Green and Hendon Radio Scientific Society

The most satisfactory method of receiving the sound accompaniment to the B.B.C. television programmes is engaging the attention of most real enthusiasts at the present, and a lecture on this subject by Mr. D. N. Corfield, D.L.C., proved extremely interesting. The lecturer pointed out that, owing to a better signal-to-noise ratio, an anode bend detector was preferable to a diode. A triode hexode seemed to be the best frequency-changer, said the lecturer, who also strongly advised a stage of signal-frequency amplification, and the provision of a separate control for the oscillator circuit. Full details of the society can be obtained from the Hon. Secretary, at 60, Pattinson Road, Hendon, N.W.2.

The Croydon Radio Society

The special loud-speaker night held recently, at which members were invited to bring their instruments for comparative tests, proved an extremely popular feature. Members decided that no one loud speaker could be adjudged superior to the others on all counts. A lecture by Mr. H. G. Menage on piezo-crystals proved very instructive. Great interest was aroused by a new piezo-electric pick-up working on the torsion principle. The members of the society ask us to convey their best wishes for Christmas to readers and invite those interested in their activities to communicate with Mr. E. L. Cumbers, 14, Campden Road, S. Croydon.

POINTS OF IMPORTANCE
in the Rola
G.12

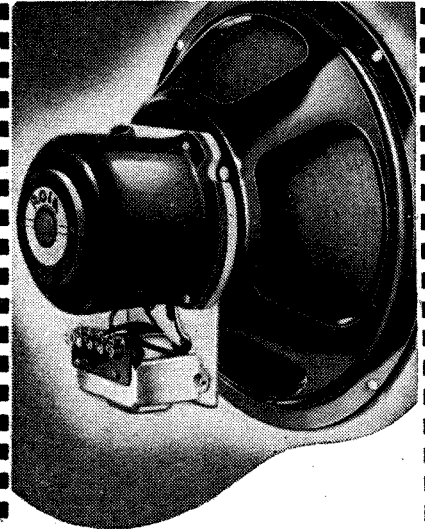

GILT-EDGED SECURITY

A scrap of paper like many another scrap of paper . . . but a Gilt-Edged Security because of the name it bears. So with the Rola G.12. It is a speaker that is not only famous itself for true high fidelity reproduction, but which, because of its remarkably high quality, guarantees the whole set in which it is found. Manufacturers who mean their sets to be built throughout to the highest possible standards of perfection choose the G.12, and the fact that in many cases production on models using G.12's has had to be increased shows that the public endorses their choice. Whether you are a manufacturer or a listener, take the earliest opportunity of hearing a G.12.

- G.12 D.C. (as illustrated) Stripped, but with Transformer . . . £4 4 0
 - G.12 D.C. Complete with Transformer, Mounting Stand, Handle and Base . . . £5 5 0
 - G.12 D.C. with Mounting Stand, Handle and Base, but without Transformer . . . £4 16 0
 - G.12 D.C. Stripped and without Transformer . . . £3 15 0
- (When ordering please state Field Resistance and Impedance of Transformer required.)
- G.12 P.M. less Transformer . . . £4 16 0
 - G.12 P.M. with Transformer . . . £5 5 0

For Public Address work both the P.M. and Energised Models can be supplied with a 15 ohm Voice Coil at an additional charge of 3/-.

Write for Folder A.

OVER 7 MILLION IN USE

ROLA

The World's Finest Reproducers

THE BRITISH ROLA CO., LTD.
MINERVA ROAD, PARK ROYAL, N.W.10.
PHONE: WILLESDEN 4322-3-4-5-6.

Brief descriptions of the more interesting radio devices and improvements issued as patents will be included in this section.

Recent Inventions

SIGNALLING SYSTEMS

IN short-wave signalling valves are used which are constructed with a closed "resonator" space between the electrodes. This is stated to avoid "leakage" radiation, and to increase efficiency both in transmission and reception.

Because of the higher level of energy available, a large number of intermediate frequencies can be superposed on a single short-wave carrier, thus allowing greater scope than usual for multiplex working.

Also the intermediate-frequency signals can be graduated in strength, so that certain of the transmitted signals can be received on a simple and comparatively cheap type of receiver, whilst other broadcast items are only available to a more limited circle of subscribers possessing more sensitive and expensive sets.

N. V. Machinerieen En Apparaten Fabrieken "Meaf." Convention date (Germany) October 27th, 1934. No. 453733.

SOUND AND PICTURE RECEIVERS

THE dipole aerial A receives sound and picture signals radiated on ultra-short-waves, both sets of signals being fed through an amplifier V, where they are separated. The picture signals are fed through a further ampli-

The amplifier V is a superhet. circuit, the separation of the sound and picture signals being effected by a series-tuned circuit in one of the IF stages.

A. C. Cossor, Ltd., L. H. Bedford, and O. S. Puckle. Application date March 7th, 1935. No. 453484.

MOTOR CAR RADIO

THE screening action of the metal roof of a motor car has forced designers to look for a more suitable place in which to locate the aerial. Somewhere underneath the chassis is a possible alternative, though it brings the aerial closer to the local interference from the ignition, and therefore necessitates expensive screening.

According to the invention a folded dipole aerial is used, made of a U-shaped rod or tube, and of such dimensions that it is broadly resonant to a frequency of about 7 metres, which is usually the wavelength of the interference radiated from the ignition system. Owing to the standing-wave formation set up, such interference is neutralised in the aerial itself and will not be fed into the receiver, if the latter is connected at points equidistant from the free ends of the U-shaped dipole. The lead-in to the receiver consists of a screened transmission line, which serves as a fixed filter against interference and, in combination with the tuned input circuit, presents a band-pass characteristic to the desired signals.

Marconi's Wireless Telegraph Co., Ltd. (assignees of R. M. Smith). Convention date (U.S.A.) December 29th, 1934, and May 31st, 1935. No. 453736.

The valve V1 is, in effect, a "floating" modulator, since the rectified grid-bias varies in accordance with the instantaneous value of the applied signals. The power taken by the valve V1 is accordingly regulated by the changing levels of modulation input,

According to the invention, the rapid-acting switch is located in the grid circuit of one of the low-frequency amplifiers, and is operated through a branch circuit which is coupled to one of the high-frequency stages. This branch circuit includes an amplifier and a rectifier. When an abnormally strong impulse is received, the branch circuit passes a corresponding pulse of rectified current, which "opens" the grid circuit of the LF amplifier and so cuts out the loud speaker. Since the switch is

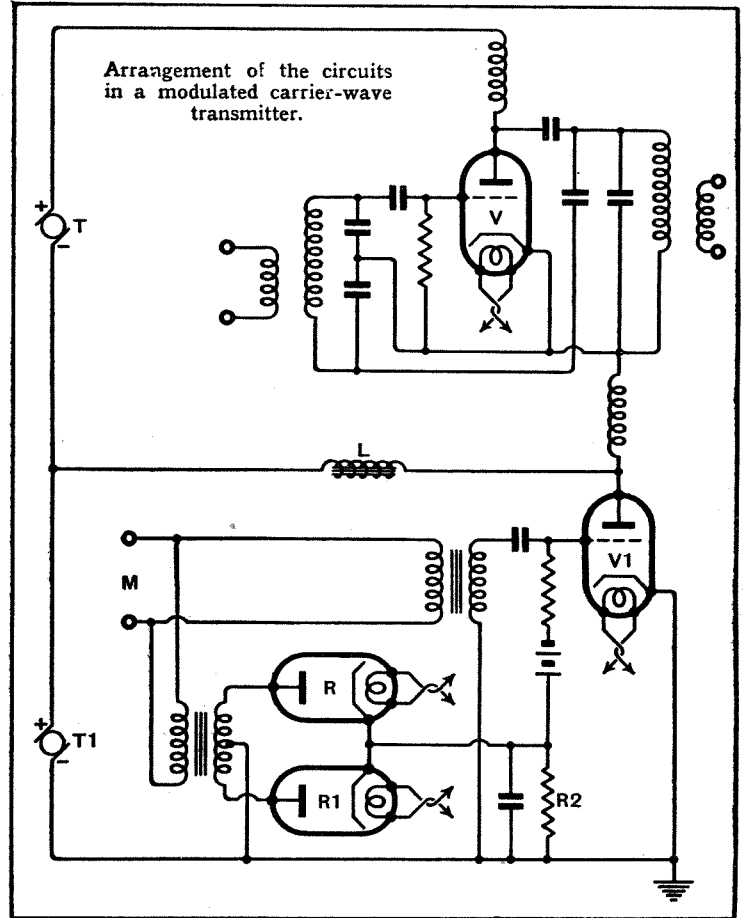

although the mean amplitude of the carrier-wave output developed by the valve B remains substantially constant.

Marconi's Wireless Telegraph Co., Ltd., and W. T. Ditcham. Application date March 11th, 1935. No. 453501.

SUPPRESSING STATIC

THE invention relates to the type of static-suppressor in which the interfering impulse is made to open a rapid-acting switch, or to otherwise break a part of the receiving circuit, so that both the disturbance and the signal are momentarily cut out. Since the duration of a static impulse is usually very brief, the break is so short that the apparent continuity of the signal is not affected, although the interfering impulse is completely suppressed.

placed at a point in the receiver at which no direct current or voltages are present, the "break" does not give rise to any "click" or similar undesirable noise in the loud speaker.

N. V. Philips Gloeilampenfabrieken. Convention date (Germany) April 13th, 1935. No. 453261.

TELEVISION RECEIVERS

IN place of an ordinary lamp, a cathode-ray tube is used to produce X-rays, the intensity of which is then controlled by the incoming television signals. The resulting X-rays after passing through a scanning disc are projected on to a large fluorescent screen for viewing.

D. Applebaum. No. 2048094 (U.S.A.).

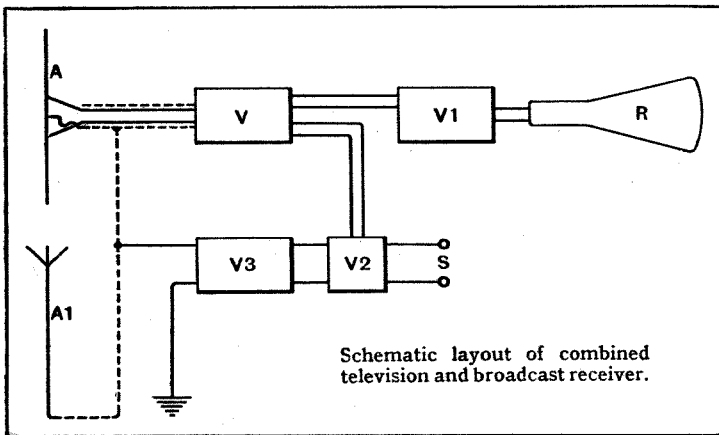

Schematic layout of combined television and broadcast receiver.

fyng stage V1 to a cathode-ray reproducer R, while the audible signals pass through a low-frequency amplifier V2 to the loud speaker S.

For receiving medium- or long-wave broadcast programmes the dipole aerial A is earthed by a down-lead, which is coupled as indicated in dotted lines to a separate input amplifier V3. Alternatively, a second aerial A1 may be used for normal broadcast working, either alone or in combination with the dipole A.

MODULATING CIRCUITS

A CARRIER-WAVE amplifier V is arranged, in series with a modulating-valve V1, across a divided source of high-tension T, T1, and a low-frequency choke L is inserted across the junction between the two valves and the two HT sources. Modulating signals are applied to the grid of the Valve V1 from M, part of the signal voltage being passed through a full-wave rectifier R, R1 so as to develop a grid-bias across the load resistance R2.

The British abstracts published here are prepared, with the permission of the Controller of H.M. Stationery Office, from Specifications obtainable at the Patent Office, 25, Southampton Buildings, London, W.C.2, price 1/- each. A selection of patents issued in U.S.A. is also included.